



***Multi-Axis Force/Torque Sensor***  
F/T

## Product Description

The Force/Torque (F/T) sensor system measures the full six components of force and torque (Fx, Fy, Fz, Tx, Ty, Tz) using a monolithic instrumented transducer. The F/T transducer uses silicon strain gages for excellent noise immunity. The use of silicon gages allows the F/T transducer to have high stiffness and increased overload protection. All transducer models are available with Net F/T, DAQ F/T, or Controller F/T interfaces.

The Net F/T provides EtherNet/IP™, DeviceNet, and CAN bus communication interfaces and is compatible with standard Ethernet. Additional fieldbus interfaces, such as PROFINET, are available as an option.

The DAQ F/T connects the transducer to your computer bus (PCI, USB, PC Card, etc.) using an analog Data Acquisition (DAQ) card, making it easy to read sensor data with your PC or robot controller. ATI DAQ software works with your computer to convert strain gage data into force/torque data.

The Controller F/T processes the F/T strain gage information, outputs serial and analog force/torque data, and provides discrete I/O.

The Wireless F/T is a small wireless transmitter for up to six ATI Multi-Axis Force/Torque transducers. It uses the 802.11b/g/n wireless standard at 2.4 GHz or 5.0 GHz.

## Product Advantages

**Overload Protection:** The F/T transducer is extremely rugged and durable. The transducer's factor-of-safety can be as high as forty times, depending on model and calibration.

**High Signal-to-Noise Ratio:** Silicon gages provide a signal 75 times stronger than conventional foil gages. This signal is amplified resulting in near-zero noise distortion.

**High-Speed Output:** F/T systems are available with updated rates as high as 28.5kHz. This speed exceeds requirements of most robotic and data collection applications.

**Tool Transformations:** Tool transformations can be used to translate and rotate the F/T point-of-origin to make measurements relative to the work at hand.

**Versatile Outputs:** PCI, PCI Express, voltage, USB, PXI, discrete I/O, Ethernet, various industrial fieldbuses, and more are available.

**Temperature Compensation:** Each F/T transducer features hardware temperature compensation to stabilize its sensitivity over temperature. This compensation method optimizes the transducer's accuracy over a range approximately  $\pm 25^\circ \text{C}$  from room temperature.

**Robot Compatibility:** F/T systems are compatible with equipment from a variety of robot manufacturers. Contact ATI for more information.



Multi-Axis Force/Torque Transducers

## Table of Contents

- Quick-View Specification Table . . . . . 3
- DAQ F/T System . . . . . 4-5
- Net F/T . . . . . 6-7
- Wireless F/T System . . . . . 8-9
- Controller F/T System . . . . . 10
- How To Select an F/T Transducer . . . . . 11
- Options . . . . . 11
- Nano17Ti (Titanium Nano17) . . . . . 12
- Nano17 . . . . . 14
- Nano25 . . . . . 16
- Nano43 . . . . . 18
- Mini40 . . . . . 20
- Mini45 . . . . . 22
- Mini58 . . . . . 24
- Mini85 . . . . . 26
- Gamma . . . . . 28
- Delta . . . . . 30
- Theta . . . . . 32
- Omega85 . . . . . 34
- Omega160 . . . . . 36
- Omega191 . . . . . 38
- Omega250 . . . . . 40
- Omega331 . . . . . 42

“When Lear Corporation partnered with KUKA Robotics to develop the OccubotVI seat testing system, we envisioned a robot that allowed for simultaneous load and position control. The critical component to achieving true load control was a sensor that could interface in real time with the robot kernel and receive commands directly while maintaining full robustness and accuracy necessary to duplicate exact human loading with sufficient repeatability. ATI Industrial Automation was the only choice, not just for the Theta transducer, which handily met all our demands, but primarily because of the excellent support from their technical and sales staff. Their partnership in the project was a key factor in its success.”

Terry O’Bannon,  
Sr. Engineer, Biomechanics and Robotics  
Lear Technologies, LLC

## Quick-View Specification Table

Sensing ranges listed below are the maximum along the axis, other calibrated ranges are available.

Description	Nano17Ti	Nano17	Nano25	Nano43	Mini40	Mini45	Mini58	Mini85
Rated Fxy ±lb (±N)	7.2 (32)	12 (50)	50 (250)	8 (36)	20 (80)	120 (580)	600 (2800)	420 (1900)
Rated Txy ±lbf-in (±Nm)	1.6 (0.5)	4 (0.5)	50 (6)	4 (0.5)	40 (4)	160 (20)	1000 (120)	740 (80)
Weight* lb (kg)	0.0223 (0.0101)	0.02 (0.00907)	0.14 (0.0634)	.0854 (0.0387)	0.11 (0.0499)	0.202 (0.0917)	1.1 (0.499)	1.4 (0.635)
Diameter* in (mm)	0.669 (17)	0.669 (17)	0.984 (25)	1.69 (43)	1.57 (40)	1.77 (45)	2.28 (58)	3.35 (85.1)
Height* in (mm)	0.571 (14.5)	0.571 (14.5)	0.85 (21.6)	0.454 (11.5)	0.482 (12.2)	0.618 (15.7)	1.18 (30)	1.17 (29.8)

Description	Gamma	Delta	Theta	Omega85	Omega160	Omega191	Omega250	Omega331
Rated Fxy ±lb (±N)	30 (130)	150 (660)	600 (2500)	420 (1900)	600 (2500)	1600 (7200)	3600 (16000)	9000 (40000)
Rated Txy ±lbf-in (±Nm)	100 (10)	600 (60)	3600 (400)	740 (80)	3600 (400)	12000 (1400)	18000 (2000)	52000 (6000)
Weight* lb (kg)	0.562 (0.255)	2.01 (0.913)	11.0 (4.99)	1.45 (0.658)	6.0 (2.72)	20.8 (9.41)	70.0 (31.8)	104 (47.0)
Diameter* in (mm)	2.97 (75.4)	3.72 (94.5)	6.1 (155)	3.35 (85.1)	6.16 (156.5)	7.48 (190)	11.6 (295)	13.0 (330)
Height* in (mm)	1.31 (33.3)	1.31 (33.3)	2.41 (61.1)	1.32 (33.4)	2.2 (55.9)	2.52 (64.0)	3.74 (94.9)	4.22 (107)

\*Specifications include standard interface plates.

## Configurations

DAQ F/T Systems come in one of two configurations depending on the size of the transducer.

**Internal Interface Board Configuration:** Transducer with internal interface board electronics (Gamma and larger), transducer cable, power supply box, power supply cable, data acquisition board, and user computer.

**External Interface Board Configuration:** Transducer without electronics (Nano and Mini Series), interface power supply box, power supply cable, data acquisition board, and user computer.

## Components

**Transducer:** The transducer senses applied loading with six degrees of freedom (Fx, Fy, Fz, Tx, Ty, and Tz). Gamma and larger transducer models have the interface board inside the transducer while Nano and Mini transducer models require the interface board to be housed in an interface power supply box (IFPS). ATI software must be used to convert the transducer's uncalibrated output to calibrated values.

**Transducer Cable:** For our Nano and Mini transducer models, the transducer cable is integral to the transducer. For other transducers the transducer cable is attached with a connector. The transducer cable is a long-life flexible cable specially designed for noise immunity. This durable cable protects the transducer signals from electrical fields and mechanical stress.

**Interface Board:** The interface board electronics receive transducer gage signals and converts them to readable DAQ card signals using noise immunity technology. Each interface board is calibrated to mate to a specific transducer. The interface board is mounted within the Gamma and larger transducer models and is located in the interface power supply box (IFPS or IFPSMC) for the Nano and Mini transducer models. Since transducer output is uncalibrated, ATI software must be used to produce calibrated output.

**Power Supply:** The power supply converts power from the data acquisition card or from an external power supply to regulated power used by the transducer. The power supply is mounted in a small box that connects to the transducer cable on one end and to the data acquisition card on the other. When not mounted on the transducer, the interface board is mated directly to the power supply.

**Power Supply Cable:** The power supply cable conducts 5 volt power to the power supply box or interface power supply box and transmits the transducer signals to the data acquisition card. The cable is a flexible long-life design with special noise immunity features.

**Data Acquisition (DAQ) Card:** The data acquisition card plugs into your PC, receives the analog transducer signals via the power supply cable and (with ATI software on your computer) converts them into data to be used by computer programs. Our data acquisition cards are available in a wide variety of configurations and supply power to the F/T system. In some cases, you can use an existing data acquisition system.

### DAQ Multiple Transducer IFPSMC Box (optional):

This version of our standard Interface Power Supply Box provides power and signal amplification/conditioning for up to six transducers. It connects to an 80-channel DAQ card using standard off-the-shelf cables. The IFPSMC is available only for transducers that do not have internal interface board electronics.

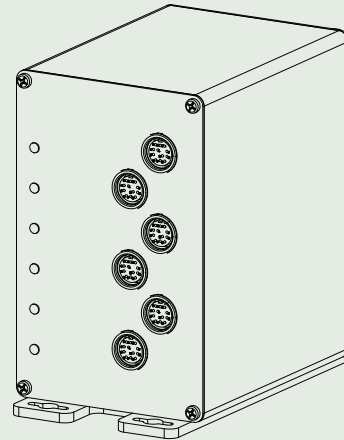

Multiple Transducer IFPSMC Box

**DAQ F/T Dual Gain (optional):** A transducer may have two calibrations which allow switching between higher resolution calibration and a larger-range calibration. The larger-range calibration must be exactly twice the higher-resolution calibration. Switching calibrations is as easy as just loading the other calibration.

#### Note:

ATI DAQ systems perform best when used with the cabling and data acquisition hardware we supply. The demanding nature of precision analog signals makes it likely that other configurations will not perform optimally. The use of breakout boxes, unshielded cables, and wires that are not twisted pair is discouraged as their use will result in increased noise.

## DAQ Cards

Our DAQ F/T System works with DAQ cards we specify or with differentially-ended or single-ended analog inputs on your DAQ hardware; however, differentially-ended inputs are preferred for the best noise immunity.

**Note:**

The DAQ F/T outputs amplified, conditioned strain gage signals to a data acquisition card—not the resolved force and torque data. ATI software (included) running on the host computer performs computations to convert the strain gage voltage data into force/torque data. You must acquire all six strain gage channels in order to calculate any of the forces and torques.

**ATI Supports the Following Bus-Types:**

- PCI
- PCI Express
- PXI
- USB

Contact ATI regarding other bus-types. Most bus-types are available in 16-bit resolution.

**Note:**

Most laptop computers and PC Card (PCMCIA) peripherals do not have provisions for proper signal grounding. External grounding may be necessary to reduce some of the resulting additional noise.

## DAQ Software

ATI provides DAQ F/T software components that you can use to build your application, as well as a sample application program. The software components include an ActiveX server, a C library and a .NET Assembly described below.

**Software Component Features**

The .NET Assembly ATICombinedDAQFT is a Windows .NET Assembly that performs the core operations of the DAQ F/T system, including:

- loading calibration files.
- configuring the transducer system, including tool transformations.
- reading and converting transducer signals from NI-DAQmx-compatible DAQ systems into forces and torques.

ATICombinedDAQFT can be used in any development environment that supports .NET. For non-Windows operating systems, and DAQ cards not supported by NI-DAQmx, ATI provides a C library and ActiveX Server which performs system configurations, and calculates F/T values from voltages read from your DAQ system.

**Application Program**

The Windows DAQ F/T application program displays graphical and numerical force and torque output for Windows™ operating systems. Visual Studio 2003 source code is provided as an aid in creating additional application programs. This program only works with NI-DAQmx-compatible boards.

## DAQ F/T System

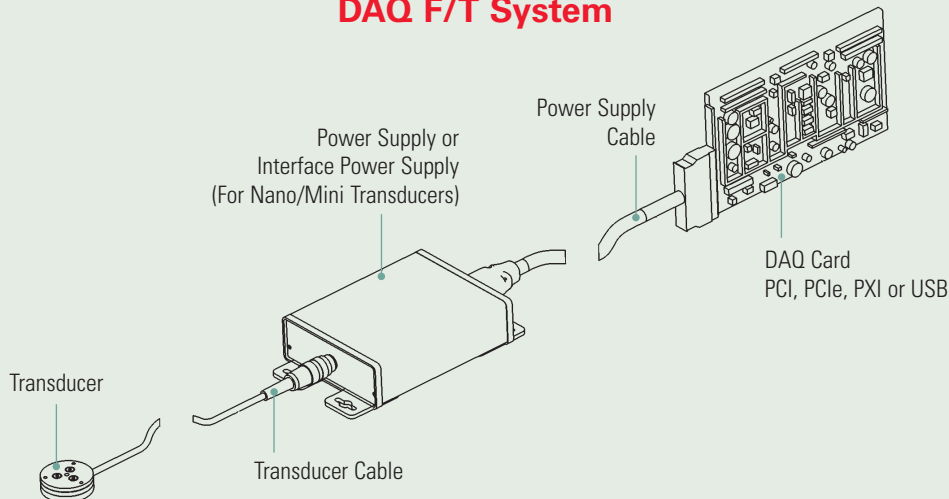

## Net F/T

The Network Force/Torque (Net F/T) sensor system measures six components of force and torque (Fx, Fy, Fz, Tx, Ty, Tz). The Net F/T provides an Ethernet and a CAN bus communication interface and is compatible with standard Ethernet protocols, EtherNet/IP™, and DeviceNet™. The Net F/T system is available with all of ATI's transducer models.

## Product Features

- Fully ODVA™-compliant EtherNet/IP interface.
- Environmental sealing is available. The Net F/T interface (Net Box) is sealed to IP65 (water splash-proof), most Net F/T transducers and cables can be sealed to IP68 (submergibility in fresh water to a depth of 10 meters).
- Powered by Power-over-Ethernet (PoE) or by an external power supply (11VDC to 24VDC).
- Multiple transducer calibrations can be permanently stored in the system and can be selected by the user.

## Product Advantages

**Multiple Interfaces:** Ethernet, EtherNet/IP, DeviceNet, and CAN bus, to support a wide range of automation and research applications. A PROFINET interface is available as an option. Other industrial fieldbus options are being developed by ATI.

**LAN Connectivity:** The Net F/T can be easily connected to your Local Area Network (LAN) allowing for easy remote operation and monitoring.

**High-Speed Output:** Output rates up to 7000 Hz for six axes of measurement over Ethernet (using UDP).

**Web-Based Configuration and Demo:** The Net F/T is configurable via a web interface, allowing the user to view and change system settings using a web browser. An easily accessible Java™ demonstration application provides a graphical view of six-axis measurements in real time.

**Programmable Thresholding:** Allows monitoring of force and torque conditions via a relay output or status bits to allow immediate action in case of critical process conditions.

**Built-In Status Indicators:** LEDs in the Net Box alert the user to connection and load saturation status.

**Tool Transformations:** Tool transformations can be used to translate and rotate the F/T point-of-origin to make measurements relative to the work at hand.

**Programmable Low-Pass Filters:** When enabled, the transducer data is passed through low-pass filters with user-selected cut-off frequencies.

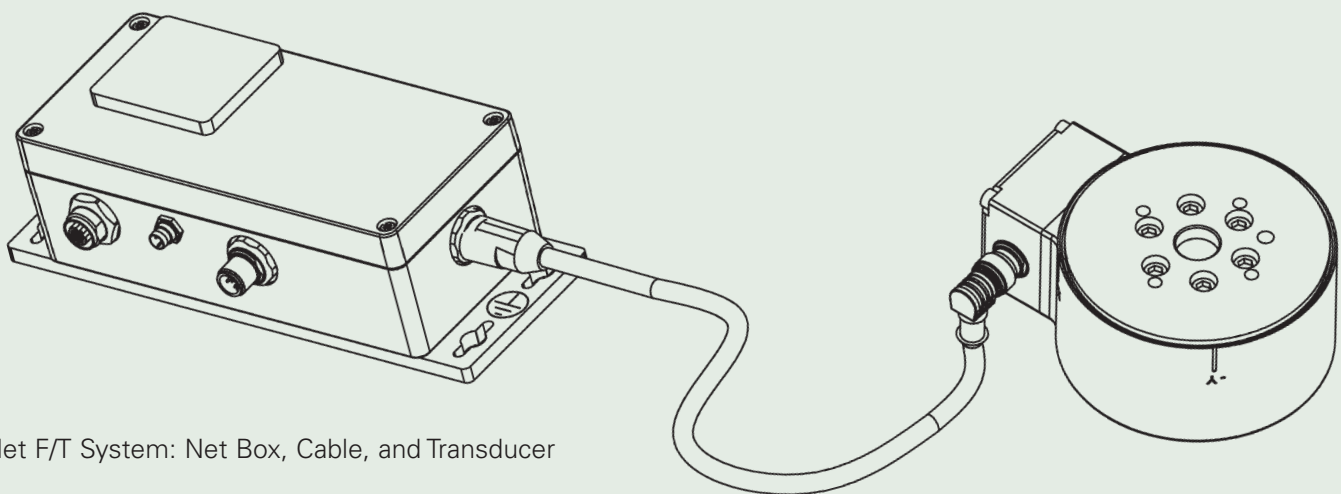

Net F/T System: Net Box, Cable, and Transducer

## User Interface Overview

Sensor system setup and status monitoring can be done through the status LEDs and DIP switches or via an Internet browser. Advanced functions and the demonstration application are also available via a browser.

### Indicator Window Functions

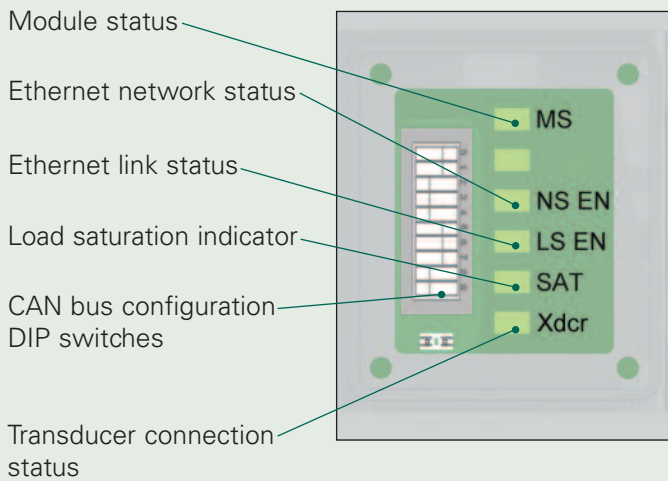

### User I/O

DIP switch and status indicator window

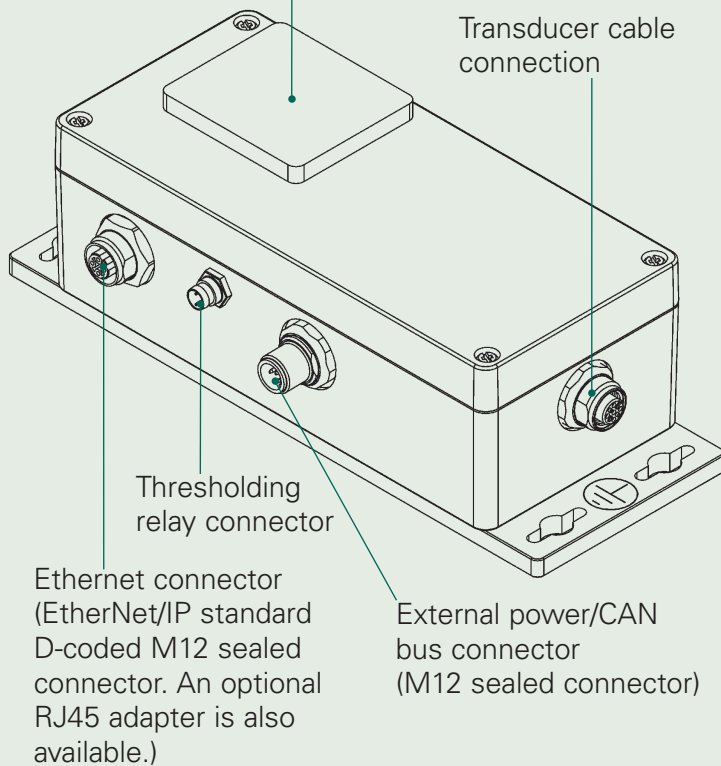

### Easily-Accessible Configuration Settings



### Self-Contained Demonstration Application

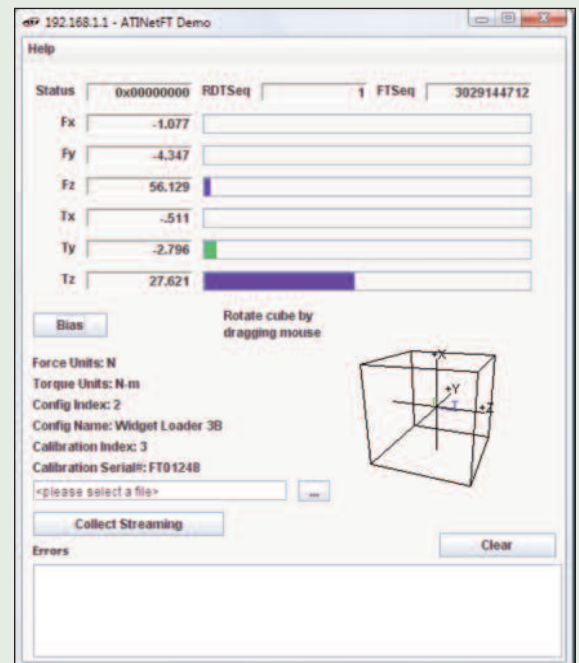

## Wireless F/T

The Wireless F/T is a pocket-sized wireless transmitter for up to six ATI Multi-Axis Force/Torque transducers. The Wireless F/T can stream to the user's host device for data collection, real-time motion control, or user-defined signal processing. The Wireless F/T comes in two configurations, one that supports up to six transducers and one that supports up to three transducers.

## Product Features

- Communicates using IEEE 802.11 a/b/g/n at either 2.4 GHz or 5.0 GHz, so it can easily be used with an existing wireless infrastructure.
- Supports as many as six ATI transducers simultaneously.
- Typical range is 30 m (98 ft), in an office type environment. With unobstructed environments a 100 m (328 ft) range is possible.
- Small enclosure with robust mounting features:  
Three Transducer Wireless F/T: 150 mm × 82 mm × 19 mm (5.9 in. × 3.2 in. × 0.75 in.), excluding mating connectors.  
Six Transducer Wireless F/T: 150 mm × 82 mm × 33 mm (5.9 in. × 3.2 in. × 1.3 in.), excluding mating connectors.
- Battery life is approximately one hour at full measurement rate with six transducers enabled, and is extended significantly when using fewer transducers. External power may be used.
- Includes a Java demo program and source code.

## Additional Capabilities

- **Multiple Power Options:** Uses a removable, rechargeable battery that can be charged internally or externally. The Wireless F/T can be powered from the Micro USB connector, using an external, high-current, 5VDC power supply.

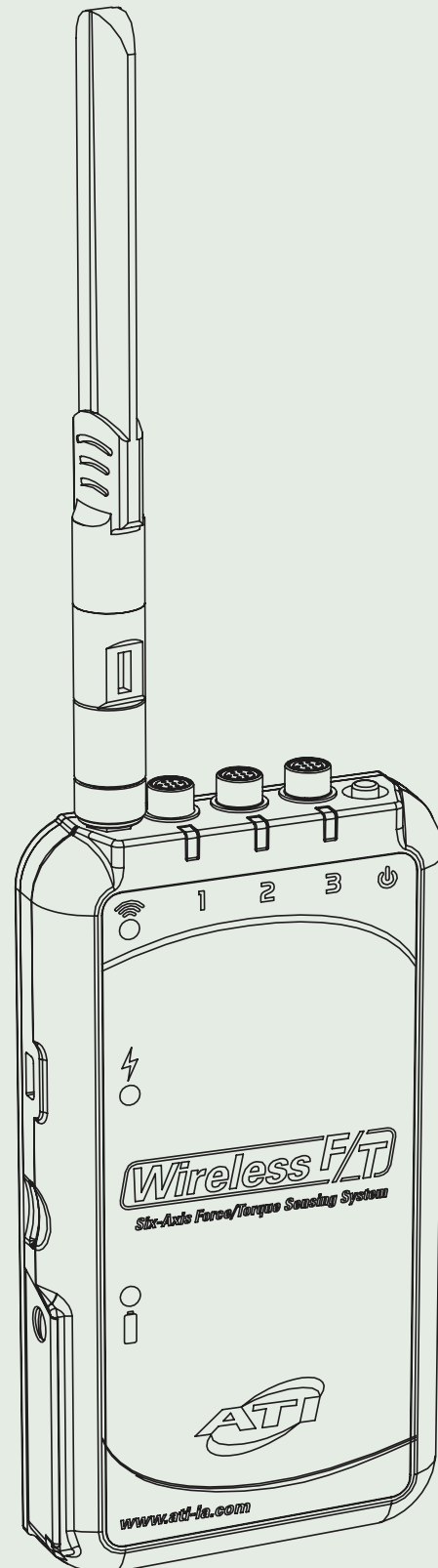

Three-Transducer Wireless F/T Unit



## Wireless F/T Interface

### Using a Computer with Wi-Fi Direct™

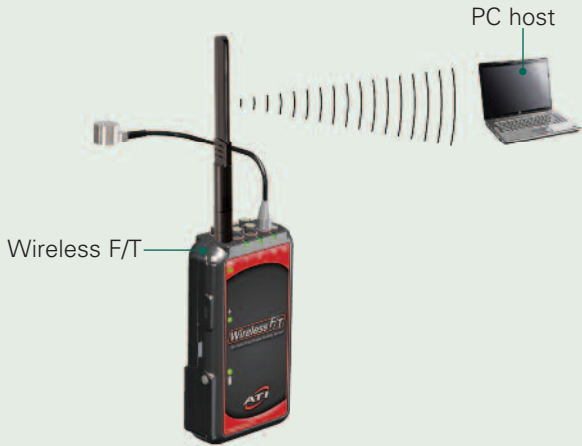

### Using a Wireless Access Point



Six-Transducer Wireless F/T Unit

# CONTROLLER F/T SYSTEM

## Configurations

The Controller F/T system comes in one of two configurations depending on the size of the transducer.

**Internal Mux Board Configuration:** Transducer with internal mux board electronics (Gamma and larger, except Omega85), transducer cable, and controller.

**External Mux Board Configuration:** Transducer without electronics (Nano and Mini, and Omega85), mux box, mux cable, and controller. Omega85 transducers also require a transducer cable.

## Components

**Transducer:** The transducer senses forces and torques applied in six degrees of freedom (Fx, Fy, Fz, Tx, Ty, and Tz). Except for Omega85, Gamma and larger models have on-board electronics (known as the mux board) while Nano, Mini, and Omega85 models require these electronics to be in a separate housing (known as the mux box).

**Transducer Cable:** For our smaller transducers (Nano and Mini Series) the transducer cable is integral to the transducer. For other transducers, the cable is attached to the transducer with a connector. This durable, long-life, flexible cable protects the transducer signals from electrical fields and can withstand mechanical stress.

**Mux Board:** The mux board electronics connect directly to the transducer's sensing elements and provide high-level output signals. Each board is calibrated to work with a specific transducer. The board is mounted in the transducer when possible. When not possible, as in the Nano, Mini, and Omega85 transducers, the board is located in the mux box.

**Mux Cable:** Systems with a mux box will also require a mux cable. The mux cable is a highly-flexible, long-life cable. This durable cable protects the transducer's signals from electrical fields and mechanical stress.

**Controller:** The controller interfaces with the transducer to process the transducer data into usable force and torque data and to provide high-level functions like tool-transformations and threshold detection. It is powered by standard AC power. The controller communicates over an RS-232 serial port and can also output loads via analog voltages. Its optically isolated discrete I/O port connects easily into many industrial applications to respond to user-programmed threshold conditions.

## Controller F/T System

**Note:**

A Mux box is added between the transducer and controller for Nano and Mini models.

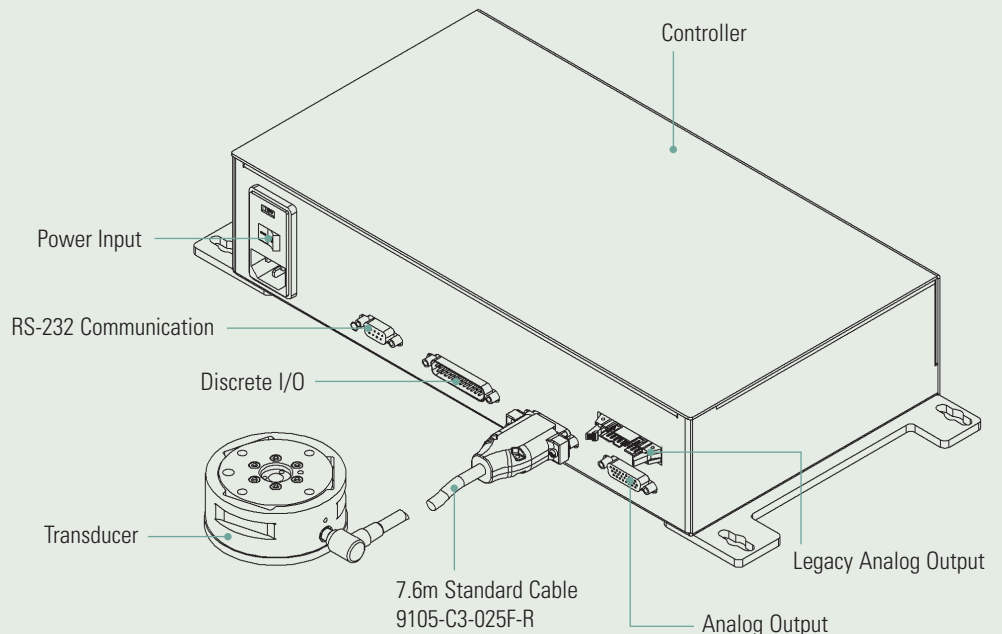

## How to Select an F/T Transducer

### 1. Calculate Expected Moment and Forces

Moment capacity is usually the determining factor in choosing the best transducer model for your application. The end-effector attached to the transducer, as well as the tasks being performed, will generate forces on the transducer, which will result in a moment. The moment is the applied force (dynamic and static together) multiplied by the distance from the transducer origin to the point at which the force is applied. It is important to also consider overload conditions beyond the normal operating forces and moments the transducer will experience.

### 2. Identify Transducer Strength

Use the Quick-Selection Guide on page 3 to compare the measuring ranges of the transducer models available.

### 3. Verify Resolution

The required resolution should be considered. A fine resolution requirement can conflict with a transducer chosen based on moment capacity. Transducers with larger ranges have coarser resolutions.

### 4. Inspect Other Transducer Specifications

Compare the detailed specifications of the chosen transducer to those of your application requirements to be certain the chosen transducer is appropriate for your application.

### Example:

The expected maximum measured load is 98 N (10 kg) of force and the end-effector is 25 cm long. The moment generated would be 24.5 Nm.

The best F/T would be a Delta/SI-330-30 (330 N, 30 Nm) which can handle the 24.5 Nm moment. The maximum single-axis moment rating (T<sub>xy</sub>) of this model is 280 Nm, which should be sufficient for overload situations.

### Note:

The published payloads of robots are typically the maximum load the robot can handle at published positional resolution. The robot can actually handle much larger loads, but with some loss of positional repeatability. During a crash, both inertia and the sudden deceleration can generate large loads. Robots are typically overpowered for an application, and the robot is capable of exerting forces many times its rated load.

You may decide to select a transducer with a lower payload with the understanding that this will increase the chances of damaging the transducer during a crash.

## Options

While our standard systems provide all the necessary components for measuring force and torque, we also have available options which may aid in interfacing the F/T sensor system with special applications.

**Interface Plates:** All F/T transducers come with standard interface plates. Some models have threaded hole patterns machined into both sides that are used for attaching to the customer's equipment. Others have a threaded hole pattern on the tool side and a blank plate on the mounting side. The blank plate is machined by the customer to accommodate specific mounting requirements. For exact specifications for the various transducer models, refer to the product drawings in this catalog.

**Custom Interface:** ATI can help you design and fabricate interface plates needed for a nominal price. Please contact an ATI salesperson for additional information.

**Multiple Calibrations:** With this option, one transducer can have more than one calibration. The Net F/T and DAQ systems allow calibrations to be selected via software, while the Controller F/T uses a switch and software control. This allows the use of one calibration for a low payload with high resolution, and the other calibration for a larger payload with a lower resolution.

**Environmental Protection:** Several models of transducers are available with IP60, IP65, and IP68 protection. An IP60 version is for use in dusty environments. The IP65 version of the transducer provides protection against water spray. The IP68 version is for underwater environments to a maximum depth of 4 or 10 meters in fresh water (see individual model pages for depth specifications). Contact ATI Industrial Automation for drawings and more information.

# NANO17Ti (TITANIUM NANO 17)

## Product Advantages

### Our Smallest 6-Axis Sensor Now Available in a Titanium Version:

The Nano17Ti fits into restricted spaces of research applications and is non-ferrous.

### Extremely High Strength:

- EDM wire-cut from grade 5 titanium.
- Maximum allowable single-axis overload values are 4.9 to 19 times rated capacities.

**High Signal-to-Noise Ratio:** Silicon strain gages provide a signal 75 times stronger than conventional foil gages. This signal is amplified, resulting in near-zero noise distortion.

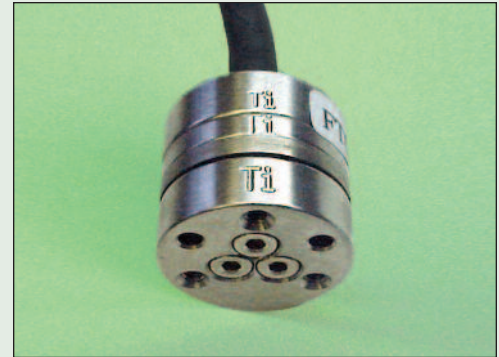

**The Nano17Ti F/T transducer**  
The transducer is made of grade 5 titanium.

## Typical Applications

- Biomechanical research
- Measurements in highly magnetic environments

ENGLISH CALIBRATIONS	SENSING RANGES		Calibrations					
	Axes		US-1.8-0.4		US-3.6-0.8		US-7.2-1.6	
	Fx, Fy (±lbf)		1.8		3.6		7.2	
	Fz (±lbf)		3.15		6.3		12.6	
	Tx, Ty (±lbf-in)		0.4		0.8		1.6	
	Tz (±lbf-in)		0.4		0.8		1.6	
	RESOLUTION		System Type*					
	Axes		CTL	Net/DAQ	CTL	Net/DAQ	CTL	Net/DAQ
	Fx, Fy (lbf)		1/1700	1/3400	1/850	1/1700	1/425	1/850
	Fz (lbf)		1/1360	1/2720	1/680	1/1360	1/340	1/680
Tx, Ty (lbf-in)		7/46400	7/92800	7/23200	7/46400	7/11600	7/23200	
Tz (lbf-in)		1/9280	1/18560	1/4640	1/9280	1/2320	1/4640	

METRIC CALIBRATIONS	SENSING RANGES		Calibrations					
	Axes		SI-8-0.05		SI-16-0.1		SI-32-0.2	
	Fx, Fy (±N)		8		16		32	
	Fz (±N)		14.1		28.2		56.4	
	Tx, Ty (±Nmm)		50		100		200	
	Tz (±Nmm)		50		100		200	
	RESOLUTION		System Type*					
	Axes		CTL	Net/DAQ	CTL	Net/DAQ	CTL	Net/DAQ
	Fx, Fy (N)		1/341	1/682	2/341	1/341	2/171	1/171
	Fz (N)		1/341	1/682	2/341	1/341	2/171	1/171
Tx, Ty (Nmm)		3/182	3/364	3/91	3/182	3/46	3/92	
Tz (Nmm)		5/364	5/728	5/182	5/364	5/92	5/184	

\*CTL: Controller F/T System; Net: Net F/T System; DAQ: 16-bit DAQ F/T System. The resolution is typical for most applications and can be improved with filtering. Resolutions quoted are the effective resolution after dropping four counts of noise (Net/DAQ) or eight counts of noise (CTL). All sensors calibrated by ATI.

**Applied loads must be within range in each of the six axes for the F/T sensor to measure correctly** (refer to the transducer manual for complex loading information).

Single-Axis Overload	English	Metric
F <sub>xy</sub>	±35 lbf	±160 N
F <sub>z</sub>	±70 lbf	±310 N
T <sub>xy</sub>	±8.9 lbf-in	±1 Nm
T <sub>z</sub>	±10 lbf-in	±1.2 Nm
Stiffness (Calculated)	English	Metric
X-axis & Y-axis force (K <sub>x</sub> , K <sub>y</sub> )	2.7x10 <sup>4</sup> lb/in	4.8x10 <sup>6</sup> N/m
Z-axis force (K <sub>z</sub> )	3.8x10 <sup>4</sup> lb/in	6.6x10 <sup>7</sup> N/m
X-axis & Y-axis torque (K <sub>tx</sub> , K <sub>ty</sub> )	1.2x10 <sup>3</sup> lbf-in/rad	1.4x10 <sup>2</sup> N/m/rad
Z-axis torque (K <sub>tz</sub> )	2.0x10 <sup>3</sup> lbf-in/rad	2.2x10 <sup>2</sup> N/m/rad
Resonant Frequency (Measured)		
F <sub>x</sub> , F <sub>y</sub> , T <sub>z</sub>	3000 Hz	
F <sub>z</sub> , T <sub>x</sub> , T <sub>y</sub>	3000 Hz	
Physical Specifications	English	Metric
Weight*	0.0223 lb	0.0101 kg
Diameter*	0.669 in	17 mm
Height*	0.571 in	14.5 mm

*“ATI force/torque sensors use simple ActiveX controls that make it compatible with Open Robot Control Architecture. Ease of integration, rugged design and excellent performance are reasons that many customers use these force sensors with our robots, and it is now even easier with our PC-based SeikoRCS robot controller.”*

Everette Phillips  
General Manager  
Seiko Robotics

\*Specifications are for non-IP rated models. Diameter excludes any connector or cable features.

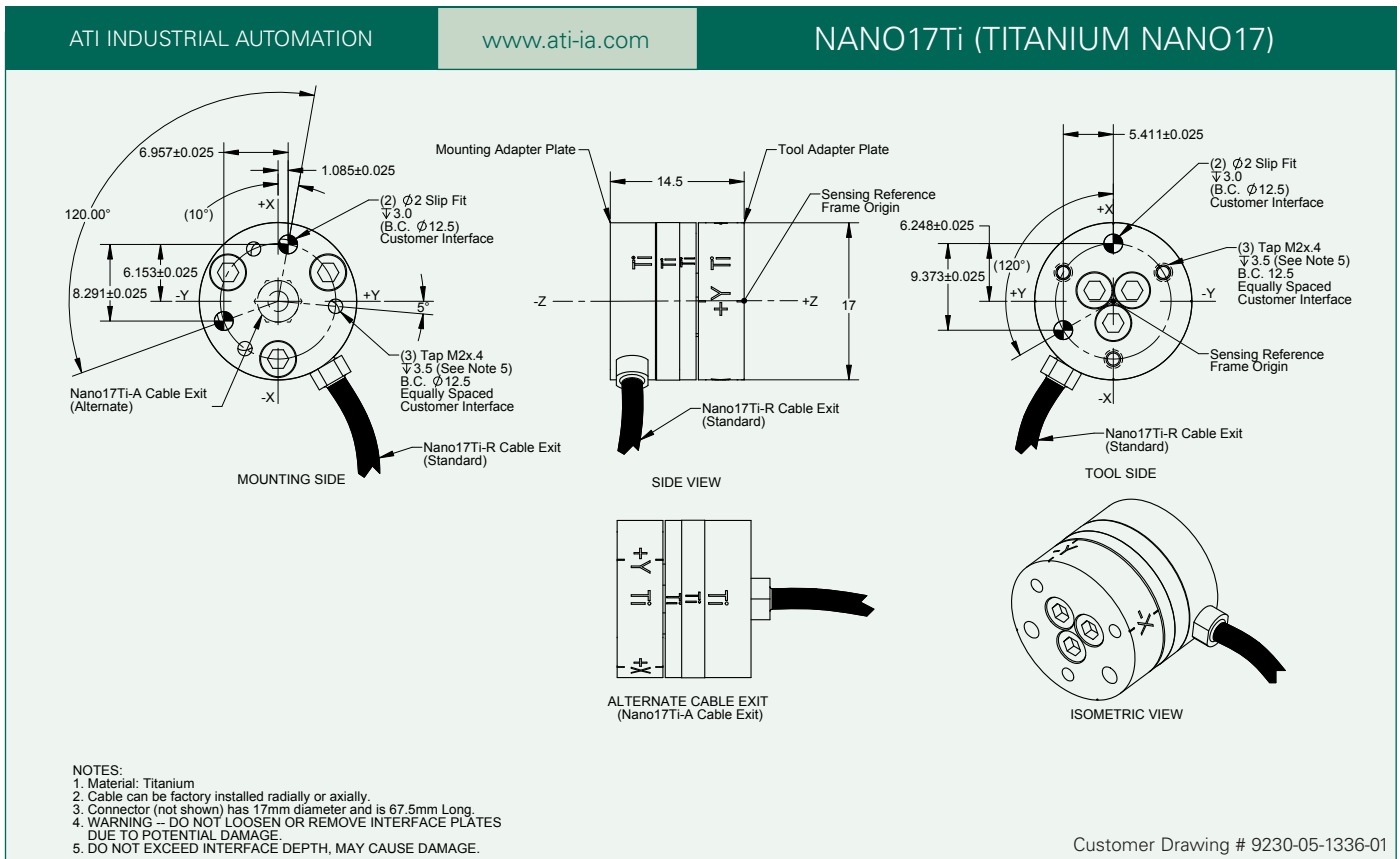

## Product Advantages

**One of the Smallest 6-Axis Sensors in the World:** The Nano17 fits into restricted spaces of research applications.

### Extremely High Strength:

- EDM wire-cut from high-yield-strength stainless steel.
- Maximum allowable single-axis overload values are 3.1 to 13 times rated capacities.

**High Signal-to-Noise Ratio:** Silicon strain gages provide a signal 75 times stronger than conventional foil gages. This signal is amplified, resulting in near-zero noise distortion.

**IP65 and IP68 (4m) Versions Available:** The IP65 version of the transducer is available for use in wet environments. The IP68 version is for underwater environments to a maximum depth of 4 meters in fresh water. Contact ATI Industrial Automation for drawings and more information.

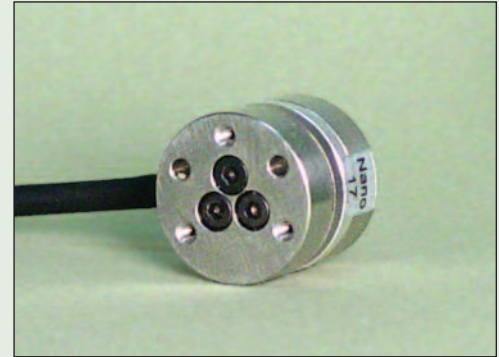

### The Nano17 F/T transducer

The transducer is made of hardened stainless steel, with integral interface plates made from high-strength aircraft aluminum.

## Typical Applications

- Dental research
- Robotic surgery
- Robotic hand research
- Finger-force research

ENGLISH CALIBRATIONS	SENSING RANGES		Calibrations											
	Axes		US-3-1		US-6-2		US-12-4							
	Fx, Fy (±lbf)		3		6		12							
	Fz (±lbf)		4.25		8.5		17							
	Tx, Ty (±lbf-in)		1		2		4							
	Tz (±lbf-in)		1		2		4							
	RESOLUTION		System Type*											
	Axes		CTL		Net/DAQ		CTL		Net/DAQ					
	Fx, Fy (lbf)		1/640		1/1280		1/320		1/640		1/160		1/320	
	Fz (lbf)		1/640		1/1280		1/320		1/640		1/160		1/320	
Tx, Ty (lbf-in)		1/4000		1/8000		1/2000		1/4000		1/1000		1/2000		
Tz (lbf-in)		1/4000		1/8000		1/2000		1/4000		1/1000		1/2000		

METRIC CALIBRATIONS	SENSING RANGES		Calibrations											
	Axes		SI-12-0.12		SI-25-0.25		SI-50-0.5							
	Fx, Fy (±N)		12		25		50							
	Fz (±N)		17		35		70							
	Tx, Ty (±Nmm)		120		250		500							
	Tz (±Nmm)		120		250		500							
	RESOLUTION		System Type*											
	Axes		CTL		Net/DAQ		CTL		Net/DAQ					
	Fx, Fy (N)		1/160		1/320		1/80		1/160		1/40		1/80	
	Fz (N)		1/160		1/320		1/80		1/160		1/40		1/80	
Tx, Ty (Nmm)		1/32		1/64		1/16		1/32		1/8		1/16		
Tz (Nmm)		1/32		1/64		1/16		1/32		1/8		1/16		

\*CTL: Controller F/T System; Net: Net F/T System; DAQ: 16-bit DAQ F/T System. The resolution is typical for most applications and can be improved with filtering. Resolutions quoted are the effective resolution after dropping four counts of noise (Net/DAQ) or eight counts of noise (CTL). All sensors calibrated by ATI.

**Applied loads must be within range in each of the six axes for the F/T sensor to measure correctly** (refer to the transducer manual for complex loading information).

Single-Axis Overload	English	Metric
F <sub>xy</sub>	±56 lbf	±250 N
F <sub>z</sub>	±110 lbf	±480 N
T <sub>xy</sub>	±14 lbf-in	±1.6 Nm
T <sub>z</sub>	±16 lbf-in	±1.8 Nm
Stiffness (Calculated)	English	Metric
X-axis & Y-axis force (K <sub>x</sub> , K <sub>y</sub> )	4.7x10 <sup>4</sup> lb/in	8.2x10 <sup>6</sup> N/m
Z-axis force (K <sub>z</sub> )	6.5x10 <sup>4</sup> lb/in	1.1x10 <sup>7</sup> N/m
X-axis & Y-axis torque (K <sub>tx</sub> , K <sub>ty</sub> )	2.1x10 <sup>3</sup> lbf-in/rad	2.4x10 <sup>2</sup> N/m/rad
Z-axis torque (K <sub>tz</sub> )	3.4x10 <sup>3</sup> lbf-in/rad	3.8x10 <sup>2</sup> N/m/rad
Resonant Frequency (Non-IP rated, Measured)		
F <sub>x</sub> , F <sub>y</sub> , T <sub>z</sub>	7200 Hz	
F <sub>z</sub> , T <sub>x</sub> , T <sub>y</sub>	7200 Hz	
Physical Specifications	English	Metric
Weight*	0.02 lb	0.00907 kg
Diameter*	0.669 in	17 mm
Height*	0.571 in	14.5 mm

*"I used the Nano17 in a recent design application. The support I received from ATI for my special application was excellent. The documentation was well-written, the installation and set-up was easy and the sensor proved to be robust and highly accurate for my application."*

Peter W. Johnson, PhD  
President  
Ergonomic Research and Consulting, Inc.

\*Specifications are for non-IP rated models. Diameter excludes any connector or cable features.

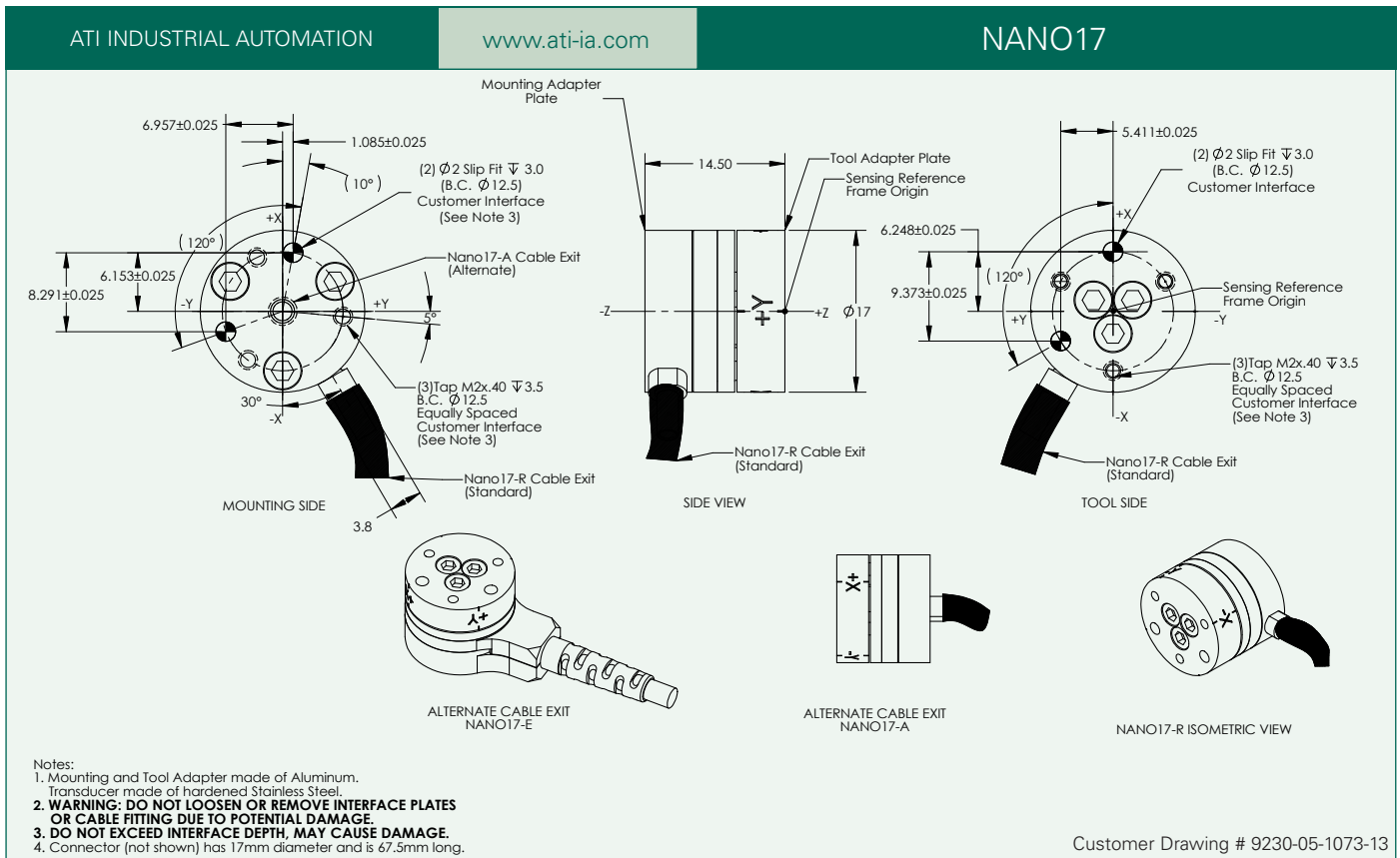

## Product Advantages

**One of the Smallest 6-Axis Sensors in the World:** The Nano25 fits into restricted spaces of research applications.

**Extremely High Strength:**

- EDM wire-cut from high-yield strength stainless steel.
- Maximum allowable single-axis overload values are 7.1 to 15 times rated capacities.

**High Signal-to-Noise Ratio:** Silicon strain gages provide a signal 75 times stronger than conventional foil gages. This signal is amplified, resulting in near-zero noise distortion.

**IP65 and IP68 (4m) Versions Available:** The IP65 version of the transducer is available for use in wet environments. The IP68 version is for underwater environments to a maximum depth of 4 meters in fresh water. Contact ATI Industrial Automation for drawings and more information.



**The Nano25 F/T transducer**

The transducer is made of hardened stainless steel with integral interface plates made from high-strength stainless steel.

## Typical Applications

- Telerobotics
- Robotic surgery
- Robotic hand research
- Finger-force research

ENGLISH CALIBRATIONS	SENSING RANGES		Calibrations			
	Axes		US-25-25		US-50-50	
	Fx, Fy ( $\pm$ lbf)		25		50	
	Fz ( $\pm$ lbf)		100		200	
	Tx, Ty ( $\pm$ lbf-in)		25		50	
	Tz ( $\pm$ lbf-in)		25		30	
	RESOLUTION		System Type*			
	Axes		CTL		Net/DAQ	
	Fx, Fy (lbf)		1/112		1/224	
	Fz (lbf)		3/112		3/224	
Tx, Ty (lbf-in)		1/80		1/160		
Tz (lbf-in)		1/160		1/320		

METRIC CALIBRATIONS	SENSING RANGES		Calibrations			
	Axes		SI-125-3		SI-250-6	
	Fx, Fy ( $\pm$ N)		125		250	
	Fz ( $\pm$ N)		500		1000	
	Tx, Ty ( $\pm$ Nm)		3		6	
	Tz ( $\pm$ Nm)		3		3.4	
	RESOLUTION		System Type*			
	Axes		CTL		Net/DAQ	
	Fx, Fy (N)		1/24		1/48	
	Fz (N)		1/8		1/16	
Tx, Ty (Nm)		1/660		1/1320		
Tz (Nm)		1/1320		1/2640		

\*CTL: Controller F/T System; Net: Net F/T System; DAQ: 16-bit DAQ F/T System. The resolution is typical for most applications and can be improved with filtering. Resolutions quoted are the effective resolution after dropping four counts of noise (Net/DAQ) or eight counts of noise (CTL). All sensors calibrated by ATI. **Applied loads must be within range in each of the six axes for the F/T sensor to measure correctly** (refer to the transducer manual for complex loading information).



Single-Axis Overload	English	Metric
Fxy	±520 lbf	±2300 N
Fz	±1600 lbf	±7300 N
Txy	±380 lbf-in	±43 Nm
Tz	±560 lbf-in	±63 Nm
Stiffness (Calculated)	English	Metric
X-axis & Y-axis force (Kx, Ky)	3.0x10 <sup>5</sup> lb/in	5.3x10 <sup>7</sup> N/m
Z-axis force (Kz)	6.3x10 <sup>5</sup> lb/in	1.1x10 <sup>8</sup> N/m
X-axis & Y-axis torque (Ktx, Kty)	5.7x10 <sup>4</sup> lbf-in/rad	6.5x10 <sup>3</sup> Nm/rad
Z-axis torque (Ktz)	8.1x10 <sup>4</sup> lbf-in/rad	9.2x10 <sup>3</sup> Nm/rad
Resonant Frequency (Non-IP rated, Measured)		
Fx, Fy, Tz	3600 Hz	
Fz, Tx, Ty	3800 Hz	
Physical Specifications	English	Metric
Weight*	0.14 lb	0.0634 kg
Diameter*	0.984 in	25 mm
Height*	0.85 in	21.6 mm

*“The forcetorque systems from ATI are ideal in our study of human grip force coordination and production. They are as close to a turn-key system as we have found.”*

Professor Jay L. Alberts  
Dept. of Exercise Science  
and Physical Education  
Arizona State University

**Note:**  
Applying moments beyond ±30 lbf-in (±3.4 Nm) in Tz can cause hysteresis and permanent zero-point change in the Nano25.

\*Specifications are for non-IP rated models. Diameter excludes any connector or cable features.

ATI INDUSTRIAL AUTOMATION
www.ati-ia.com
NANO25

**Notes:**

1. Mounting Adapter, Tool Adapter, and transducer made of Stainless Steel.
2. **WARNING: DO NOT LOOSEN OR REMOVE INTERFACE PLATES OR CABLE FITTING DUE TO POTENTIAL DAMAGE.**
3. **DO NOT EXCEED INTERFACE DEPTH, MAY CAUSE DAMAGE.**
4. Connector (not shown) has 17mm diameter and is 67.5mm long.

Customer Drawing # 9230-05-1083-13

## Product Advantages

**One of the Smallest 6-Axis Sensors in the World:** The Nano43 fits into restricted spaces of research applications and allows linkages and cables to pass through its center hole.

### Extremely High Strength:

- EDM wire-cut from high-yield strength stainless steel.
- Maximum allowable single-axis overload values are 6.4 to 28 times rated capacities.

**High Signal-to-Noise Ratio:** Silicon strain gages provide a signal 75 times stronger than conventional foil gages. This signal is amplified, resulting in near-zero noise distortion.

## Typical Applications

- Telerobotics
- Robotic surgery
- Robotic hand research
- Finger-force research



**The Nano43 F/T transducer**

The transducer is made of hardened stainless steel with integral interface plates made from high-strength aircraft aluminum.

ENGLISH CALIBRATIONS	SENSING RANGES		Calibrations					
	Axes		US-2-1		US-4-2		US-8-4	
	Fx, Fy ( $\pm$ lbf)		2		4		8	
	Fz ( $\pm$ lbf)		2		4		8	
	Tx, Ty ( $\pm$ lbf-in)		1		2		4	
	Tz ( $\pm$ lbf-in)		1		2		4	
	RESOLUTION		System Type*					
	Axes		CTL	Net/DAQ	CTL	Net/DAQ	CTL	Net/DAQ
	Fx, Fy (lbf)		1/1160	1/2320	1/580	1/1160	1/290	1/580
	Fz (lbf)		1/1160	1/2320	1/580	1/1160	1/290	1/580
Tx, Ty (lbf-in)		1/2320	1/4640	1/1160	1/2320	1/580	1/1160	
Tz (lbf-in)		1/2320	1/4640	1/1160	1/2320	1/580	1/1160	

METRIC CALIBRATIONS	SENSING RANGES		Calibrations					
	Axes		SI-9-0.125		SI-18-0.25		SI-36-0.5	
	Fx, Fy ( $\pm$ N)		9		18		36	
	Fz ( $\pm$ N)		9		18		36	
	Tx, Ty ( $\pm$ Nmm)		125		250		500	
	Tz ( $\pm$ Nmm)		125		250		500	
	RESOLUTION		System Type*					
	Axes		CTL	Net/DAQ	CTL	Net/DAQ	CTL	Net/DAQ
	Fx, Fy (N)		1/256	1/512	1/128	1/256	1/64	1/128
	Fz (N)		1/256	1/512	1/128	1/256	1/64	1/128
Tx, Ty (Nmm)		1/20	1/40	1/10	1/20	1/5	1/10	
Tz (Nmm)		1/20	1/40	1/10	1/20	1/5	1/10	

\*CTL: Controller F/T System; Net: Net F/T System; DAQ: 16-bit DAQ F/T System. The resolution is typical for most applications and can be improved with filtering. Resolutions quoted are the effective resolution after dropping four counts of noise (Net/DAQ) or eight counts of noise (CTL). All sensors calibrated by ATI.

**Applied loads must be within range in each of the six axes for the F/T sensor to measure correctly** (refer to the transducer manual for complex loading information).

Single-Axis Overload	English	Metric
F <sub>xy</sub>	±68 lbf	±300 N
F <sub>z</sub>	±86 lbf	±380 N
T <sub>xy</sub>	±29 lbf-in	±3.2 Nm
T <sub>z</sub>	±41 lbf-in	±4.6 Nm
Stiffness (Calculated)	English	Metric
X-axis & Y-axis force (K <sub>x</sub> , K <sub>y</sub> )	2.9x10 <sup>4</sup> lb/in	5.2x10 <sup>6</sup> N/m
Z-axis force (K <sub>z</sub> )	2.9x10 <sup>4</sup> lb/in	5.2x10 <sup>6</sup> N/m
X-axis & Y-axis torque (K <sub>tx</sub> , K <sub>ty</sub> )	6.8x10 <sup>3</sup> lbf-in/rad	7.7x10 <sup>2</sup> Nm/rad
Z-axis torque (K <sub>tz</sub> )	1.0x10 <sup>4</sup> lbf-in/rad	1.1x10 <sup>3</sup> Nm/rad
Resonant Frequency (Measured)		
F <sub>x</sub> , F <sub>y</sub> , T <sub>z</sub>	2800 Hz	
F <sub>z</sub> , T <sub>x</sub> , T <sub>y</sub>	2300 Hz	
Physical Specifications	English	Metric
Weight*	0.0854 lb	0.0387 kg
Diameter (OD, ID)*	1.69 in, 0.78 in	43 mm, 19.9 mm
Height*	0.454 in	11.5 mm

*“For high-resolution miniature 6 DOF force sensors, we’ve found ATI’s products to be the best commercially available.”*

Peter Berkelman, PhD  
Center for Computer-Integrated  
Surgical Systems and Technology  
Johns Hopkins University

\*Specifications are for non-IP rated models. Diameter excludes any connector or cable features.

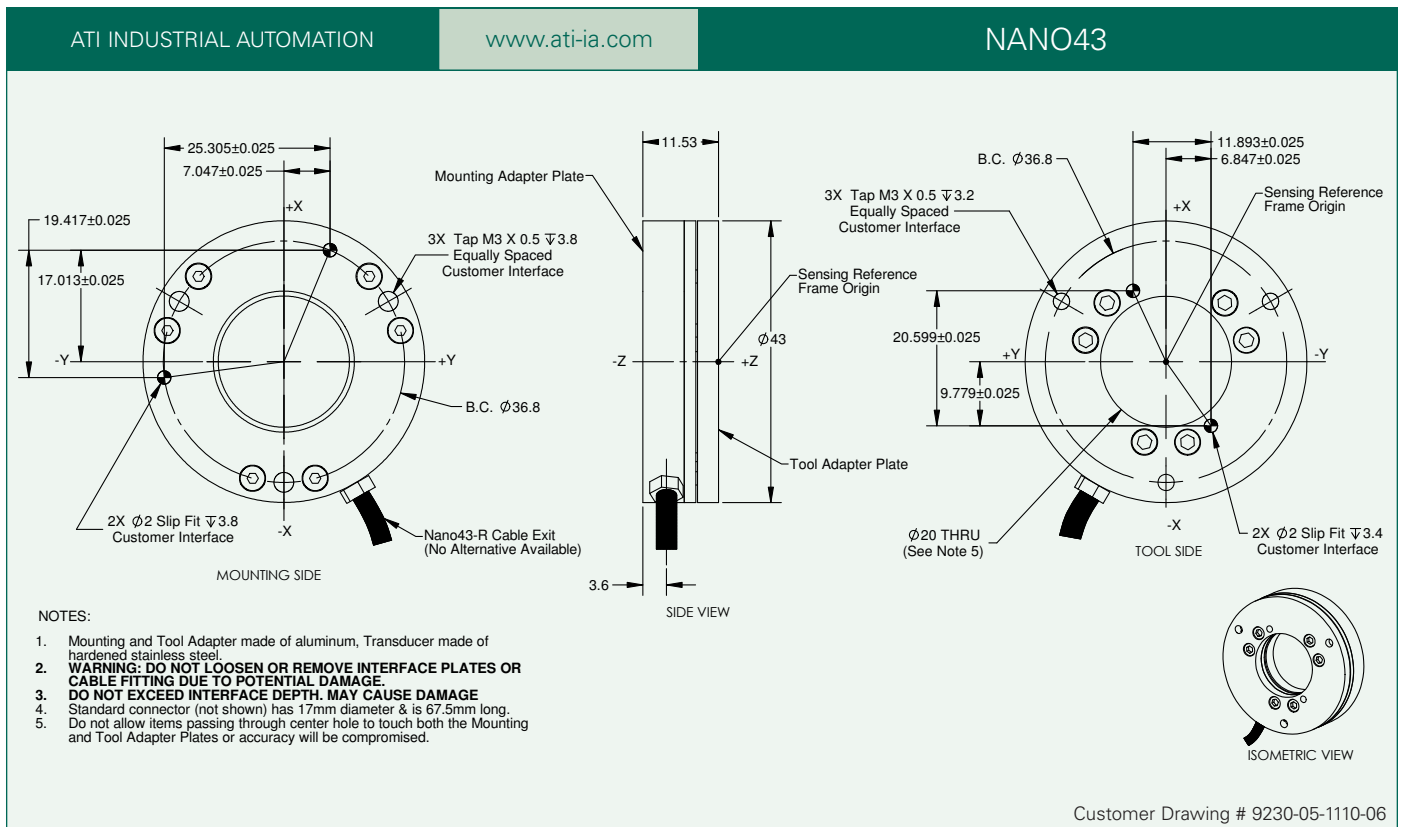

## Product Advantages

**One of the Smallest 6-Axis Sensors in the World:** The Mini40 has a compact, low-profile design.

### Extremely High Strength:

- EDM wire-cut from high-yield strength stainless steel.
- Maximum allowable single-axis overload values are 4.2 to 18 times rated capacities.

**High Signal-to-Noise Ratio:** Silicon strain gages provide a signal 75 times stronger than conventional foil gages. This signal is amplified, resulting in near-zero noise distortion.

**IP65 and IP68 (4m) Versions Available:** The IP65 version of the transducer is available for use in wet environments. The IP68 version is for underwater environments to a maximum depth of 4 meters in fresh water. Contact ATI Industrial Automation for drawings and more information.

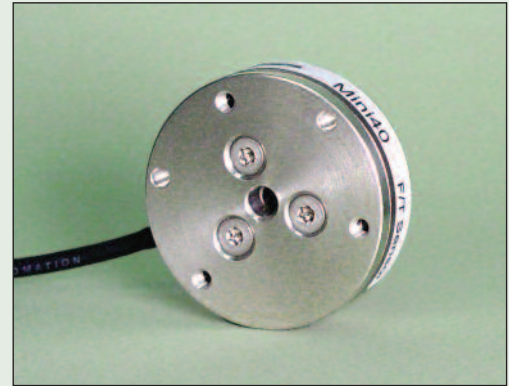

### The Mini40 F/T transducer

The transducer is made of hardened stainless steel with integral interface plates made from high-strength aircraft aluminum.

## Typical Applications

- Telerobotics
- Robotic surgery
- Robotic hand research
- Finger-force research

	SENSING RANGES		Calibrations					
	Axes		US-5-10		US-10-20		US-20-40	
ENGLISH CALIBRATIONS	Fx, Fy ( $\pm$ lbf)		5		10		20	
	Fz ( $\pm$ lbf)		15		30		60	
	Tx, Ty ( $\pm$ lbf-in)		10		20		40	
	Tz ( $\pm$ lbf-in)		10		20		40	
	RESOLUTION		System Type*					
Axes		CTL	Net/DAQ	CTL	Net/DAQ	CTL	Net/DAQ	
Fx, Fy (lbf)		1/400	1/800	1/200	1/400	1/100	1/200	
Fz (lbf)		1/200	1/400	1/100	1/200	1/50	1/100	
Tx, Ty (lbf-in)		1/400	1/800	1/200	1/400	1/100	1/200	
Tz (lbf-in)		1/400	1/800	1/200	1/400	1/100	1/200	

	SENSING RANGES		Calibrations					
	Axes		SI-20-1		SI-40-2		SI-80-4	
METRIC CALIBRATIONS	Fx, Fy ( $\pm$ N)		20		40		80	
	Fz ( $\pm$ N)		60		120		240	
	Tx, Ty ( $\pm$ Nm)		1		2		4	
	Tz ( $\pm$ Nm)		1		2		4	
	RESOLUTION		System Type*					
Axes		CTL	Net/DAQ	CTL	Net/DAQ	CTL	Net/DAQ	
Fx, Fy (N)		1/100	1/200	1/50	1/100	1/25	1/50	
Fz (N)		1/50	1/100	1/25	1/50	2/25	1/25	
Tx, Ty (Nm)		1/4000	1/8000	1/2000	1/4000	1/1000	1/2000	
Tz (Nm)		1/4000	1/8000	1/2000	1/4000	1/1000	1/2000	

\*CTL: Controller F/T System; Net: Net F/T System; DAQ: 16-bit DAQ F/T System. The resolution is typical for most applications and can be improved with filtering. Resolutions quoted are the effective resolution after dropping four counts of noise (Net/DAQ) or eight counts of noise (CTL). All sensors calibrated by ATI.

**Applied loads must be within range in each of the six axes for the F/T sensor to measure correctly** (refer to the transducer manual for complex loading information).

Single-Axis Overload	English	Metric
F <sub>xy</sub>	±180 lbf	±810 N
F <sub>z</sub>	±530 lbf	±2400 N
T <sub>xy</sub>	±170 lbf-in	±19 Nm
T <sub>z</sub>	±180 lbf-in	±20 Nm
Stiffness (Calculated)	English	Metric
X-axis & Y-axis force (K <sub>x</sub> , K <sub>y</sub> )	6.1x10 <sup>4</sup> lb/in	1.1x10 <sup>7</sup> N/m
Z-axis force (K <sub>z</sub> )	1.2x10 <sup>5</sup> lb/in	2.0x10 <sup>7</sup> N/m
X-axis & Y-axis torque (K <sub>tx</sub> , K <sub>ty</sub> )	2.5x10 <sup>4</sup> lbf-in/rad	2.8x10 <sup>3</sup> Nm/rad
Z-axis torque (K <sub>tz</sub> )	3.6x10 <sup>4</sup> lbf-in/rad	4.0x10 <sup>3</sup> Nm/rad
Resonant Frequency (Measured)		
F <sub>x</sub> , F <sub>y</sub> , T <sub>z</sub>	3200 Hz	
F <sub>z</sub> , T <sub>x</sub> , T <sub>y</sub>	4900 Hz	
Physical Specifications	English	Metric
Weight*	0.11 lb	0.0499 kg
Diameter*	1.57 in	40 mm
Height*	0.482 in	12.2 mm

*“ATI’s force transducers have given us high accuracy and easy-to-use tools that integrate perfectly with our research needs.”*

Dr. Douglas Weeks  
Dept. of Physical Therapy  
Regis University

\*Specifications are for non-IP rated models. Diameter excludes any connector or cable features.

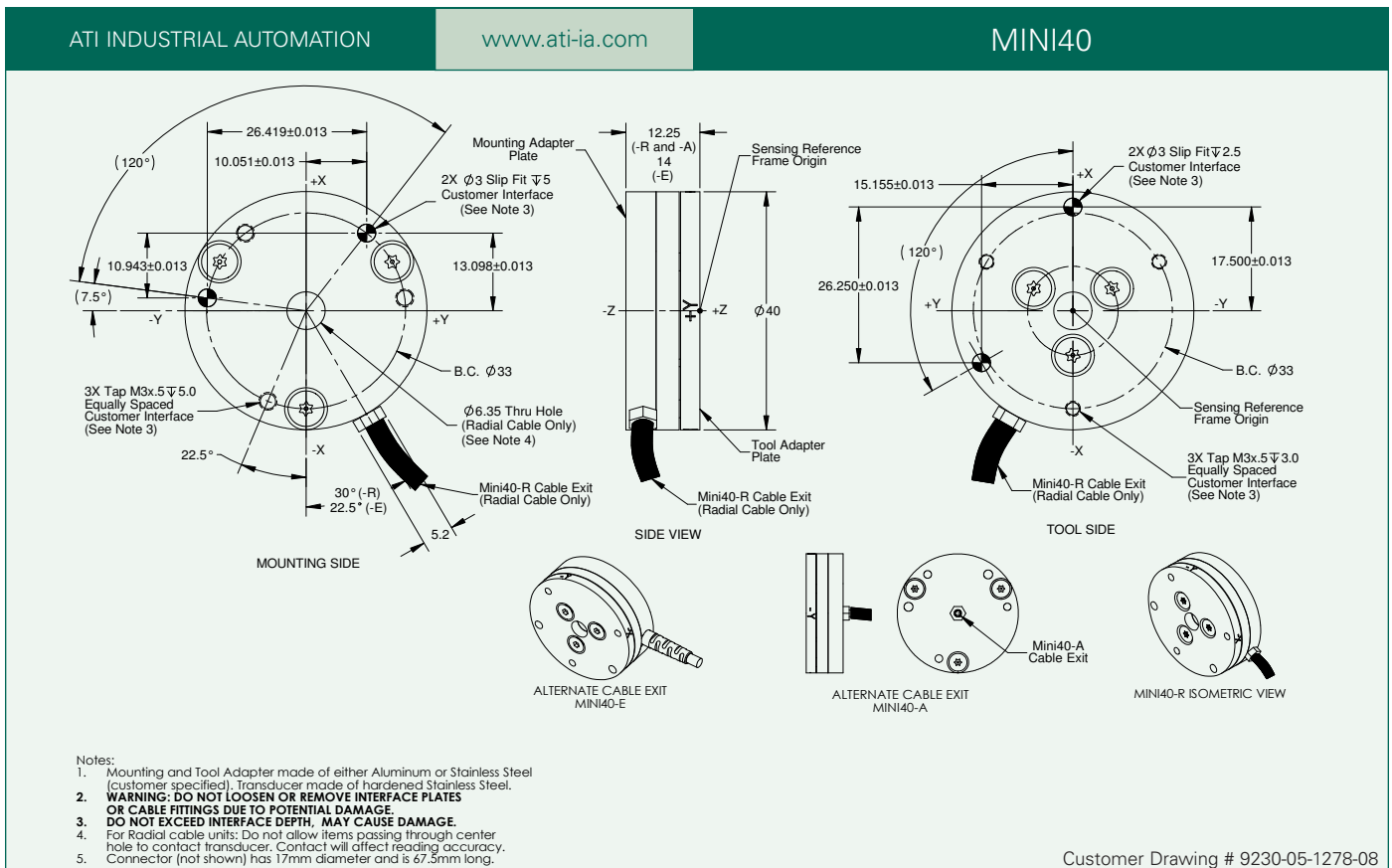

## Product Advantages

**One of the Smallest 6-Axis Sensors in the World:** The Mini45 has a compact, low-profile design with a through-hole to allow passage of linkages or cables.

### Extremely High Strength:

- EDM wire-cut from high-yield strength stainless steel.
- Maximum allowable single-axis overload values are 5.7 to 25 times rated capacities.

**High Signal-to-Noise Ratio:** Silicon strain gages provide a signal 75 times stronger than conventional foil gages. This signal is amplified, resulting in near-zero noise distortion.

**IP65 and IP68 (4m) Versions Available:** The IP65 version of the transducer is available for use in wet environments. The IP68 version is for underwater environments to a maximum depth of 4 meters in fresh water. Contact ATI Industrial Automation for drawings and more information.

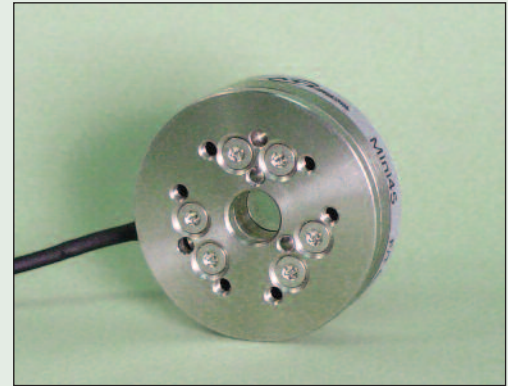

### The Mini45 F/T transducer

The transducer is made of hardened stainless steel with integral interface plates made from high-strength aircraft aluminum.

## Typical Applications

- Telerobotics
- Robotic surgery
- Robotic hand research
- Finger-force research

ENGLISH CALIBRATIONS	SENSING RANGES		Calibrations					
	Axes		US-30-40		US-60-80		US-120-160	
	Fx, Fy ( $\pm$ lbf)		30		60		120	
	Fz ( $\pm$ lbf)		60		120		240	
	Tx, Ty ( $\pm$ lbf-in)		40		80		160	
	Tz ( $\pm$ lbf-in)		40		80		160	
	RESOLUTION		System Type*					
	Axes		CTL	Net/DAQ	CTL	Net/DAQ	CTL	Net/DAQ
	Fx, Fy (lbf)		1/40	1/80	1/20	1/40	1/10	1/20
	Fz (lbf)		1/40	1/80	1/20	1/40	1/10	1/20
Tx, Ty (lbf-in)		1/44	1/88	1/22	1/44	1/11	1/22	
Tz (lbf-in)		1/88	1/176	1/44	1/88	1/22	1/44	

METRIC CALIBRATIONS	SENSING RANGES		Calibrations					
	Axes		SI-145-5		SI-290-10		SI-580-20	
	Fx, Fy ( $\pm$ N)		145		290		580	
	Fz ( $\pm$ N)		290		580		1160	
	Tx, Ty ( $\pm$ Nm)		5		10		20	
	Tz ( $\pm$ Nm)		5		10		20	
	RESOLUTION		System Type*					
	Axes		CTL	Net/DAQ	CTL	Net/DAQ	CTL	Net/DAQ
	Fx, Fy (N)		1/8	1/16	1/4	1/8	1/2	1/4
	Fz (N)		1/8	1/16	1/4	1/8	1/2	1/4
Tx, Ty (Nm)		1/376	1/752	1/188	1/376	1/94	1/188	
Tz (Nm)		1/752	1/1504	1/376	1/752	1/188	1/376	

\*CTL: Controller F/T System; Net: Net F/T System; DAQ: 16-bit DAQ F/T System. The resolution is typical for most applications and can be improved with filtering. Resolutions quoted are the effective resolution after dropping four counts of noise (Net/DAQ) or eight counts of noise (CTL). All sensors calibrated by ATI.

**Applied loads must be within range in each of the six axes for the F/T sensor to measure correctly** (refer to the transducer manual for complex loading information).

Single-Axis Overload	English	Metric
Fxy	±1100 lbf	±5100 N
Fz	±2300 lbf	±10000 N
Txy	±1000 lbf-in	±110 Nm
Tz	±1200 lbf-in	±140 Nm
Stiffness (Calculated)	English	Metric
X-axis & Y-axis force (Kx, Ky)	4.2x10 <sup>5</sup> lb/in	7.4x10 <sup>7</sup> N/m
Z-axis force (Kz)	5.6x10 <sup>5</sup> lb/in	9.8x10 <sup>7</sup> N/m
X-axis & Y-axis torque (Ktx, Kty)	1.5x10 <sup>5</sup> lbf-in/rad	1.7x10 <sup>4</sup> Nm/rad
Z-axis torque (Ktz)	3.1x10 <sup>5</sup> lbf-in/rad	3.5x10 <sup>4</sup> Nm/rad
Resonant Frequency (Measured)		
Fx, Fy, Tz	5600 Hz	
Fz, Tx, Ty	5400 Hz	
Physical Specifications	English	Metric
Weight*	0.202 lb	0.0917 kg
Diameter (OD, ID)*	1.77 in, 0.373 in	45 mm, 9.5 mm
Height*	0.618 in	15.7 mm

*“ATI’s sales support has been invaluable in helping us select the appropriate sensor and explaining detailed technical issues. I am extremely pleased with the ATI sensor we have chosen. It has enabled us to measure forces exerted by a physician, during a medical procedure, which have never been measured before.”*

Nathan Delson, PhD  
 Director, Mechanical Engineering  
 Design Center  
 University of California, San Diego  
 Department of Mechanical  
 and Aerospace Engineering

\*Specifications are for non-IP rated models. Diameter excludes any connector or cable features.

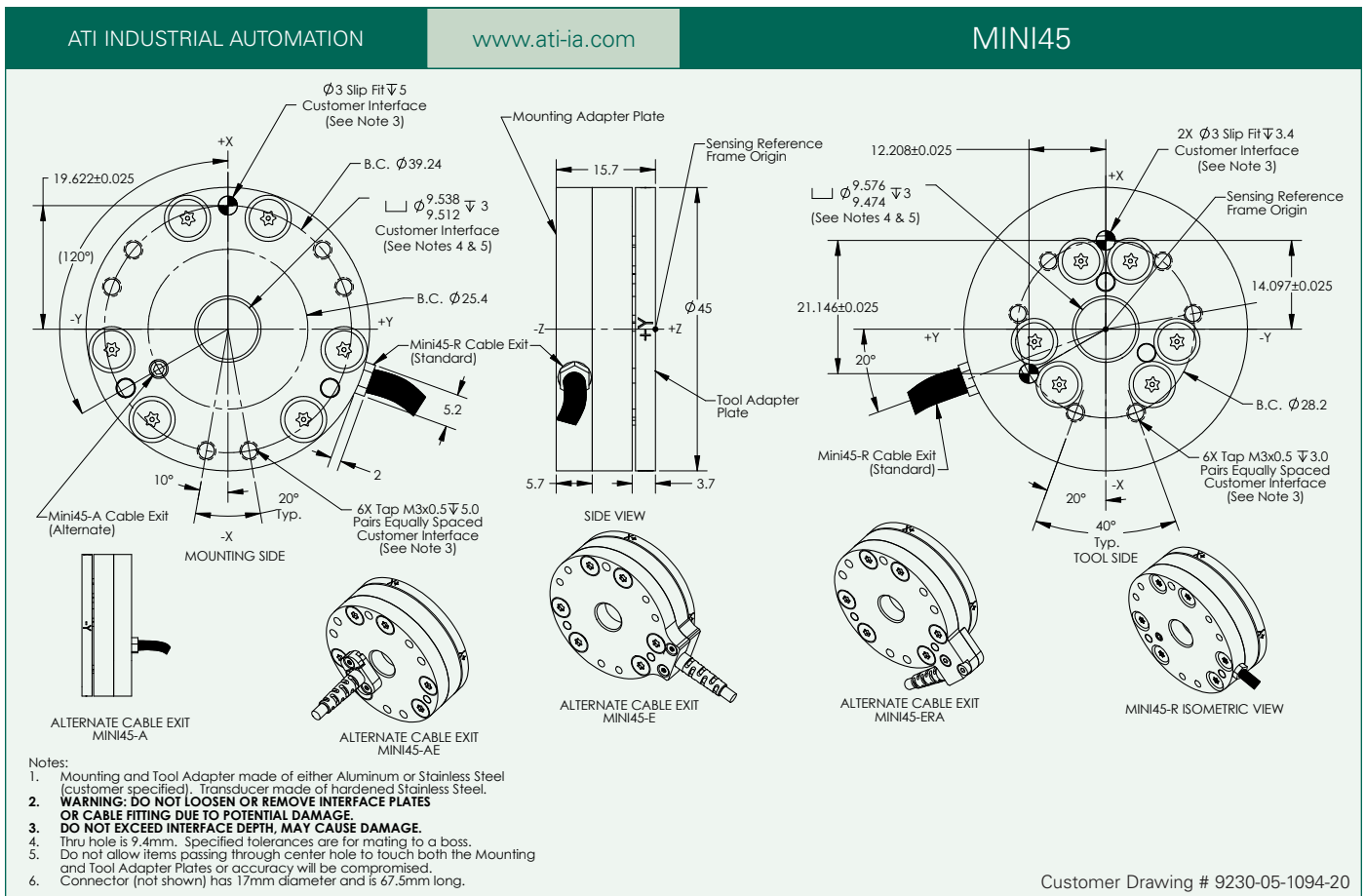

## Product Advantages

### Extremely High Strength:

- EDM wire-cut from high-yield strength stainless steel.
- Maximum allowable overload values are 4.9 to 21 times rated capacities.
- Through-hole to allow passage of linkages or cables.

**High Signal-to-Noise Ratio:** Silicon strain gages provide a signal 75 times stronger than conventional foil gages. This signal is amplified, resulting in near-zero noise distortion.

**IP60, IP65, and IP68 (4m) Versions Available:** An IP60 version is for use in dusty environments. The IP65 version of the transducer provides protection against water spray. The IP68 version is for underwater environments to a maximum depth of 4 meters in fresh water. Contact ATI Industrial Automation for drawings and more information.

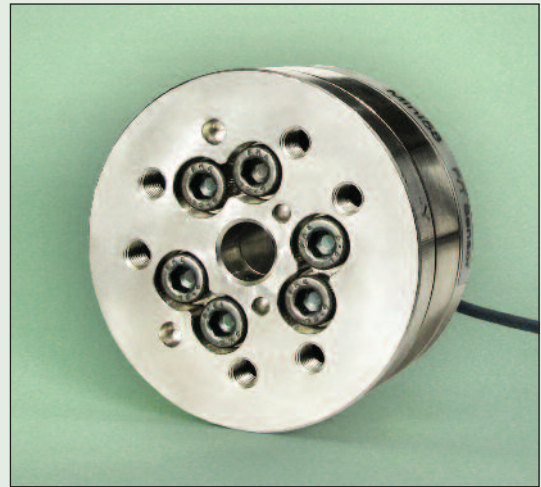

**The Mini58 F/T transducer**  
The transducer is made of hardened stainless steel.

## Typical Applications

- Telerobotics
- Robotic surgery
- Wind tunnel testing

ENGLISH CALIBRATIONS	SENSING RANGES		Calibrations											
	Axes		US-150-250		US-300-500		US-600-1000							
	Fx, Fy ( $\pm$ lbf)		150		300		600							
	Fz ( $\pm$ lbf)		375		750		1500							
	Tx, Ty ( $\pm$ lbf-in)		250		500		1000							
	Tz ( $\pm$ lbf-in)		250		500		1000							
	RESOLUTION		System Type*											
	Axes		CTL		Net/DAQ		CTL		Net/DAQ					
	Fx, Fy (lbf)		1/14		1/28		1/7		1/14		2/7		1/7	
	Fz (lbf)		3/28		3/56		3/14		3/28		3/7		3/14	
Tx, Ty (lbf-in)		1/12		1/24		1/6		1/12		1/3		1/6		
Tz (lbf-in)		1/20		1/40		1/10		1/20		1/5		1/10		

METRIC CALIBRATIONS	SENSING RANGES		Calibrations											
	Axes		SI-700-30		SI-1400-60		SI-2800-120							
	Fx, Fy ( $\pm$ N)		700		1400		2800							
	Fz ( $\pm$ N)		1700		3400		6800							
	Tx, Ty ( $\pm$ Nm)		30		60		120							
	Tz ( $\pm$ Nm)		30		60		120							
	RESOLUTION		System Type*											
	Axes		CTL		Net/DAQ		CTL		Net/DAQ					
	Fx, Fy (N)		1/3		1/6		2/3		1/3		1 1/2		3/4	
	Fz (N)		1/2		1/4		1		1/2		2		1	
Tx, Ty (Nm)		1/100		1/200		1/50		1/100		1/25		1/50		
Tz (Nm)		1/160		1/320		1/80		1/160		1/40		1/80		

\*CTL: Controller F/T System; Net: Net F/T System; DAQ: 16-bit DAQ F/T System. The resolution is typical for most applications and can be improved with filtering. Resolutions quoted are the effective resolution after dropping four counts of noise (Net/DAQ) or eight counts of noise (CTL). All sensors calibrated by ATI.  
**Applied loads must be within range in each of the six axes for the F/T sensor to measure correctly** (refer to the transducer manual for complex loading information).



Single-Axis Overload	English	Metric
F <sub>xy</sub>	±4800 lbf	±21000 N
F <sub>z</sub>	±11000 lbf	±48000 N
T <sub>xy</sub>	±5300 lbf-in	±590 Nm
T <sub>z</sub>	±7100 lbf-in	±800 Nm
Stiffness (Calculated)	English	Metric
X-axis & Y-axis force (K <sub>x</sub> , K <sub>y</sub> )	1.4x10 <sup>6</sup> lb/in	2.5x10 <sup>8</sup> N/m
Z-axis force (K <sub>z</sub> )	2.1x10 <sup>6</sup> lb/in	3.7x10 <sup>8</sup> N/m
X-axis & Y-axis torque (K <sub>tx</sub> , K <sub>ty</sub> )	9.3x10 <sup>5</sup> lbf-in/rad	1.1x10 <sup>5</sup> Nm/rad
Z-axis torque (K <sub>tz</sub> )	1.8x10 <sup>6</sup> lbf-in/rad	2.0x10 <sup>5</sup> Nm/rad
Resonant Frequency (Measured)		
F <sub>x</sub> , F <sub>y</sub> , T <sub>z</sub>	3000 Hz	
F <sub>z</sub> , T <sub>x</sub> , T <sub>y</sub>	5700 Hz	
Physical Specifications	English	Metric
Weight*	1.1 lb	0.499 kg
Diameter (OD, ID)*	2.28 in	58 mm
Height*	1.18 in	30 mm

\*Specifications are for non-IP rated models. Diameter excludes any connector or cable features.

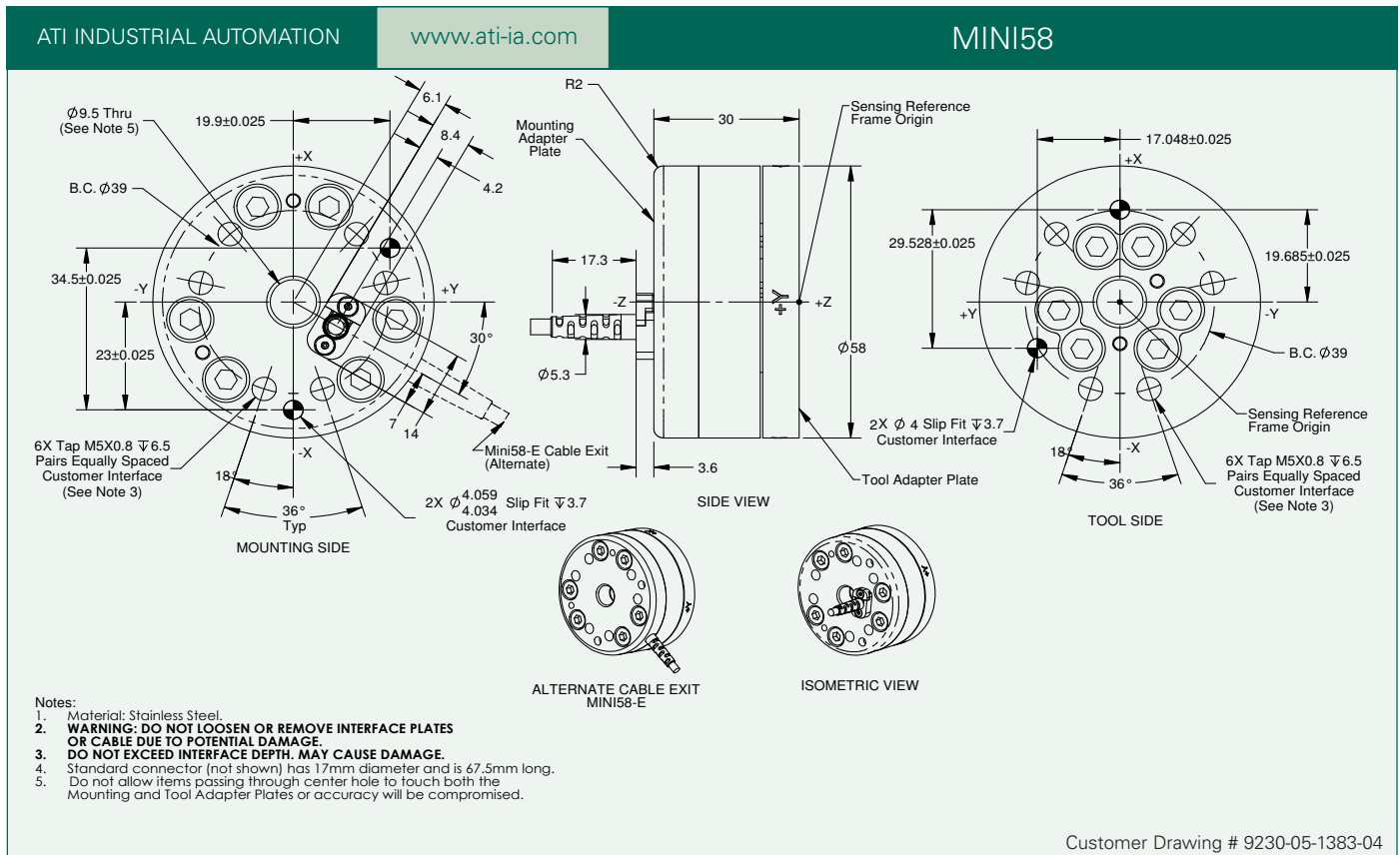

## Product Advantages

### Extremely High Strength:

- EDM wire-cut from high-yield strength stainless steel.
- Maximum allowable overload values are 5.9 to 25 times rated capacities.
- Through-hole available as a special order option.

**High Signal-to-Noise Ratio:** Silicon strain gages provide a signal 75 times stronger than conventional foil gages. This signal is amplified, resulting in near-zero noise distortion.

### Typical Applications

- Telerobotics
- Humanoid robots
- Rehabilitation research
- Prosthetics research



**The Mini85 F/T transducer**

The transducer is made of hardened stainless steel with integral interface plates made from high-strength aircraft aluminum.

ENGLISH CALIBRATIONS	SENSING RANGES		Calibrations					
	Axes		US-105-185		US-210-370		US-420-740	
	Fx, Fy ( $\pm$ lbf)		105		210		420	
	Fz ( $\pm$ lbf)		210		420		840	
	Tx, Ty ( $\pm$ lbf-in)		185		370		740	
	Tz ( $\pm$ lbf-in)		185		370		740	
	RESOLUTION		System Type*					
	Axes		CTL	Net/DAQ	CTL	Net/DAQ	CTL	Net/DAQ
	Fx, Fy (lbf)		1/26	1/52	5/64	5/128	5/32	5/64
	Fz (lbf)		7/130	7/260	3/32	3/64	3/16	3/32
Tx, Ty (lbf-in)		5/84	5/168	5/42	5/84	5/21	5/42	
Tz (lbf-in)		1/24	1/48	1/12	1/24	1/6	1/12	

METRIC CALIBRATIONS	SENSING RANGES		Calibrations					
	Axes		SI-475-20		SI-950-40		SI-1900-80	
	Fx, Fy ( $\pm$ N)		475		950		1900	
	Fz ( $\pm$ N)		950		1900		3800	
	Tx, Ty ( $\pm$ Nm)		20		40		80	
	Tz ( $\pm$ Nm)		20		40		80	
	RESOLUTION		System Type*					
	Axes		CTL	Net/DAQ	CTL	Net/DAQ	CTL	Net/DAQ
	Fx, Fy (N)		9/56	9/112	9/28	9/56	9/14	9/28
	Fz (N)		3/14	3/28	3/7	3/14	6/7	3/7
Tx, Ty (Nm)		5/748	5/1496	5/374	5/748	5/187	5/374	
Tz (Nm)		7/1496	7/2992	7/748	7/1496	7/374	7/748	

\*CTL: Controller F/T System; Net: Net F/T System; DAQ: 16-bit DAQ F/T System. The resolution is typical for most applications and can be improved with filtering. Resolutions quoted are the effective resolution after dropping four counts of noise (Net/DAQ) or eight counts of noise (CTL). All sensors calibrated by ATI.

**Applied loads must be within range in each of the six axes for the F/T sensor to measure correctly** (refer to the transducer manual for complex loading information).

Single-Axis Overload	English	Metric
F <sub>xy</sub>	±2800 lbf	±13000 N
F <sub>z</sub>	±6100 lbf	±27000 N
T <sub>xy</sub>	±4400 lbf-in	±500 Nm
T <sub>z</sub>	±5400 lbf-in	±610 Nm
Stiffness (Calculated)	English	Metric
X-axis & Y-axis force (K <sub>x</sub> , K <sub>y</sub> )	4.4x10 <sup>5</sup> lb/in	7.7x10 <sup>7</sup> N/m
Z-axis force (K <sub>z</sub> )	6.8x10 <sup>5</sup> lb/in	1.2x10 <sup>8</sup> N/m
X-axis & Y-axis torque (K <sub>tx</sub> , K <sub>ty</sub> )	7.2x10 <sup>5</sup> lbf-in/rad	8.1x10 <sup>4</sup> Nm/rad
Z-axis torque (K <sub>tz</sub> )	1.2x10 <sup>6</sup> lbf-in/rad	1.3x10 <sup>5</sup> Nm/rad
Resonant Frequency (Measured)		
F <sub>x</sub> , F <sub>y</sub> , T <sub>z</sub>	2400 Hz	
F <sub>z</sub> , T <sub>x</sub> , T <sub>y</sub>	3100 Hz	
Physical Specifications	English	Metric
Weight*	1.4 lb	0.635 kg
Diameter*	3.35 in	85.1 mm
Height*	1.17 in	29.8 mm

*“ATI’s products and knowledgeable staff were instrumental in allowing us to rapidly prototype our latest surgical robotic platform. Because of their off-the-shelf solutions for miniature force and torque sensing, we were able to go from concept to working prototype in months instead of years.”*

Patrick Jensen, PhD  
Assistant Professor of Ophthalmology  
Johns Hopkins University

\*Specifications are for non-IP rated models. Diameter excludes any connector or cable features.

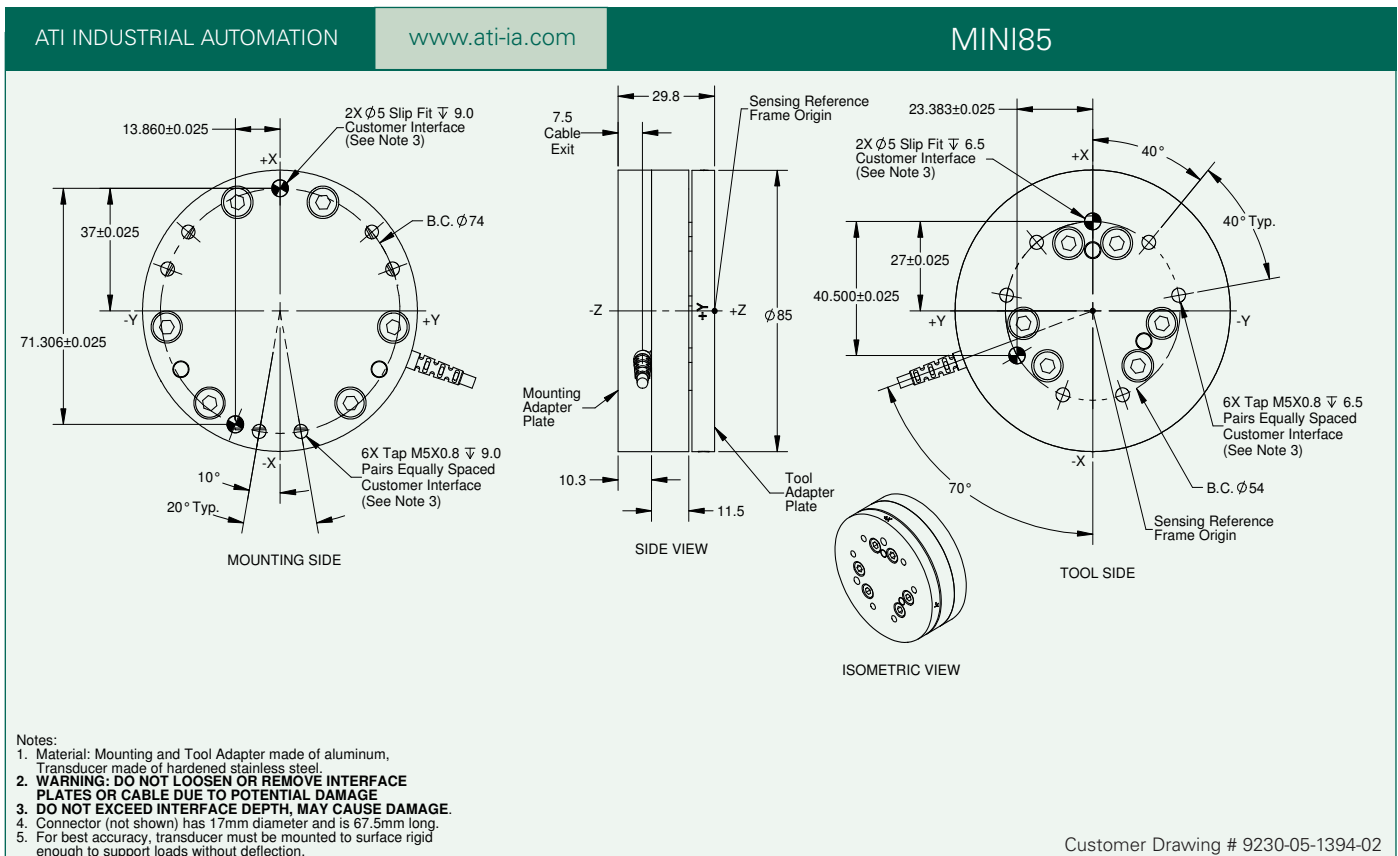

## Product Advantages

### Extremely High Strength:

- Precision machined from high-strength aircraft aluminum.
- Maximum allowable single-axis overload values are 6.9 to 31 times rated capacities.

**High Signal-to-Noise Ratio:** Silicon strain gages provide a signal 75 times stronger than conventional foil gages. This signal is amplified, resulting in near-zero noise distortion.

**IP60, IP65, and IP68 (4m) Versions Available:** An IP60 version is for use in dusty environments. The IP65 version of the transducer provides protection against water spray. The IP68 version is for underwater environments to a maximum depth of 4 meters in fresh water. Contact ATI Industrial Automation for drawings and more information.



**The Gamma F/T transducer**

The transducer and the standard mounting adapter are made of high-strength aircraft aluminum.

## Typical Applications

- Real-time force control
- Robotic assembly
- Prosthetic device testing
- Haptics feedback
- Automotive part testing

	SENSING RANGES		Calibrations										
	Axes		US-7.5-25		US-15-50		US-30-100						
ENGLISH CALIBRATIONS	Fx, Fy ( $\pm$ lbf)		7.5		15		30						
	Fz ( $\pm$ lbf)		25		50		100						
	Tx, Ty ( $\pm$ lbf-in)		25		50		100						
	Tz ( $\pm$ lbf-in)		25		50		100						
	RESOLUTION		System Type*										
Axes		CTL		Net/DAQ		CTL		Net/DAQ					
Fx, Fy (lbf)		1/320		1/640		1/160		1/320		1/80		1/160	
Fz (lbf)		1/160		1/320		1/80		1/160		1/40		1/80	
Tx, Ty (lbf-in)		1/160		1/320		1/80		1/160		1/40		1/80	
Tz (lbf-in)		1/160		1/320		1/80		1/160		1/40		1/80	

	SENSING RANGES		Calibrations										
	Axes		SI-32-2.5		SI-65-5		SI-130-10						
METRIC CALIBRATIONS	Fx, Fy ( $\pm$ N)		32		65		130						
	Fz ( $\pm$ N)		100		200		400						
	Tx, Ty ( $\pm$ Nm)		2.5		5		10						
	Tz ( $\pm$ Nm)		2.5		5		10						
	RESOLUTION		System Type*										
Axes		CTL		Net/DAQ		CTL		Net/DAQ					
Fx, Fy (N)		1/80		1/160		1/40		1/80		1/20		1/40	
Fz (N)		1/40		1/80		1/20		1/40		1/10		1/20	
Tx, Ty (Nm)		1/1000		1/2000		5/3333		10/13333		1/400		1/800	
Tz (Nm)		1/1000		1/2000		5/3333		10/13333		1/400		1/800	

\*CTL: Controller F/T System; Net: Net F/T System; DAQ: 16-bit DAQ F/T System. The resolution is typical for most applications and can be improved with filtering. Resolutions quoted are the effective resolution after dropping four counts of noise (Net/DAQ) or eight counts of noise (CTL). All sensors calibrated by ATI.

**Applied loads must be within range in each of the six axes for the F/T sensor to measure correctly** (refer to the transducer manual for complex loading information).

Single-Axis Overload	English	Metric
F <sub>xy</sub>	±280 lbf	±1200 N
F <sub>z</sub>	±930 lbf	±4100 N
T <sub>xy</sub>	±700 lbf-in	±79 Nm
T <sub>z</sub>	±730 lbf-in	±82 Nm
Stiffness (Calculated)	English	Metric
X-axis & Y-axis force (K <sub>x</sub> , K <sub>y</sub> )	5.2x10 <sup>4</sup> lb/in	9.1x10 <sup>6</sup> N/m
Z-axis force (K <sub>z</sub> )	1.0x10 <sup>5</sup> lb/in	1.8x10 <sup>7</sup> N/m
X-axis & Y-axis torque (K <sub>tx</sub> , K <sub>ty</sub> )	9.3x10 <sup>4</sup> lbf-in/rad	1.1x10 <sup>4</sup> Nm/rad
Z-axis torque (K <sub>tz</sub> )	1.4x10 <sup>5</sup> lbf-in/rad	1.6x10 <sup>4</sup> Nm/rad
Resonant Frequency (Non-IP rated, Measured)		
F <sub>x</sub> , F <sub>y</sub> , T <sub>z</sub>	1400 Hz	
F <sub>z</sub> , T <sub>x</sub> , T <sub>y</sub>	2000 Hz	
Physical Specifications	English	Metric
Weight*	0.562 lb	0.255 kg
Diameter*	2.97 in	75.4 mm
Height*	1.31 in	33.3 mm

*"I highly recommend ATI's forcetorque transducers to anyone who needs a reliable, pre-calibrated, easily programmable transducer. It is a truly versatile plug-and-play system."*

Prof. Francisco Valera-Cuevas  
Neuromuscular Biomechanics Laboratory  
Cornell University

\*Specifications include standard interface plates and are for non-IP rated models. Diameter excludes any connector block.

ATI INDUSTRIAL AUTOMATION
www.ati-ia.com
GAMMA

**Notes:**

1. Material: Aluminum.
2. Do Not Touch internal electronics or instrumentation this could damage the transducer and will void the warranty.
3. **DO NOT EXCEED INTERFACE DEPTH, MAY CAUSE DAMAGE.**
4. Transducer must be mounted to surfaces rigid enough to support loads without deflection for best accuracy.

Customer Drawing # 9230-05-1329-02

## Product Advantages

### Extremely High Strength:

- Precision machined from high-strength aircraft aluminum.
- Maximum allowable single-axis overload values are 4.1 to 18 times rated capacities.

**High Signal-to-Noise Ratio:** Silicon strain gages provide a signal 75 times stronger than conventional foil gages. This signal is amplified, resulting in near-zero noise distortion.

**IP60, IP65, and IP68 (10m) Versions Available:** An IP60 version is for use in dusty environments. The IP65 version of the transducer provides protection against water spray. The IP68 version is for underwater environments to a maximum depth of 10 meters in fresh water. Contact ATI Industrial Automation for drawings and more information.

### Typical Applications

- Real-time force control
- Robotic assembly
- Haptics feedback
- Rehabilitation research



### The Delta F/T transducer

The transducer is made of hardened stainless steel, and the standard mounting adapter is made of high-strength aircraft aluminum.

ENGLISH CALIBRATIONS	SENSING RANGES		Calibrations					
	Axes		US-50-150		US-75-300		US-150-600	
	Fx, Fy ( $\pm$ lbf)		50		75		150	
	Fz ( $\pm$ lbf)		150		225		450	
	Tx, Ty ( $\pm$ lbf-in)		150		300		600	
	Tz ( $\pm$ lbf-in)		150		300		600	
	RESOLUTION		System Type*					
	Axes		CTL	Net/DAQ	CTL	Net/DAQ	CTL	Net/DAQ
	Fx, Fy (lbf)		1/64	1/128	1/32	1/64	1/16	1/32
	Fz (lbf)		1/32	1/64	1/16	1/32	1/8	1/16
Tx, Ty (lbf-in)		3/64	3/128	3/32	3/64	3/16	3/32	
Tz (lbf-in)		1/32	1/64	1/16	1/32	1/8	1/16	

METRIC CALIBRATIONS	SENSING RANGES		Calibrations					
	Axes		SI-165-15		SI-330-30		SI-660-60	
	Fx, Fy ( $\pm$ N)		165		330		660	
	Fz ( $\pm$ N)		495		990		1980	
	Tx, Ty ( $\pm$ Nm)		15		30		60	
	Tz ( $\pm$ Nm)		15		30		60	
	RESOLUTION		System Type*					
	Axes		CTL	Net/DAQ	CTL	Net/DAQ	CTL	Net/DAQ
	Fx, Fy (N)		1/16	1/32	1/8	1/16	1/4	1/8
	Fz (N)		1/8	1/16	1/4	1/8	1/2	1/4
Tx, Ty (Nm)		1/264	1/528	10/1333	5/1333	5/333	10/1333	
Tz (Nm)		1/264	1/528	10/1333	5/1333	5/333	10/1333	

\*CTL: Controller F/T System; Net: Net F/T System; DAQ: 16-bit DAQ F/T System. The resolution is typical for most applications and can be improved with filtering. Resolutions quoted are the effective resolution after dropping four counts of noise (Net/DAQ) or eight counts of noise (CTL). All sensors calibrated by ATI.

**Applied loads must be within range in each of the six axes for the F/T sensor to measure correctly** (refer to the transducer manual for complex loading information).

Single-Axis Overload	English	Metric
Fxy	±840 lbf	±3700 N
Fz	±2300 lbf	±10000 N
Txy	±2500 lbf-in	±280 Nm
Tz	±3600 lbf-in	±400 Nm
Stiffness (Calculated)	English	Metric
X-axis & Y-axis force (Kx, Ky)	2.0x10 <sup>5</sup> lb/in	3.6x10 <sup>7</sup> N/m
Z-axis force (Kz)	3.4x10 <sup>5</sup> lb/in	5.9x10 <sup>7</sup> N/m
X-axis & Y-axis torque (Ktx, Kty)	4.6x10 <sup>5</sup> lbf-in/rad	5.2x10 <sup>4</sup> Nm/rad
Z-axis torque (Ktz)	8.1x10 <sup>5</sup> lbf-in/rad	9.1x10 <sup>4</sup> Nm/rad
Resonant Frequency (Non-IP rated, Measured)		
Fx, Fy, Tz	1500 Hz	
Fz, Tx, Ty	1700 Hz	
Physical Specifications	English	Metric
Weight*	2.01 lb	0.913 kg
Diameter*	3.72 in	94.5 mm
Height*	1.31 in	33.3 mm

*"I use the ATI Delta force transducers to measure multi-axial forces and moments applied by the foot during pedaling of an experimental bicycle ergometer. These transducers are a simple, accurate, and cost-effective measurement tool and they enable me to collect data on movement behavior in healthy individuals and persons with post-stroke hemiparesis."*

David A. Brown, PT, PhD  
Physical Therapist Scientist

\*Specifications include standard interface plates and are for non-IP rated models. Diameter excludes any connector block.

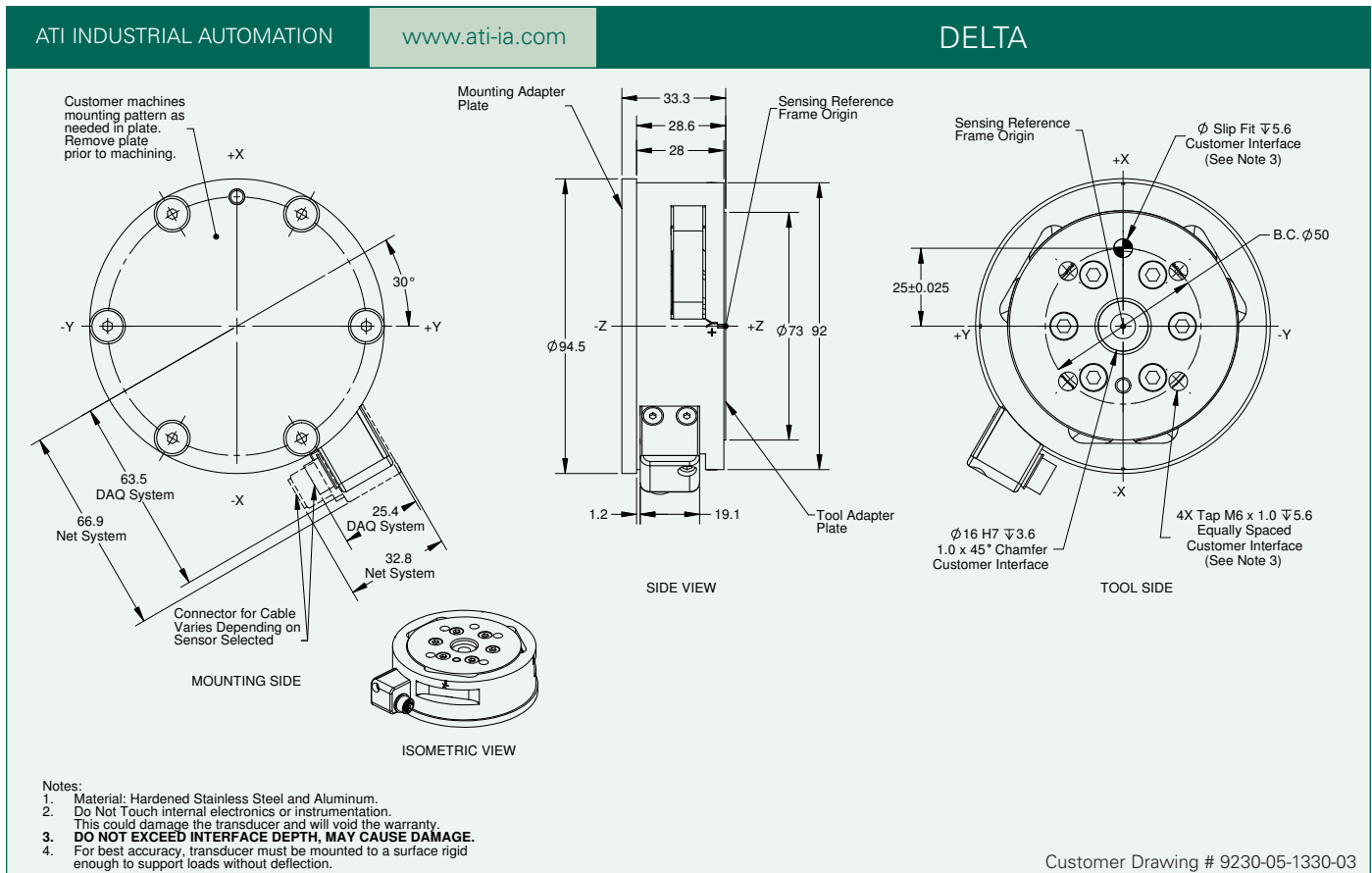

## Product Advantages

### Extremely High Strength:

- Precision machined from high-strength stainless steel.
- Maximum allowable single-axis overload values are 4.8 to 17 times rated capacities.

**High Signal-to-Noise Ratio:** Silicon strain gages provide a signal 75 times stronger than conventional foil gages. This signal is amplified, resulting in near-zero noise distortion.

**IP60, IP65, and IP68 (10m) Versions Available:** An IP60 version is for use in dusty environments. The IP65 version of the transducer provides protection against water spray. The IP68 version is for underwater environments to a maximum depth of 10 meters in fresh water. Contact ATI Industrial Automation for drawings and more information.

### Typical Applications

- Rehabilitation research
- Product testing
- Orthopedic research
- Robotic assembly
- Telerobotics
- Part placement and removal in precision fixtures



#### The Theta F/T transducer

The transducer is made of hardened stainless steel, with integral interface plates made from high-strength stainless steel.

	SENSING RANGES		Calibrations											
	Axes		US-200-1000		US-300-1800		US-600-3600							
ENGLISH CALIBRATIONS	Fx, Fy ( $\pm$ lbf)		200		300		600							
	Fz ( $\pm$ lbf)		500		875		1500							
	Tx, Ty ( $\pm$ lbf-in)		1000		1800		3600							
	Tz ( $\pm$ lbf-in)		1000		1800		3600							
	RESOLUTION		System Type*											
	Axes		CTL		Net/DAQ		CTL		Net/DAQ					
	Fx, Fy (lbf)		1/16		1/32		5/34		5/68		1/4		1/8	
	Fz (lbf)		1/8		1/16		5/17		5/34		1/2		1/4	
	Tx, Ty (lbf-in)		1/4		1/8		5/8		5/16		1		1/2	
	Tz (lbf-in)		1/4		1/8		5/8		5/16		1		1/2	

	SENSING RANGES		Calibrations											
	Axes		SI-1000-120		SI-1500-240		SI-2500-400							
METRIC CALIBRATIONS	Fx, Fy ( $\pm$ N)		1000		1500		2500							
	Fz ( $\pm$ N)		2500		3750		6250							
	Tx, Ty ( $\pm$ Nm)		120		240		400							
	Tz ( $\pm$ Nm)		120		240		400							
	RESOLUTION		System Type*											
	Axes		CTL		Net/DAQ		CTL		Net/DAQ					
	Fx, Fy (N)		1/2		1/4		1		1/2		1		1/2	
	Fz (N)		1/2		1/4		1		1/2		2		1	
	Tx, Ty (Nm)		1/20		1/40		1/10		1/20		1/10		1/20	
	Tz (Nm)		1/40		1/80		1/20		1/40		1/10		1/20	

\*CTL: Controller F/T System; Net: Net F/T System; DAQ: 16-bit DAQ F/T System. The resolution is typical for most applications and can be improved with filtering. Resolutions quoted are the effective resolution after dropping four counts of noise (Net/DAQ) or eight counts of noise (CTL). All sensors calibrated by ATI. **Applied loads must be within range in each of the six axes for the F/T sensor to measure correctly** (refer to the transducer manual for complex loading information).



Single-Axis Overload	English	Metric
Fxy	±4500 lbf	±20000 N
Fz	±11000 lbf	±51000 N
Txy	±18000 lbf-in	±2000 Nm
Tz	±18000 lbf-in	±2000 Nm
Stiffness (Calculated)	English	Metric
X-axis & Y-axis force (Kx, Ky)	4.0x10 <sup>5</sup> lb/in	7.1x10 <sup>7</sup> N/m
Z-axis force (Kz)	6.9x10 <sup>5</sup> lb/in	1.2x10 <sup>8</sup> N/m
X-axis & Y-axis torque (Ktx, Kty)	3.0x10 <sup>6</sup> lbf-in/rad	3.4x10 <sup>5</sup> Nm/rad
Z-axis torque (Ktz)	4.7x10 <sup>6</sup> lbf-in/rad	5.3x10 <sup>5</sup> Nm/rad
Resonant Frequency (Non-IP rated, Measured)		
Fx, Fy, Tz	680 Hz	
Fz, Tx, Ty	820 Hz	
Physical Specifications	English	Metric
Weight*	11.0 lb	4.99 kg
Diameter*	6.1 in	155 mm
Height*	2.41 in	61.1 mm

*“We have been using the ATI F/T for automotive seat testing since 1998. We are impressed with its ruggedness and reliability.”*

Kevin Moore  
Automotive Testing Technologies

\*Specifications include standard interface plates and are for non-IP rated models. Diameter excludes any connector block.

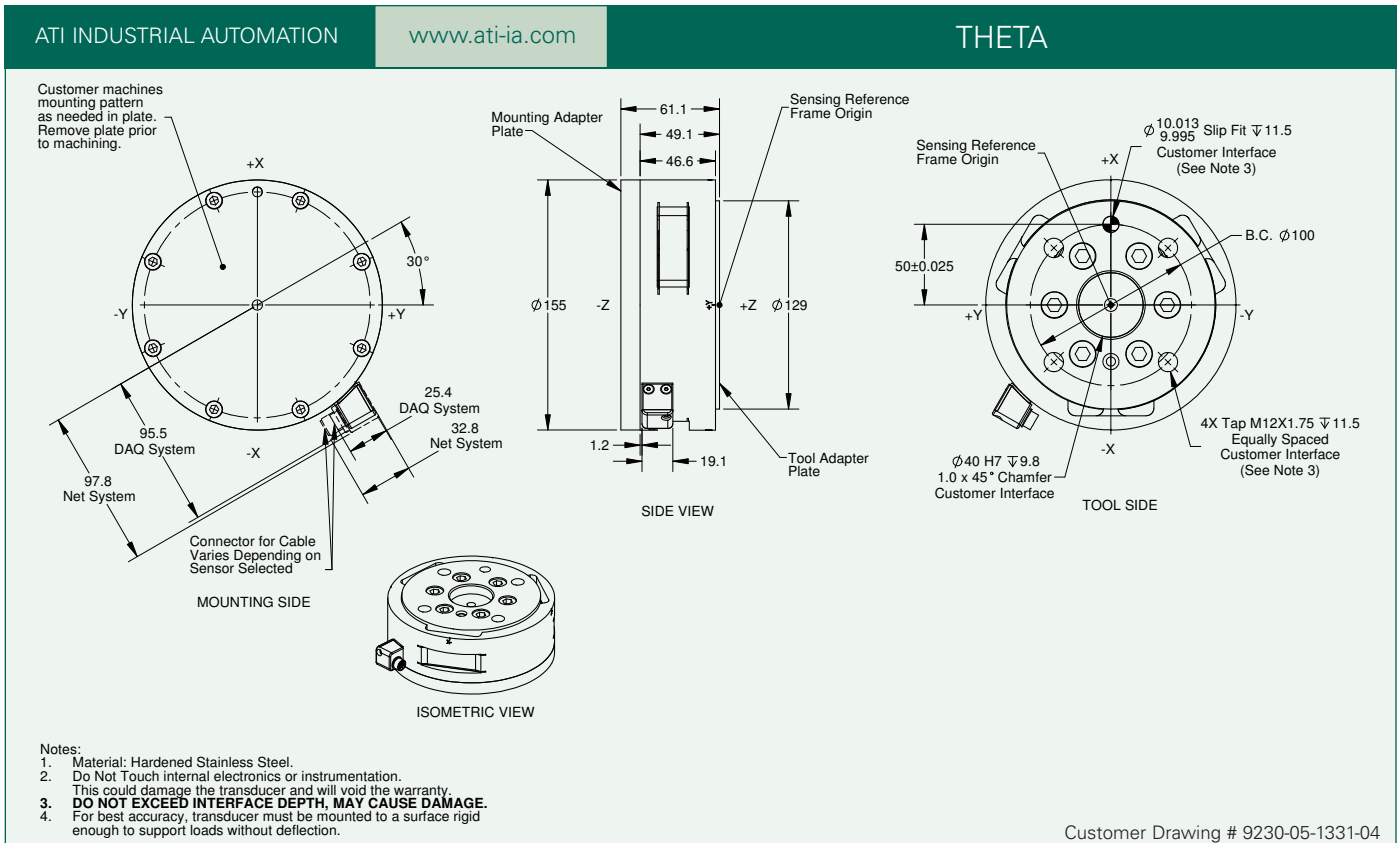

## Product Advantages

### Extremely High Strength:

- Precision machined from high-strength stainless steel.
- Maximum allowable single-axis overload values are 5.9 to 25 times rated capacities.

**High Signal-to-Noise Ratio:** Silicon strain gages provide a signal 75 times stronger than conventional foil gages. This signal is amplified, resulting in near-zero noise distortion.

**IP65 and IP68 (10m) Versions Available:** The IP65 version of the transducer provides protection against water spray. The IP68 version is for underwater environments to a maximum depth of 10 meters in fresh water. Contact ATI Industrial Automation for drawings and more information.

### Typical Applications

- Rehabilitation research
- Prosthetics research
- Humanoid robots
- Robotic assembly and machining

Note: The Omega85 does not support an on-board mux board. For Controller F/T systems, we recommend the Mini85.



**The Omega85 F/T transducer**

The transducer is made of hardened stainless steel with integral interface plates made from high-strength aircraft aluminum.

ENGLISH CALIBRATIONS	SENSING RANGES		Calibrations											
	Axes		US-105-185		US-210-370		US-420-740							
	Fx, Fy ( $\pm$ lbf)		105		210		420							
	Fz ( $\pm$ lbf)		210		420		840							
	Tx, Ty ( $\pm$ lbf-in)		185		370		740							
	Tz ( $\pm$ lbf-in)		185		370		740							
	RESOLUTION		System Type*											
	Axes		CTL		Net/DAQ		CTL		Net/DAQ					
	Fx, Fy (lbf)		1/26		1/52		5/64		5/128		5/32		5/64	
	Fz (lbf)		3/65		3/130		3/32		3/64		3/16		3/32	
Tx, Ty (lbf-in)		3/56		3/112		3/28		3/56		3/14		3/28		
Tz (lbf-in)		1/24		1/48		1/12		1/24		1/6		1/12		

METRIC CALIBRATIONS	SENSING RANGES		Calibrations											
	Axes		SI-475-20		SI-950-40		SI-1900-80							
	Fx, Fy ( $\pm$ N)		475		950		1900							
	Fz ( $\pm$ N)		950		1900		3800							
	Tx, Ty ( $\pm$ Nm)		20		40		80							
	Tz ( $\pm$ Nm)		20		40		80							
	RESOLUTION		System Type*											
	Axes		CTL		Net/DAQ		CTL		Net/DAQ					
	Fx, Fy (N)		1/7		1/14		2/7		1/7		4/7		2/7	
	Fz (N)		3/14		3/28		3/7		3/14		6/7		3/7	
Tx, Ty (Nm)		5/748		5/1496		5/374		5/748		5/187		5/374		
Tz (Nm)		7/1496		7/2992		7/748		7/1496		7/374		7/748		

\*CTL: Controller F/T System; Net: Net F/T System; DAQ: 16-bit DAQ F/T System. The resolution is typical for most applications and can be improved with filtering. Resolutions quoted are the effective resolution after dropping four counts of noise (Net/DAQ) or eight counts of noise (CTL). All sensors calibrated by ATI.

**Applied loads must be within range in each of the six axes for the F/T sensor to measure correctly** (refer to the transducer manual for complex loading information).

Single-Axis Overload	English	Metric
F <sub>xy</sub>	±2800 lbf	±13000 N
F <sub>z</sub>	±6100 lbf	±27000 N
T <sub>xy</sub>	±4400 lbf-in	±500 Nm
T <sub>z</sub>	±5400 lbf-in	±610 Nm
Stiffness (Calculated)	English	Metric
X-axis & Y-axis force (K <sub>x</sub> , K <sub>y</sub> )	4.4x10 <sup>5</sup> lb/in	7.7x10 <sup>7</sup> N/m
Z-axis force (K <sub>z</sub> )	6.8x10 <sup>5</sup> lb/in	1.2x10 <sup>8</sup> N/m
X-axis & Y-axis torque (K <sub>tx</sub> , K <sub>ty</sub> )	7.2x10 <sup>5</sup> lbf-in/rad	8.1x10 <sup>4</sup> Nm/rad
Z-axis torque (K <sub>tz</sub> )	1.2x10 <sup>6</sup> lbf-in/rad	1.3x10 <sup>5</sup> Nm/rad
Resonant Frequency (Measured)		
F <sub>x</sub> , F <sub>y</sub> , T <sub>z</sub>	2100 Hz	
F <sub>z</sub> , T <sub>x</sub> , T <sub>y</sub>	3000 Hz	
Physical Specifications	English	Metric
Weight*	1.45 lb	0.658 kg
Diameter*	3.35 in	85.1 mm
Height*	1.32 in	33.4 mm

*“ATI force sensors have become our choice sensors for force measurement in surface finishing processes. With this in mind, we are about to place our 6th order for ATI sensors in the past two years.”*

Dr. Vikram Cariapa  
 Dr. Robert Stango  
 Associate Professors of Mechanical  
 and Industrial Engineering  
 Marquette University

\*Specifications include standard interface plates and are for non-IP rated models. Diameter excludes any connector block.

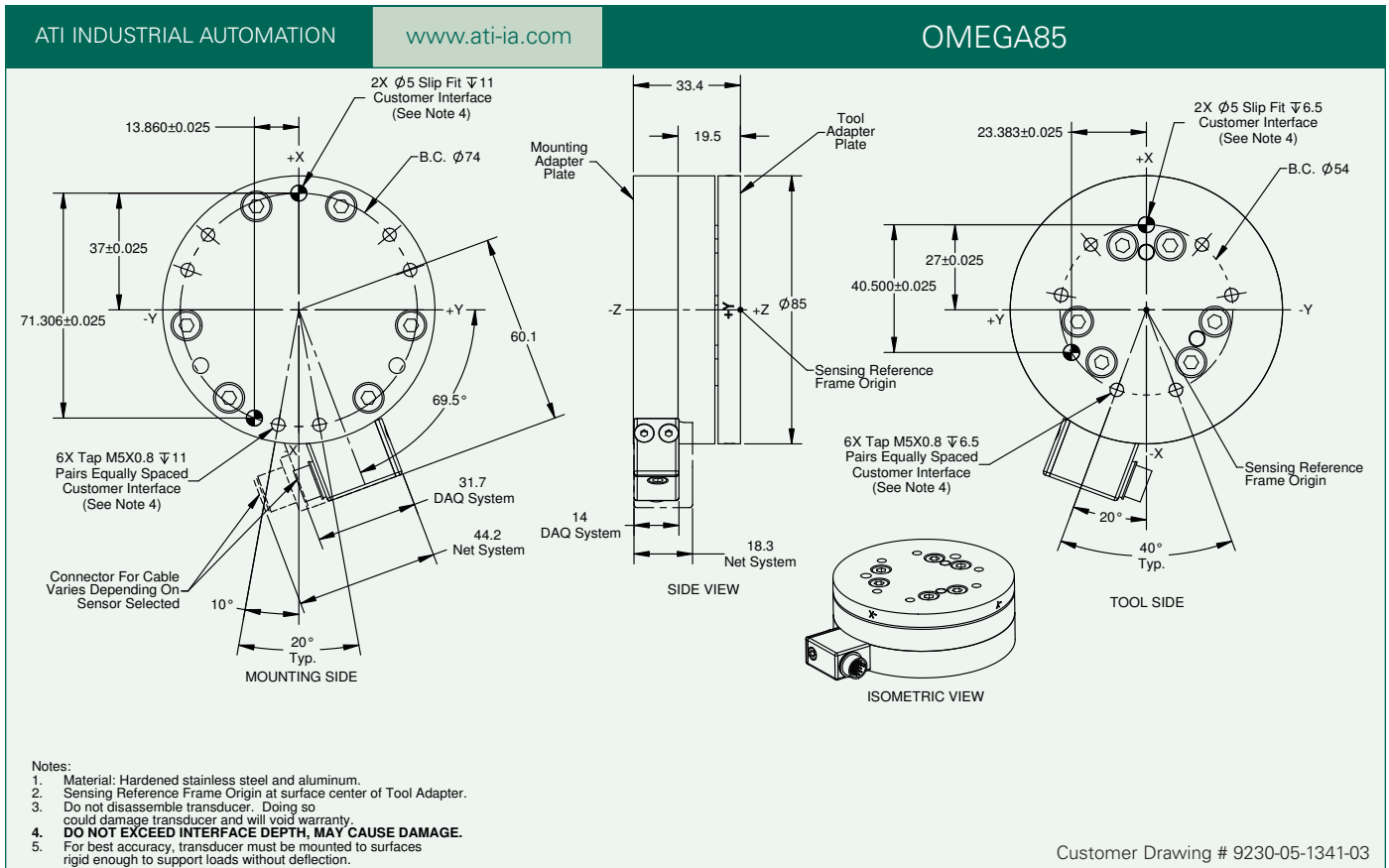

## Product Advantages

### Extremely High Strength:

- EDM wire-cut from high-yield strength stainless steel.
- Maximum allowable single-axis overload values are 4.2 to 15 times rated capacities.
- Through-hole available in some cases.

**High Signal-to-Noise Ratio:** Silicon strain gages provide a signal 75 times stronger than conventional foil gages. This signal is amplified, resulting in near-zero noise distortion.

**IP60, IP65, and IP68 (10m) Versions Available:** An IP60 version is for use in dusty environments. The IP65 version of the transducer provides protection against water spray. The IP68 version is for underwater environments to a maximum depth of 10 meters in fresh water. Contact ATI Industrial Automation for drawings and more information.

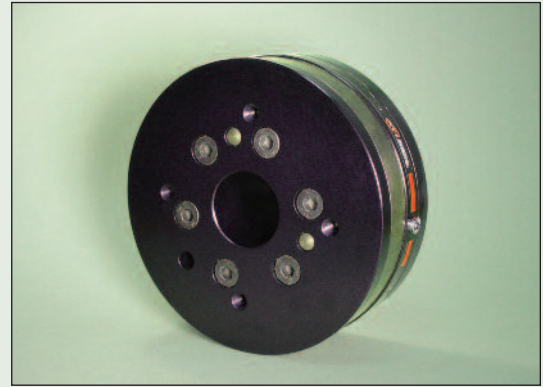

### The Omega160 F/T transducer

The transducer is made of hardened stainless steel, and the tool and mounting adapters are made of high-strength aircraft aluminum.

## Typical Applications

- Rehabilitation research
- Product testing
- Orthopedic research
- Friction stir welding
- Robotic assembly
- Telerobotics
- Part placement and removal in precision fixtures

	SENSING RANGES		Calibrations											
	Axes		US-200-1000		US-300-1800		US-600-3600							
ENGLISH CALIBRATIONS	Fx, Fy ( $\pm$ lbf)		200		300		600							
	Fz ( $\pm$ lbf)		500		875		1500							
	Tx, Ty ( $\pm$ lbf-in)		1000		1800		3600							
	Tz ( $\pm$ lbf-in)		1000		1800		3600							
	RESOLUTION		System Type*											
	Axes		CTL		Net/DAQ		CTL		Net/DAQ					
	Fx, Fy (lbf)		1/16		1/32		5/34		5/68		1/4		1/8	
	Fz (lbf)		1/8		1/16		5/17		5/34		1/2		1/4	
	Tx, Ty (lbf-in)		1/4		1/8		5/8		5/16		1		1/2	
	Tz (lbf-in)		1/4		1/8		5/8		5/16		1/2		1/4	

	SENSING RANGES		Calibrations											
	Axes		SI-1000-120		SI-1500-240		SI-2500-400							
METRIC CALIBRATIONS	Fx, Fy ( $\pm$ N)		1000		1500		2500							
	Fz ( $\pm$ N)		2500		3750		6250							
	Tx, Ty ( $\pm$ Nm)		120		240		400							
	Tz ( $\pm$ Nm)		120		240		400							
	RESOLUTION		System Type*											
	Axes		CTL		Net/DAQ		CTL		Net/DAQ					
	Fx, Fy (N)		1/2		1/4		1/2		1/4		1		1/2	
	Fz (N)		1/2		1/4		1		1/2		1 1/2		3/4	
	Tx, Ty (Nm)		1/20		1/40		1/10		1/20		1/10		1/20	
	Tz (Nm)		1/40		1/80		1/20		1/40		1/10		1/20	

\*CTL: Controller F/T System; Net: Net F/T System; DAQ: 16-bit DAQ F/T System. The resolution is typical for most applications and can be improved with filtering. Resolutions quoted are the effective resolution after dropping four counts of noise (Net/DAQ) or eight counts of noise (CTL). All sensors calibrated by ATI.

**Applied loads must be within range in each of the six axes for the F/T sensor to measure correctly** (refer to the transducer manual for complex loading information).

Single-Axis Overload	English	Metric
F <sub>xy</sub>	±3900 lbf	±18000 N
F <sub>z</sub>	±11000 lbf	±48000 N
T <sub>xy</sub>	±15000 lbf-in	±1700 Nm
T <sub>z</sub>	±17000 lbf-in	±1900 Nm
Stiffness (Calculated)	English	Metric
X-axis & Y-axis force (K <sub>x</sub> , K <sub>y</sub> )	4.0x10 <sup>5</sup> lb/in	7.0x10 <sup>7</sup> N/m
Z-axis force (K <sub>z</sub> )	6.8x10 <sup>5</sup> lb/in	1.2x10 <sup>8</sup> N/m
X-axis & Y-axis torque (K <sub>tx</sub> , K <sub>ty</sub> )	2.9x10 <sup>6</sup> lbf-in/rad	3.3x10 <sup>5</sup> Nm/rad
Z-axis torque (K <sub>tz</sub> )	4.6x10 <sup>6</sup> lbf-in/rad	5.2x10 <sup>5</sup> Nm/rad
Resonant Frequency (Non-IP rated, Measured)		
F <sub>x</sub> , F <sub>y</sub> , T <sub>z</sub>	1300 Hz	
F <sub>z</sub> , T <sub>x</sub> , T <sub>y</sub>	1000 Hz	
Physical Specifications	English	Metric
Weight*	6.0 lb	2.72 kg
Diameter*	6.16 in	156.5 mm
Height*	2.2 in	55.9 mm

\*Specifications include standard interface plates and are for non-IP rated models. Diameter excludes any connector block.

ATI INDUSTRIAL AUTOMATION
www.ati-ia.com
OMEGA160

Customer machines mounting pattern in plate as needed. Remove plate prior to machining.

Mounting Adapter Plate

Tool Adapter Plate

φ 40 H7 T10 Customer Interface (See Note 3)

φ 156.5

φ 10 Slip Fit T10 Customer Interface (See Note 3)

B.C. φ 100

50±0.013

Sensing Reference Frame Origin

(4) Tap M10 x 1.5 T10 Equally Spaced Customer Interface (See Note 3)

TOOL SIDE

ISOMETRIC VIEW

Notes:

1. Material: Hardened Stainless Steel and Aluminum
2. Do not touch internal electronics or instrumentation. This could damage the transducer and will void the warranty.
3. **DO NOT EXCEED INTERFACE DEPTH, MAY CAUSE DAMAGE.**
4. For best accuracy, transducer must be mounted to surfaces rigid enough to support loads without deflection.

Customer Drawing # 9230-05-1131-09

## Product Advantages

### Extremely High Strength:

- EDM wire-cut from high-yield strength stainless steel.
- Maximum allowable single-axis overload values are 4.8 to 19 times rated capacities.
- Through-hole available in some cases.

**High Signal-to-Noise Ratio:** Silicon strain gages provide a signal 75 times stronger than conventional foil gages. This signal is amplified, resulting in near-zero noise distortion.

**IP60, IP65, and IP68 (10m) Versions Available:** An IP60 version is for use in dusty environments. The IP65 version of the transducer provides protection against water spray. The IP68 version is for underwater environments to a maximum depth of 10 meters in fresh water. Contact ATI Industrial Automation for drawings and more information.

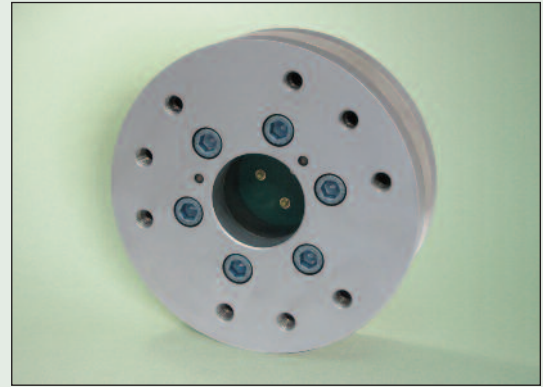

### The Omega191 F/T transducer

The transducer is made of hardened stainless steel, and the tool and mounting adapters are made of high-strength stainless steel.

## Typical Applications

- Product testing
- Telerobotics
- Friction stir welding
- Force feedback
- Part placement and removal in precision fixtures

	SENSING RANGES		Calibrations										
	Axes		US-400-3000		US-800-6000		US-1600-12000						
ENGLISH CALIBRATIONS	Fx, Fy ( $\pm$ lbf)		400		800		1600						
	Fz ( $\pm$ lbf)		1000		2000		4000						
	Tx, Ty ( $\pm$ lbf-in)		3000		6000		12000						
	Tz ( $\pm$ lbf-in)		3000		6000		12000						
	RESOLUTION		System Type*										
Axes		CTL		Net/DAQ		CTL		Net/DAQ					
Fx, Fy (lbf)		5/32		5/64		5/16		5/32		5/8		5/16	
Fz (lbf)		5/16		5/32		5/8		5/16		1 1/4		5/8	
Tx, Ty (lbf-in)		15/16		15/32		1 7/8		15/16		3 3/4		1 7/8	
Tz (lbf-in)		5/8		5/16		1 1/4		5/8		2 1/2		1 1/4	

	SENSING RANGES		Calibrations										
	Axes		SI-1800-350		SI-3600-700		SI-7200-1400						
METRIC CALIBRATIONS	Fx, Fy ( $\pm$ N)		1800		3600		7200						
	Fz ( $\pm$ N)		4500		9000		18000						
	Tx, Ty ( $\pm$ Nm)		350		700		1400						
	Tz ( $\pm$ Nm)		350		700		1400						
	RESOLUTION		System Type*										
Axes		CTL		Net/DAQ		CTL		Net/DAQ					
Fx, Fy (N)		3/4		3/8		1 1/2		3/4		3		1 1/2	
Fz (N)		1 1/2		3/4		3		1 1/2		6		3	
Tx, Ty (Nm)		5/48		5/96		5/24		5/48		5/12		5/24	
Tz (Nm)		5/72		5/144		5/36		5/72		5/18		5/36	

\*CTL: Controller F/T System; Net: Net F/T System; DAQ: 16-bit DAQ F/T System. The resolution is typical for most applications and can be improved with filtering. Resolutions quoted are the effective resolution after dropping four counts of noise (Net/DAQ) or eight counts of noise (CTL). All sensors calibrated by ATI.

Applied loads must be within range in each of the six axes for the F/T sensor to measure correctly (refer to the transducer manual for complex loading information).

Single-Axis Overload	English	Metric
F <sub>xy</sub>	±8000 lbf	±36000 N
F <sub>z</sub>	±25000 lbf	±110000 N
T <sub>xy</sub>	±60000 lbf-in	±6800 Nm
T <sub>z</sub>	±60000 lbf-in	±6800 Nm
Stiffness (Calculated)	English	Metric
X-axis & Y-axis force (K <sub>x</sub> , K <sub>y</sub> )	1.4x10 <sup>6</sup> lb/in	2.4x10 <sup>8</sup> N/m
Z-axis force (K <sub>z</sub> )	2.1x10 <sup>6</sup> lb/in	3.6x10 <sup>8</sup> N/m
X-axis & Y-axis torque (K <sub>tx</sub> , K <sub>ty</sub> )	1.4x10 <sup>7</sup> lbf-in/rad	1.5x10 <sup>6</sup> Nm/rad
Z-axis torque (K <sub>tz</sub> )	2.8x10 <sup>7</sup> lbf-in/rad	3.2x10 <sup>6</sup> Nm/rad
Physical Specifications	English	Metric
Weight*	20.8 lb	9.41 kg
Diameter*	7.48 in	190 mm
Height*	2.52 in	64.0 mm

\*Specifications include standard interface plates and are for non-IP rated models. Diameter excludes any connector block.

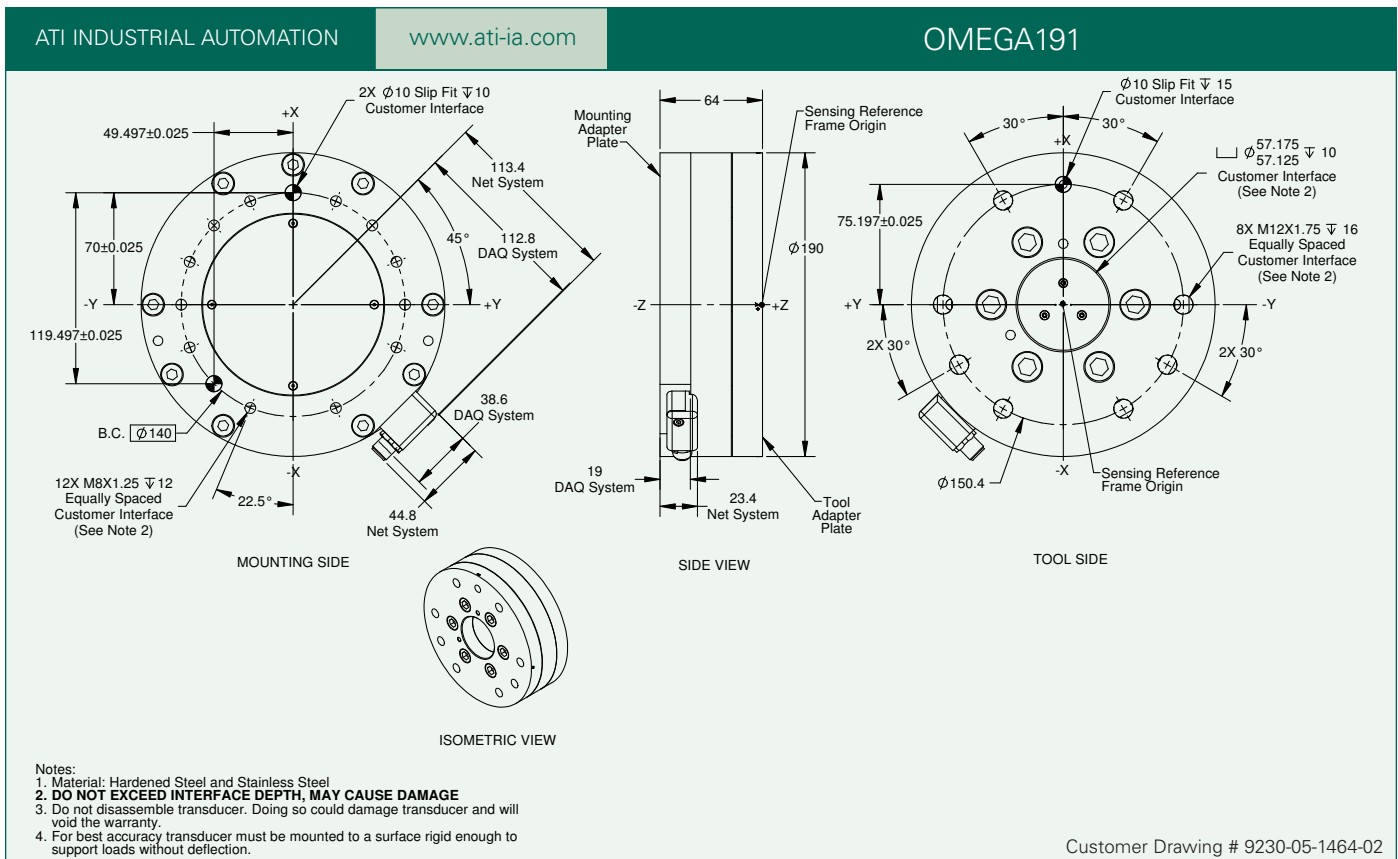

## Product Advantages

### Extremely High Strength:

- EDM wire-cut from high-yield strength stainless steel.
- Maximum allowable single-axis overload values are 10 to 40 times rated capacities.

**High Signal-to-Noise Ratio:** Silicon strain gages provide a signal 75 times stronger than conventional foil gages. This signal is amplified, resulting in near-zero noise distortion.

**IP60 (Standard), IP65, and IP68 (10m) Versions Available:** An IP60 version is for use in dusty environments and is standard on this model. An IP65 version of the transducer provides protection against water spray. The IP68 version is for underwater environments to a maximum depth of 10 meters in fresh water. Contact ATI Industrial Automation for drawings and more information.

## Typical Applications

- Product testing
- Telerobotics
- Force feedback
- Part placement and removal in precision fixtures

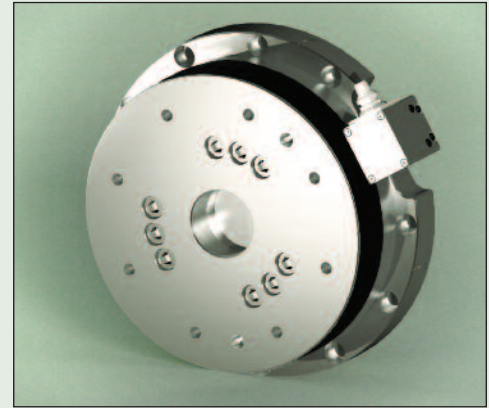

### The Omega250 F/T transducer

The transducer is made of hardened stainless steel, and the tool and mounting adapters are made of high-strength stainless steel.

ENGLISH CALIBRATIONS	SENSING RANGES		Calibrations											
	Axes		US-900-4500		US-1800-9000		US-3600-18000							
	Fx, Fy (±lbf)		900		1800		3600							
	Fz (±lbf)		1800		3600		7200							
	Tx, Ty (±lbf-in)		4500		9000		18000							
	Tz (±lbf-in)		4500		9000		18000							
	RESOLUTION		System Type*											
	Axes		CTL		Net/DAQ		CTL		Net/DAQ					
	Fx, Fy (lbf)		1		1/2		2		1		5		2	
	Fz (lbf)		1		1/2		2		1		5		2	
Tx, Ty (lbf-in)		2		1		5		2		10		5		
Tz (lbf-in)		2		1		5		2		10		5		

METRIC CALIBRATIONS	SENSING RANGES		Calibrations											
	Axes		SI-4000-500		SI-8000-1000		SI-16000-2000							
	Fx, Fy (±N)		4000		8000		16000							
	Fz (±N)		8000		16000		32000							
	Tx, Ty (±Nm)		500		1000		2000							
	Tz (±Nm)		500		1000		2000							
	RESOLUTION		System Type*											
	Axes		CTL		Net/DAQ		CTL		Net/DAQ					
	Fx, Fy (N)		2		1		4		2		8		4	
	Fz (N)		4		2		8		4		16		8	
Tx, Ty (Nm)		1/4		1/8		1/2		1/4		1		1/2		
Tz (Nm)		1/4		1/8		1/2		1/4		1		1/2		

\*CTL: Controller F/T System; Net: Net F/T System; DAQ: 16-bit DAQ F/T System. The resolution is typical for most applications and can be improved with filtering. Resolutions quoted are the effective resolution after dropping four counts of noise (Net/DAQ) or eight counts of noise (CTL). All sensors calibrated by ATI.

**Applied loads must be within range in each of the six axes for the F/T sensor to measure correctly** (refer to the transducer manual for complex loading information).



Single-Axis Overload	English	Metric
Fxy	±37000 lbf	±160000 N
Fz	±74000 lbf	±330000 N
Txy	±180000 lbf-in	±21000 Nm
Tz	±220000 lbf-in	±25000 Nm
Stiffness (Calculated)	English	Metric
X-axis & Y-axis force (Kx, Ky)	2.4x10 <sup>6</sup> lb/in	4.2x10 <sup>8</sup> N/m
Z-axis force (Kz)	3.2x10 <sup>6</sup> lb/in	5.6x10 <sup>8</sup> N/m
X-axis & Y-axis torque (Ktx, Kty)	2.7x10 <sup>7</sup> lbf-in/rad	3.0x10 <sup>6</sup> Nm/rad
Z-axis torque (Ktz)	5.5x10 <sup>7</sup> lbf-in/rad	6.2x10 <sup>6</sup> Nm/rad
Resonant Frequency (Non-IP rated, Measured)		
Fx, Fy, Tz	780 Hz	
Fz, Tx, Ty	770 Hz	
Physical Specifications	English	Metric
Weight*	70 lb	31.8 kg
Diameter*	11.6 in, 2.12 in	295 mm, 54 mm
Height*	3.74 in	94.9 mm

\*Specifications include standard interface plates. Diameter excludes any connector block.

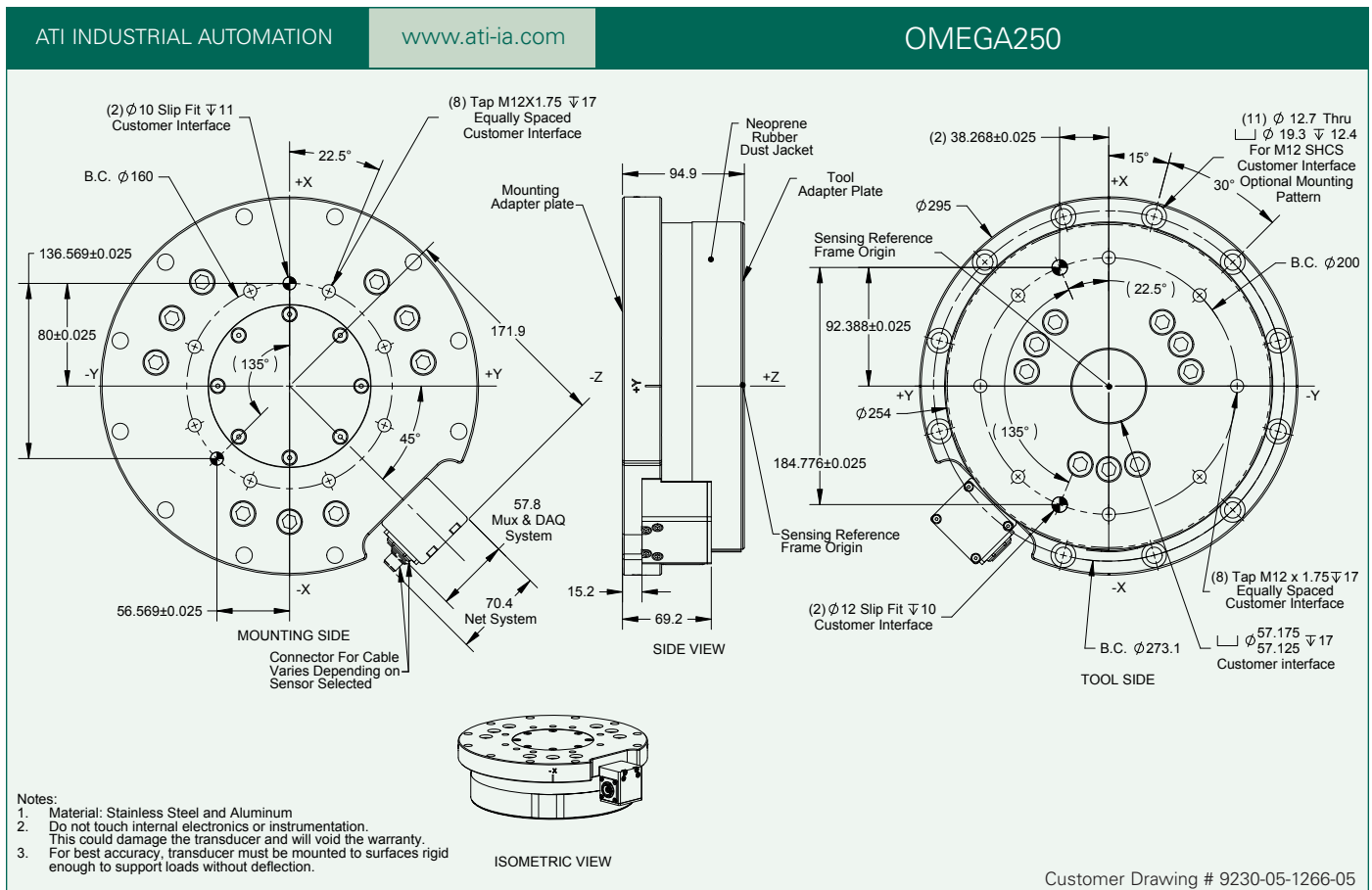

## Product Advantages

### Extremely High Strength:

- EDM wire-cut from high-yield strength stainless steel.
- Maximum allowable single-axis overload values are 5.3 to 21 times rated capacities.

**High Signal-to-Noise Ratio:** Silicon strain gages provide a signal 75 times stronger than conventional foil gages. This signal is amplified, resulting in near-zero noise distortion.

**IP65 Version Available:** The IP65 version of the transducer provides protection against water spray. Contact ATI Industrial Automation for drawings and more information.

### Typical Applications

- Product testing
- Force feedback
- Telerobotics



### The Omega331 F/T transducer

The transducer is made of hardened stainless steel, and the tool and mounting adapters are made of high-strength stainless steel.

ENGLISH CALIBRATIONS	SENSING RANGES		Calibrations					
	Axes		US-2250-13000		US-4500-26000		US-9000-52000	
	Fx, Fy (±lbf)		2250		4500		9000	
	Fz (±lbf)		5250		10500		21000	
	Tx, Ty (±lbf-in)		13000		26000		52000	
	Tz (±lbf-in)		13000		26000		52000	
ENGLISH CALIBRATIONS	RESOLUTION		System Type*					
	Axes		CTL		Net/DAQ		Net/DAQ	
	Fx, Fy (lbf)		1		1/2		2	
	Fz (lbf)		2		1		4	
	Tx, Ty (lbf-in)		7 1/2		3 3/4		15	
	Tz (lbf-in)		3 3/4		1 7/8		7 1/2	

METRIC CALIBRATIONS	SENSING RANGES		Calibrations					
	Axes		SI-10000-1500		SI-20000-3000		SI-40000-6000	
	Fx, Fy (±kN)		10		20		40	
	Fz (±kN)		22		44		88	
	Tx, Ty (±kNm)		1.5		3		6	
	Tz (±kNm)		1.5		3		6	
METRIC CALIBRATIONS	RESOLUTION		System Type*					
	Axes		CTL		Net/DAQ		Net/DAQ	
	Fx, Fy (kN)		1/240		1/480		1/120	
	Fz (kN)		1/120		1/240		1/60	
	Tx, Ty (kNm)		3/4000		3/8000		3/2000	
	Tz (kNm)		3/8000		3/16000		3/4000	

\*CTL: Controller F/T System; Net: Net F/T System; DAQ: 16-bit DAQ F/T System. The resolution is typical for most applications and can be improved with filtering. Resolutions quoted are the effective resolution after dropping four counts of noise (Net/DAQ) or eight counts of noise (CTL). All sensors calibrated by ATI.

**Applied loads must be within range in each of the six axes for the F/T sensor to measure correctly** (refer to the transducer manual for complex loading information).

Single-Axis Overload	English	Metric
F <sub>xy</sub>	±58000 lbf	±260000 N
F <sub>z</sub>	±120000 lbf	±520000 N
T <sub>xy</sub>	±280000 lbf-in	±32000 Nm
T <sub>z</sub>	±410000 lbf-in	±46000 Nm
Stiffness (Calculated)	English	Metric
X-axis & Y-axis force (K <sub>x</sub> , K <sub>y</sub> )	6.9x10 <sup>6</sup> lb/in	1.2x10 <sup>9</sup> N/m
Z-axis force (K <sub>z</sub> )	7.3x10 <sup>6</sup> lb/in	1.3x10 <sup>9</sup> N/m
X-axis & Y-axis torque (K <sub>tx</sub> , K <sub>ty</sub> )	8.1x10 <sup>7</sup> lbf-in/rad	9.2x10 <sup>6</sup> Nm/rad
Z-axis torque (K <sub>tz</sub> )	2.1x10 <sup>8</sup> lbf-in/rad	2.4x10 <sup>7</sup> Nm/rad
Physical Specifications	English	Metric
Weight*	104 lb	47 kg
Diameter (OD,ID)*	13 in, 4 in	330 mm, 102mm
Height*	4.22 in	107 mm

\*Specifications include standard interface plates. Diameter excludes any connector block.

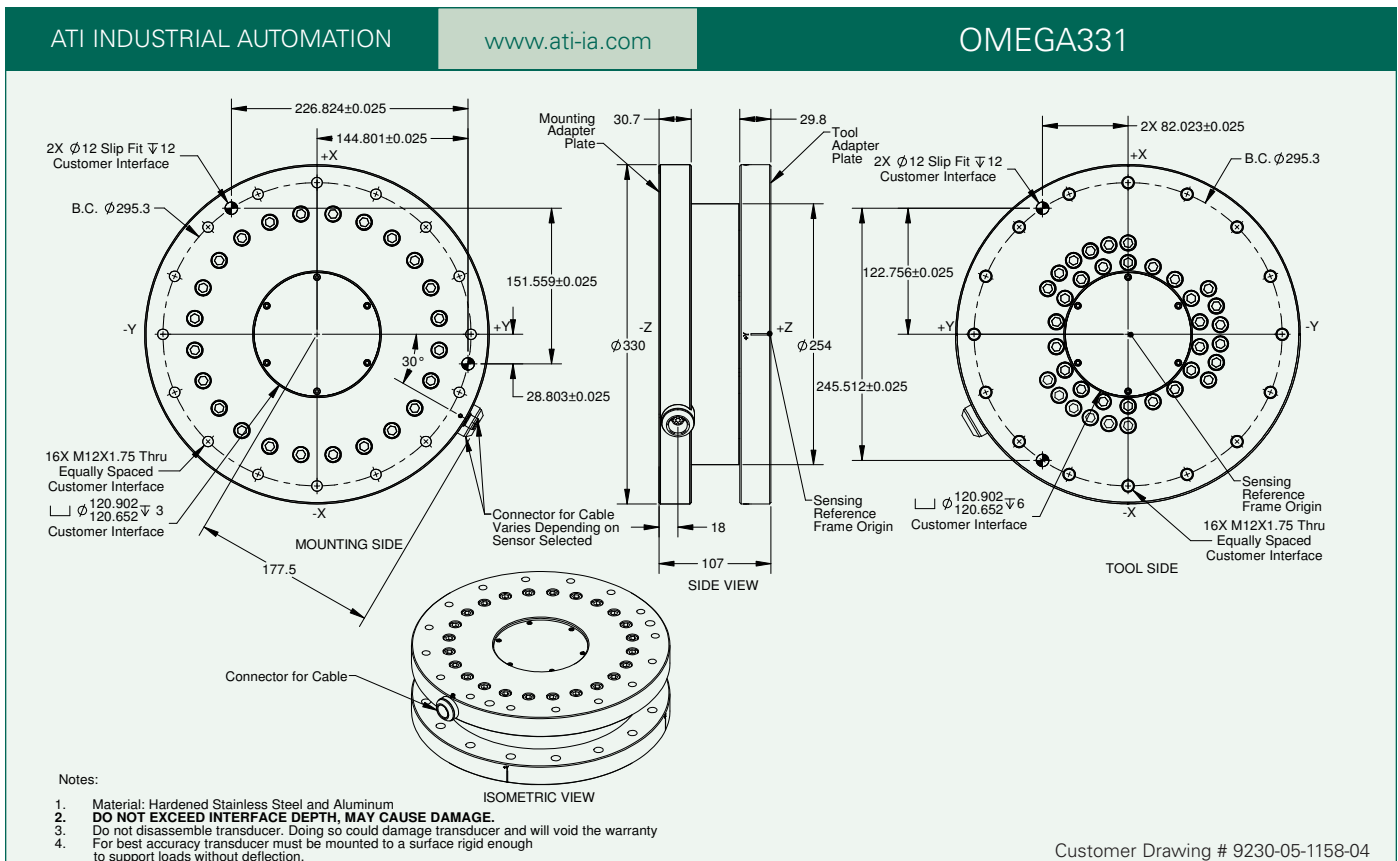

## Other ATI Products

### Robotic/Automatic Tool Changer

A high-precision rugged device that automatically changes tooling. Patented fail-safe locking mechanism uses No-Touch Locking™ technology, allowing plate separation when locking.

### Robotic/Automatic Tool Changers for Heavy Automation

This series of modular Tool Changers are designed specifically for high-payload and high-moment applications. **Utility Modules** to pass air, fluid, and electrical signals are also available for use in non-tool changer applications. Useful for processes requiring repeated connection/disconnection of utilities.

### Utility Couplers

Quickly connects utilities such as air and electrical signals in docking and fixturing applications. Features a unique compliance mechanism that compensates for severe tooling misalignments. The modular body design is capable of mounting any of ATI's standard add-on utility modules.

### Manual Tool Changers

Cost-effective solution for quickly changing tools by hand. Compact design combines high strength and excellent repeatability while preventing loosening.

### Robotic Collision Sensor

Designed to prevent damage to robotic end-effectors resulting from robot crashes. Features include: Automatic reset, high-repeatability, and large moment rotation.

### Robotic & CNC Deburring Tools

These air-driven robotic tools cover a wide variety of automated deburring and finishing applications with fast cycle times and clean, accurate cuts. The Radially-Compliant Deburring Tool is designed for removal of parting lines and flash. The Axially-Compliant Deburring Tool is specially designed for edge deburring and chamfering. The Axially-Compliant Finishing Tool is designed for material finishing operations on aluminum, plastic, steel, and more.

### Automated Assembly Alignment Device

An insertion device using Remote Center Compliance technology that helps assembly machines automatically align close-fitting parts, preventing jamming and galling.

## Company Profile

ATI Industrial Automation is a world-leading developer of Automatic Tool Changers, Multi-Axis Force/Torque Sensing Systems, Utility Couplers, Robotic Collision Sensors, Robotic Deburring Tools, and Compliance Devices. Our products are found in thousands of successful applications around the world.

Since 1989, our engineers have been developing cost-effective, state-of-the-art products and solutions to improve manufacturing productivity.

Our Mission is to provide customers around the world with high-quality robotic peripheral devices, tooling and sensors that enhance customer profitability by increasing the effectiveness, flexibility, safety and productivity of their automation applications. We accomplish this through continuous improvement of existing products, product customization and new product innovation.

Our engineering-centric staff focuses on providing customer solutions to robotic, automation and sensing applications.

## Our Quality Policy

ATI Industrial Automation strives to provide customer satisfaction through continual improvement of on-time delivery, quality and reliability, and a constant focus on innovation and profitability.



*Engineered Products for Robotic Productivity*

1031 Goodworth Drive  
Apex, NC 27539 USA

+1 919.772.0115  
+1 919.772.8259 fax  
E-mail: [info@ati-ia.com](mailto:info@ati-ia.com)  
[www.ati-ia.com](http://www.ati-ia.com)