



## Tool Stand Large (TSL)

Manual



Document #: 9610-20-1058

*Engineered Products for Robotic Productivity*

Pinnacle Park • 1031 Goodworth Drive • Apex, NC 27539 USA • Tel: +1 919-772-0115 • Fax: +1 919-772-8259 • [www.ati-ia.com](http://www.ati-ia.com)

## Foreword

Please contact ATI Industrial Automation with any questions concerning a particular model.



**CAUTION:** This manual describes the function, application, and safety considerations of this product. This manual must be read and understood before any attempt is made to install or operate the product, otherwise damage to the product or unsafe conditions may occur.

Information contained in this document is the property of ATI Industrial Automation, Inc (ATI) and shall not be reproduced in whole or in part without prior written approval of ATI. The information herein is subject to change without notice. This manual is periodically revised to reflect and incorporate changes made to the product.

The information contained herein is confidential and reserved exclusively for the customers and authorized agents of ATI Industrial Automation and may not be divulged to any third party without prior written consent from ATI. No warranty including implied warranties is made with regard to accuracy of this document or fitness of this device for a particular application. ATI Industrial Automation shall not be liable for any errors contained in this document or for any incidental or consequential damages caused thereby. ATI Industrial Automation reserves the right to make changes to this manual at any time without prior notice.

ATI assumes no responsibility for any errors or omissions in this document.

Copyright © (2024) by ATI Industrial Automation. All rights reserved.

For terms and conditions of sale, refer to the [website](#) or contact an ATI representative.

Contact information:

Sale, Service and Information about ATI products:

**ATI Industrial Automation**

1031 Goodworth Drive  
Apex, NC 27539 USA  
www.ati-ia.com  
Tel: +1 919-772-0115  
Fax: +1 919-772-8259

**Application Engineering**

E-mail: [Applications.Engineers@novanta.com](mailto:Applications.Engineers@novanta.com)

24/7 Support: +1 855 ATI-IA 00 (+1 855-284-4200)

# Table of Contents

<b>Foreword</b> .....	<b>2</b>
<b>Glossary</b> .....	<b>5</b>
<b>1. Safety</b> .....	<b>6</b>
<b>1.1 Explanation of Notifications</b> .....	<b>6</b>
<b>1.2 General Safety Guidelines</b> .....	<b>6</b>
<b>1.3 Safety Precautions</b> .....	<b>7</b>
<b>2. Product Overview</b> .....	<b>8</b>
<b>2.1 TSL System with Pin and Bushing Style Mounting</b> .....	<b>8</b>
2.1.1 Post Module with Pin and Bushing Style Mounting .....	9
2.1.2 Pin and Bushing Mounting Module.....	9
2.1.3 Tooling Interface Plates .....	10
2.1.4 Sensor Modules .....	10
2.1.5 Proximity Sensors .....	10
2.1.6 TSI Assemblies for Pin and Bushing Modules.....	11
<b>2.2 TSL System with Hook and Hanger Style Mounting</b> .....	<b>12</b>
2.2.1 Post Module with Hook and Hanger Style Mounting .....	13
2.2.2 Hook Mounting Modules.....	13
2.2.3 Vertical Hook Tool Interface Plate Assembly .....	13
2.2.4 Horizontal Tool Hook Modules.....	14
2.2.5 Proximity Sensors .....	14
2.2.6 TSI Systems for Hook and Hanger Modules .....	15
<b>2.3 Optional TSL System Components</b> .....	<b>16</b>
2.3.1 Horizontal Extension Modules.....	16
2.3.2 Components to Configure a Custom TSI Assembly .....	16
2.3.3 DSA (Debris Shield Actuator) .....	17
2.3.4 Debris Shield and Shield Arm.....	18
2.3.5 Post-Mounted Tool Support.....	18
<b>2.4 How to Determine a Tool Stand Configuration</b> .....	<b>19</b>
2.4.1 Configuration of a TSL System with Pin and Bushing Module .....	20
2.4.2 Configuration of a TSL System with a Hook and Hanger Module .....	21
2.4.3 Configuration of a TSL System with TSI Switch on the Master .....	23
<b>3. Installation</b> .....	<b>24</b>
<b>3.1 Installing the Post Module, Pin and Bushing or Hook and Hanger Module</b> .....	<b>24</b>
<b>3.2 Hook Arm Installation</b> .....	<b>26</b>
<b>3.3 Install a Sensor Module to a Pin and Bushing Module</b> .....	<b>27</b>
3.3.1 Dual Sensor Module Installation.....	27

<b>3.4</b>	<b>Install a Proximity Sensor to a Hook Module</b> .....	<b>28</b>
<b>3.5</b>	<b>Installation of a Tool Stand Interlock (TSI) Switch Assembly</b> .....	<b>29</b>
3.5.1	Install a TSI Switch Assembly on a Pin and Bushing Module and Horizontal Tool Interface Plate .....	30
3.5.2	Installation of a TSI Switch Assembly to a Pin and Bushing Module and Vertical Tooling Interface Plate .....	31
3.5.3	Pin and Bushing Module: Installation of a Non-Contact Euchner TSI Switch and Actuator .....	32
3.5.4	Pin and Bushing Module: Installation of a Sipha TSI Switch and Actuator.....	33
3.5.5	Hook Module with Vertical Tooling Hook Plate or Tool Hook Modules (Limit Switch).....	35
3.5.6	Hook Module with Vertical Tooling Hook Plate or Tool Hook Modules (Non-Contact Euchner Actuator and Switch) .....	36
3.5.7	Hook Module with Vertical Tooling Hook Plate or Tool Hook Modules (Sipha Switch) .....	38
<b>3.6</b>	<b>Installing a Debris Shield</b> .....	<b>39</b>
<b>3.7</b>	<b>Installing a Post-mounted Tool Support and Post Support Roller</b> .....	<b>43</b>
<b>4.</b>	<b>Operation</b> .....	<b>45</b>
4.1	Tips for Programming the Tool Changer.....	45
4.2	TSL System with Pin and Bushing Style Mounting Operation .....	45
4.3	TSL System with Hook Style Mounting Operation .....	46
<b>5.</b>	<b>Maintenance</b> .....	<b>47</b>
5.1	Preventative Maintenance .....	47
5.1.1	All TSL Systems .....	47
5.1.2	TSL Systems with Pin and Bushing Style Mounting Modules .....	47
5.1.3	TSL Systems with Hook and Hanger Style Mounting Modules .....	48
5.1.4	Preventive Maintenance Procedures .....	48
5.1.4.1	Clean, Lubricate, and Replace Alignment Pins and Bushings.....	48
<b>6.</b>	<b>Troubleshooting</b> .....	<b>52</b>
<b>7.</b>	<b>Serviceable Parts</b> .....	<b>53</b>
7.1	Part Number Cross Reference .....	53
7.1.1	TSL Systems with Pin and Bushing Style Mounting.....	53
7.1.2	TSL Systems with Hook and Hanger Style Mounting.....	53
<b>8.</b>	<b>Specifications</b> .....	<b>54</b>
8.1	Components for TSL Systems with Pin and Bushing Style Mounting.....	54
8.2	Components for TSL Systems with Hook and Hanger Style Mounting .....	54
8.3	Debris Shield Components for TSL Systems .....	55
8.3.1	Debris Shield Actuators Specifications.....	55
8.4	TSI Euchner Contact Switch Electrical Specifications .....	55
<b>9.</b>	<b>Drawings</b> .....	<b>55</b>

## Glossary

Term	Definition
Alignment Pin	Attaches to the interface plate assembly and mounting module to support and locate the tooling in the Tool Stand.
Debris Shield	Cover that protects against dirt and debris build up on the Tool plate assembly and modules..
Debris Shield Actuator	Pneumatically actuated device that moves the debris shield over the Tool Changer for protection and removes the shield for Tool pickup.
End-Effector	A tool or other device attached to the robot arm in order to perform a task.
Euchner Actuator or Sensor	An electrical proximity device that is used in a TSI system.
Hook and Hanger Mounting	A Tool Stand that uses mounting modules with hangers to support and accurately locate the Tool plate and customer tooling.
Horizontal Extension Modules	Provides more tool clearance for the customer tooling than the standard TSL post module
Jog	The action of running an assembly process or robot at a slower pace than normal operational speed.
Master plate	The half of the Tool Changer that is mounted to an interface plate or the robot.
Modules	Optional assemblies that can be installed to the Master and Tool plates to enhance the capabilities of the Tool Changer. For example: fluid/air, electrical, control/signal, servo, high-current modules.
Mounting Module	Provides a mount on the Tool Stand for the tooling interface plate or can mount the Tool plate directly for some specific models.
Pin and Bushing Mounting	A Tool Stand configuration that uses mounting modules with alignment pins and a bushing to support and accurately locate the Tool plate and customer tooling.
Post Module	A welded steel vertical post to which (1) or more mounting modules are installed.
Post-mounted Tool Support	A fixture that attaches to the post module to support unbalanced customer tooling.
Proximity Sensor	Provides a signal indicating the tool is located in the Tool Stand.
Rigid Mounting Modules	A feature on the TSL that couples to the tooling interface plate and provides a fixed position when Tool is dropped off or picked up from the TSL system.
Sensor Modules	Provides a mount on the Tool Stand for the proximity sensor.
Sipha Actuator or Sensor	A proximity sensor type switch used in the tool stand interlock system.
Tool Hook Modules	Tooling fixture that utilizes steel hooks to support the Tool plate and customer tooling on the Tool Stand.
Tooling Interface plate	A machined plate that adapts the Tool plate to an end-effector and provides mounting features for a Tool Stand.
Tool plate	The half of the Tool Changer that is mounted to tooling interface plate and/or the customer-supplied tooling.
Tool Stand Interlock (TSI)	A system that detects that the Tool plate is safely placed on the Tool Stand. The Tool Stand has a TSI switch assembly that is used congruently with the TSI connector on the Tool control module. For more information about control modules, refer to the applicable control module manual.
Trip Dog	A mechanical trip for a TSI switch that is mounted to the Tool Stand.
TSI Switch Assembly	An assembly that includes a TSI switch and either a mechanical (trip dog) or electrical actuator that is mounted to the Tool Stand.
Tool Stand Large (TSL) system	Tool Stand Large is a custom configuration provided by ATI for holding the Tool plate and attached customer tooling when not in use.
Vertical Tooling Interface Plate	A machined plate with a vertical surface that adapts the customer tooling and provides mounting features for a Tool Stand.

## 1. Safety

The safety section describes general safety guidelines to be followed with this product, explanations of the notifications found in this manual, and safety precautions that apply to the product. Product specific notifications are imbedded within the sections of this manual (where they apply).

### 1.1 Explanation of Notifications

These notifications are used in all of ATI manuals and are not specific to this product. The user should heed all notifications from the robot manufacturer and/or the manufacturers of other components used in the installation.



**DANGER:** Notification of information or instructions that if not followed will result in death or serious injury. The notification provides information about the nature of the hazardous situation, the consequences of not avoiding the hazard, and the method for avoiding the situation.



**WARNING:** Notification of information or instructions that if not followed could result in death or serious injury. The notification provides information about the nature of the hazardous situation, the consequences of not avoiding the hazard, and the method for avoiding the situation.



**CAUTION:** Notification of information or instructions that if not followed could result in moderate injury or will cause damage to equipment. The notification provides information about the nature of the hazardous situation, the consequences of not avoiding the hazard, and the method for avoiding the situation.

**NOTICE:** Notification of specific information or instructions about maintaining, operating, installing, or setting up the product that if not followed could result in damage to equipment. The notification can emphasize, but is not limited to: specific grease types, best operating practices, and maintenance tips.

### 1.2 General Safety Guidelines

This system is intended for use in the industrial applications for tool changing and storage and therefore requires the use of a Tool Changer.

Prior to purchase and installation, the customer should verify that the Tool Changer selected is rated for the maximum loads and moments expected during operation. Refer to the applicable Tool Changer manual or contact ATI for assistance.



**WARNING:** The customer is responsible for ensuring that the area between the Tool and the Tool Stand is clear of foreign objects during tool drop-off. Failure to do so may result in serious injury to personnel.



**WARNING:** The gap between the Master and Tool sides is a pinch point. All personnel should be prevented from placing any part of their body or clothing in the gap, especially during actuation of the tool hanger mechanism.

### 1.3 Safety Precautions



**WARNING:** Do not perform maintenance or repair(s) on the Tool Changer or modules unless the Tool is safely supported or placed in the tool stand, all energized circuits (for example: electrical, air, water, etc.) are turned off, pressurized connections are purged and power is discharged from circuits in accordance with the customer specific safety practices and policies. Injury or equipment damage can occur with the Tool not placed and energized circuits on. Place the Tool in the tool stand, turn off and discharge all energized circuits, purge all pressurized connections, and verify all circuits are de-energized before performing maintenance or repair(s) on the Tool Changer or modules.



**WARNING:** During operation, the area between the Master and Tool must be kept clear. Failure to keep area clear will result in damage to Tool Changer, modules, or end-of-arm tooling and could cause injury to personnel.



**CAUTION:** This system is only to be used for intended applications and applications approved by the manufacturer.

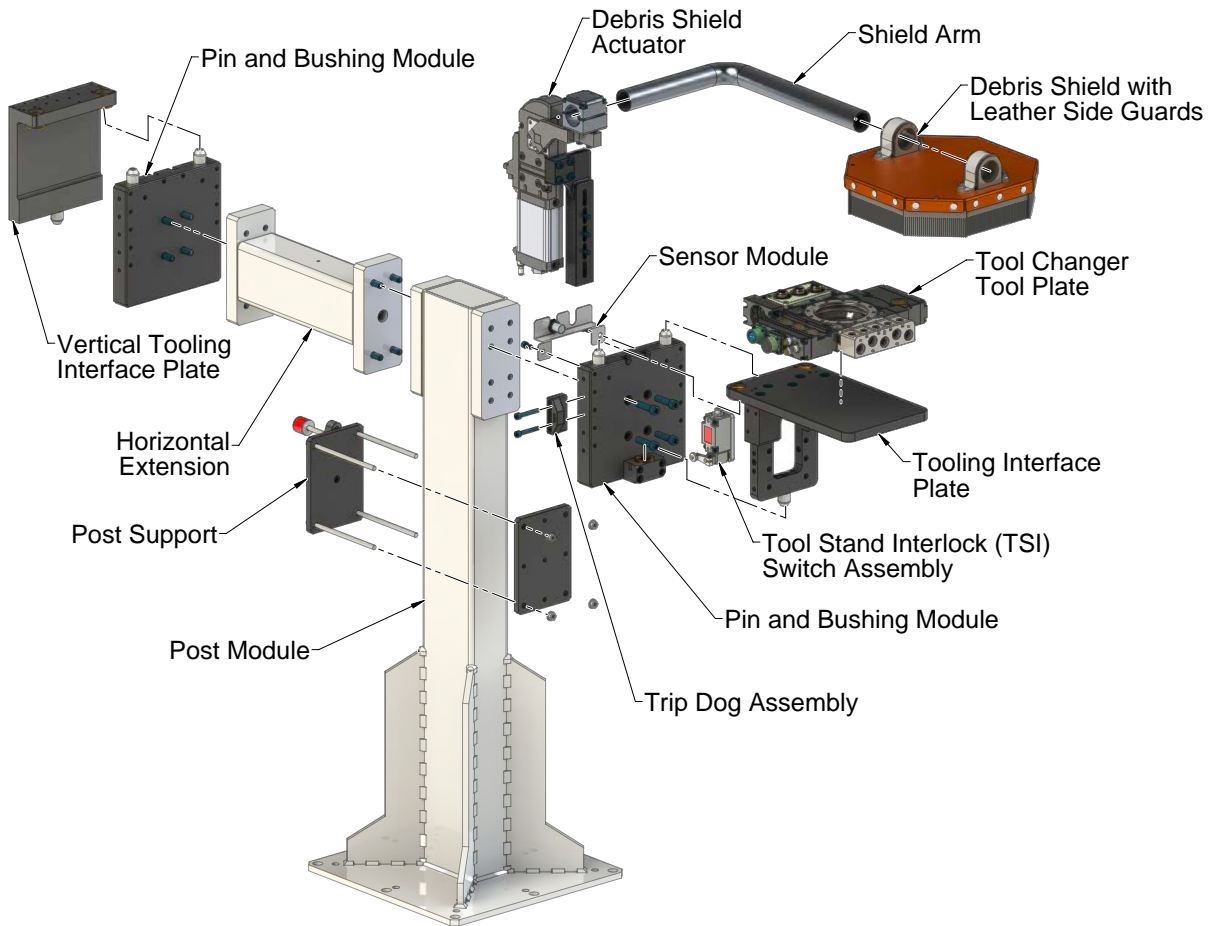
## 2. Product Overview

The ATI Tool Stand Large (TSL) system is compatible with ATI Tool Changer sizes QC-160 and larger. A customer can specify tool height, offset, shielding, and sensing. TSL configurations can be customized with actuated debris shields, mounting modules, tool stand interlock switches, horizontal extensions, and different types of tool sensing. An overview of TSL configurations and components are in the following sections.

### 2.1 TSL System with Pin and Bushing Style Mounting

One TSL system configuration is a pin and bushing mounting module. This mounting module adapts to an interface plate that attaches to the ATI Tool plate and customer tooling. To verify that the Tool plate is safely placed on the TSL, the user can install sensors and Tool Stand Interlock (TSI) systems. On the post module, a debris shield actuator and debris shield could be installed to protect the Tool plate and modules, when the Tool is not in operation. For customer tooling with a large center of gravity that is offset from the pin and bushing module, installation of additional post support may be required for needed structure stability and safety (contact ATI for assistance). Pin and bushing module configuration examples are in the following figure.

Figure 2.1—TSL System with Pin and Bushing Style Mounting





### 2.1.1 Post Module with Pin and Bushing Style Mounting

The TSL post module is a steel vertical post with welded gussets and a base plate. Two sides of the post are available for mounting pin and bushing modules. The standard post module is 48", contact ATI for other available heights.



Item	Part Number	Refer to the Drawing #:
Post Module, (1) Rigid Pin and Bushing Module, 48"	9120-TSL-PM-148B-R000	<a href="#">9630-20-TSL-PM-148B-R000</a>
Post Module, (2) Rigid Pin and Bushing Modules, 48"	9120-TSL-PM-248B-R000	<a href="#">9630-20-TSL-PM-248B-R000</a>
Notes:		
<ol style="list-style-type: none"> <li>1. Post modules are available in various heights, contact ATI for specification.</li> <li>2. Used with 9120-TSL-HBx and 9120-TSL-VBx type tooling interface plates.</li> <li>3. Used with sensor modules: 9120-TSL-SMA-XXXX.</li> </ol>		

### 2.1.2 Pin and Bushing Mounting Module

The pin and bushing mounting module includes (2) vertical alignment pins along the top of the module and (1) bushing at the bottom. These features are for aligning the interface plate to the mounting module as the Tool is placed in the Tool Stand. All pin and bushing modules mount directly to the post module with supplied fasteners. The module plate has mounting patterns for an optional debris shield actuator and sensor modules.



Item	Part Number	Refer to the Drawing #:
Pin and Bushing Module, Rigid	9120-TSL-RMB-R000	<a href="#">9630-20-TSL-RMB-R000</a>
Notes:		
<ol style="list-style-type: none"> <li>1. Used with 9120-TSL-HBx and 9120-TSL-VBx type tooling interface plates.</li> <li>2. Used with sensor modules: 9120-TSL-SMA-XXXX.</li> </ol>		

### 2.1.3 Tooling Interface Plates

An ATI Tool plate and the customer tooling can be installed vertically on a vertical interface plate or horizontally on a horizontal interface plate. Both interface plates are compatible with the pin and bushing modules (2) bushings align with the alignment pins on the module, and (1) alignment pin on the plate aligns with (1) bushing in the module.



Item	Part Number	Refer to the Drawing #:
Horizontal Tooling Interface Plate - Blank <sup>4</sup>	9120-TSL-HBB-4115	<a href="#">9630-20-TSL-HBB-4115</a>
Horizontal Tooling Interface Plate for QC-210	9120-TSL-HBC-9039	<a href="#">9120-TSL-HBC-9039</a>
Horizontal Tooling Interface Plate for QC-310	9120-TSL-HBC-9040	<a href="#">9120-TSL-HBC-9040</a>
Vertical Tooling Interface Plate		
Vertical Tooling Interface Plate - Blank <sup>4</sup>	9120-TSL-VBB-3328	<a href="#">9630-20-TSL-VBB-3328</a>
Vertical Tooling Interface Plate with (4) M8, (4) M6 Dowels <sup>4</sup>	9120-TSL-VBC-11618	<a href="#">9630-20-TSL-VBC-11618</a>
Notes:		
1. Used with post modules: 9120-TSL-PM-148B-XXXX and 9120-TSL-PM-248B-XXXX. 2. Used with mounting module 9120-TSL-RMB-R000. 3. Used with sensor modules: 9120-TSL-SMA-XXXX. 4. Used with a mechanical TSI switch and trip dog: refer to <a href="#">Section 2.1.6</a> and <a href="#">Section 2.3.2</a> .		

### 2.1.4 Sensor Modules

A sensor module detects Tool presence in the TSL. The sensor module mounts to the pin and bushing plate and includes a proximity sensor that detects a surface of the tooling interface plate. Other sensor options are available upon customer request; contact ATI for more information.



Item	Part Number	Refer to the Drawing #:
Dual Sensor Module, SS, Single PNP 18 mm Sensor, Shielded	9120-TSL-SMA-8090	<a href="#">9630-20-TSL-SMA-8090</a>
Dual Sensor Module, SS, No Sensors	9120-TSL-SMA-8089	<a href="#">9630-20-TSL-SMA-8089</a>

### 2.1.5 Proximity Sensors

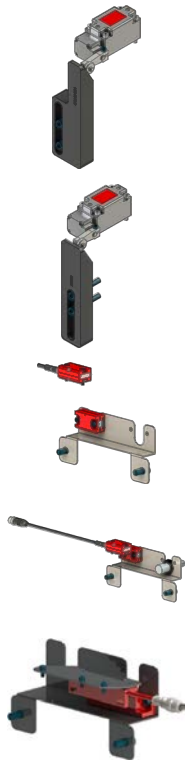
A proximity sensor detects Tool presence in the TSL. The sensor mounts to the sensor module and detects the surface of the tooling interface plate. Other sensor options are available upon customer request.



Item	Part Number	Refer to the Drawing #:
PNP Prox Sensor 5 mm sensing Range, 18 mm Barrel, Shielded	8590-9909999-92	<a href="#">9630-20-TSL-SMA-8090</a>

## 2.1.6 TSI Assemblies for Pin and Bushing Modules

Integration of a TSI assembly with a TSL and control/signal module prevents unplanned release of the Tool plate. The TSI switch mounts to the Tool interface plate and has a cable with a connector for the TSI connector on the Tool control/signal module. The trip dog or actuator mounts to the TSL. TSI assemblies that have mounting brackets specifically for the pin and bushing module configuration are listed in the following table: A customer can create other TSI assembly configurations with the components in [Section 2.3.2—Components to Configure a Custom TSI Assembly](#). For assistance or additional information, contact an ATI representative.

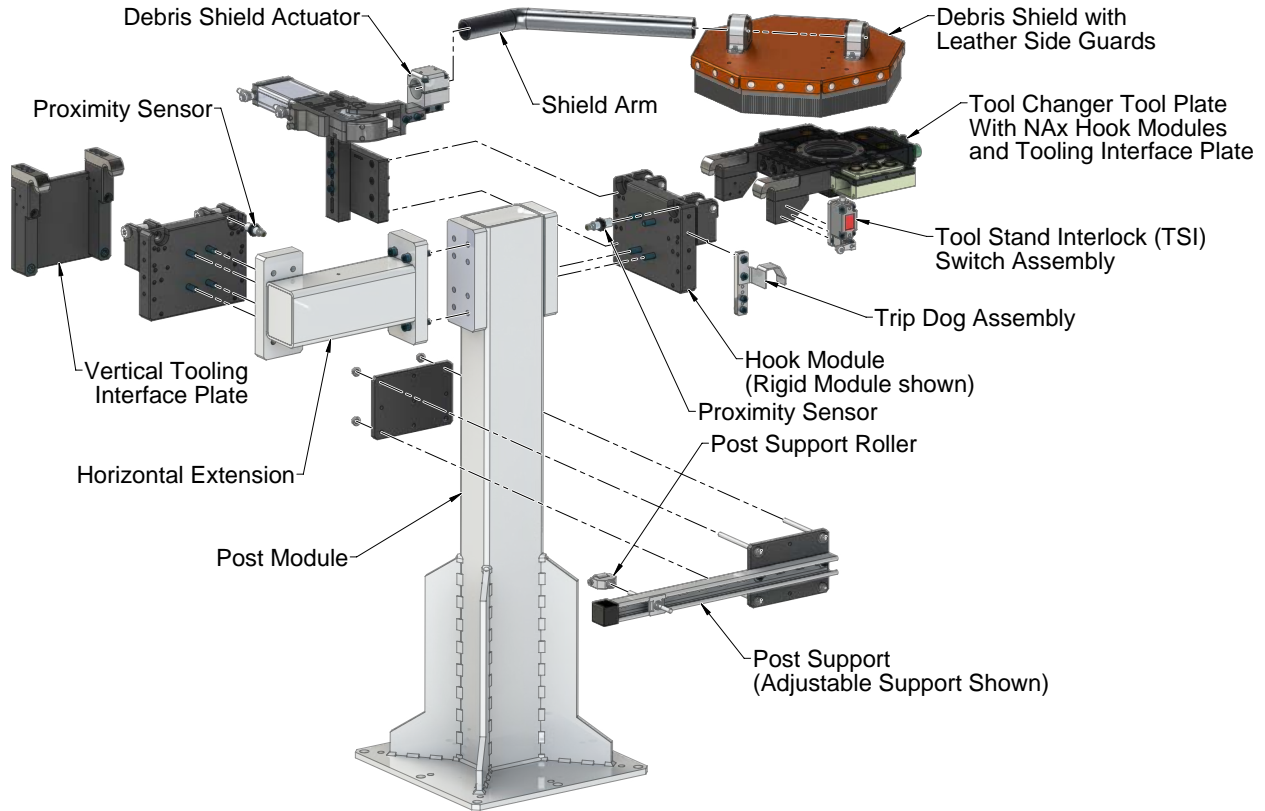


TSI Assemblies for the Pin and Bushing Mounting Configurations		
Item and description	Part Number	Refer to the Drawing #:
TSI Switch Assembly: trip dog (left side mounted) and Euchner mechanical switch	9120-TSL-SS-8078 and 9005-20-1165	Contact ATI for a drawing.
TSI Switch Assembly: trip dog (right side mounted) and Euchner mechanical switch	9120-TSL-SS-8079 and 9005-20-116	Contact ATI for a drawing.
TSI Switch Assembly: Non-Contact Euchner actuator and switch <sup>3</sup> with a .22m cable and M12 5-pin connector for TSI	9120-TSL-SS-9015	<a href="#">9630-20-TSL-SS-9015</a>
TSI Switch Assembly: Proximity sensor and a Non-Contact Euchner actuator and switch <sup>3</sup> with a .22m cable and M12 5-pin connector for TSI	9120-TSL-SS-9023	<a href="#">9630-20-TSL-SS-9023</a>
TSI Switch Assembly: Non-Contact Sipa actuator and switch <sup>3</sup> with a 1m cable and M12 5-pin connector for TSI	9120-TSL-SS-9018	<a href="#">9630-20-TSL-SS-9018</a>
Notes:		
<ol style="list-style-type: none"> <li>1. Contact an ATI representative for information about other TSI switch configurations available.</li> <li>2. The sensing range for the Sipa sensor is Make .35" (9 mm) and Break .47" (12 mm).</li> <li>3. Isolator pads included with both the switch and actuator.</li> <li>4. The TSI configuration depends on the control/signal module installed on the Tool Changer.</li> </ol>		

## 2.2 TSL System with Hook and Hanger Style Mounting

Another TSL system configuration is a hook and hanger mounting module assembly. This assembly includes a plate and NAX hook modules. This assembly configuration adapts to an interface plate that attaches to the ATI Tool plate and customer tooling. To verify that the Tool plate is safely placed on the TSL, the user can install sensors and Tool Stand Interlock (TSI) systems. On the post module, a debris shield actuator and debris shield could be installed to protect the Tool plate and modules, when the Tool is not in operation. For customer tooling with a large center of gravity that is offset from the hook and hanger module, installation of additional post support may be required for needed structure stability and safety (contact ATI for assistance). Hook and hanger style configuration examples are shown in the following figure.

**Figure 2.2—TSL System with Hook and Hanger Style Mounting**



## 2.2.1 Post Module with Hook and Hanger Style Mounting

The TSL post module is a steel vertical post with welded gussets and a base plate. Two sides of the post are for mounting the hook and hanger modules. The standard post module is 48", contact ATI for other available heights.



Item	Part Number	Refer to the Drawing #:
Post Module, (1) Rigid Hook Module, 48"	9120-TSL-PM-148H-R000	<a href="#">9630-20-TSL-PM-148H-R000</a>
Post Module, (2) Rigid Hook Modules, 48"	9120-TSL-PM-248H-R000	<a href="#">9630-20-TSL-PM-248H-R000</a>
Notes:		
<ol style="list-style-type: none"> <li>1. Post Modules are available in various heights, contact ATI for specification.</li> <li>2. Used with tooling interface plates: 9121-NA2-T, 9121-NA3-T, and 9121-TSL-TH-5641.</li> <li>3. Used with proximity sensors: 8590-9909999-XXX.</li> </ol>		

## 2.2.2 Hook Mounting Modules

The hook module mounts to the post module with the supplied fasteners (2) horizontal alignment pins on the module interface with the arms on hook type tool interface plates. The hook module has mounting patterns for an optional debris shield actuator, proximity sensor, and TSI actuator or trip dog.



Item	Part Number	Refer to the Drawing #:
Hook Module, Rigid	9120-TSL-RMH-R000	<a href="#">9630-20-TSL-RMH-R000</a>
Notes:		
<ol style="list-style-type: none"> <li>1. Used with tooling interface plates: 9121-NA2-T, 9121-NA3-T, and 9211-TSL-TH-5641.</li> <li>2. Used with proximity sensors: 8590-9909999-XXX.</li> </ol>		

## 2.2.3 Vertical Hook Tool Interface Plate Assembly

The vertical hook tool interface plate assembly has (2) hardened steel hooks that hang the assembly on the (2) horizontal alignment pins on the hook mounting module. The ATI Tool Changer and customer tooling mounts to the vertical interface plate. A mounting pattern along the plate permits the installation of a TSI switch.



Item	Part Number	Refer to the Drawing #:
Vertical Tooling Hook Plate Assembly, Blank	9121-TSL-TH-5641	<a href="#">9630-20-TSL-TH-5641</a>
Notes:		
<ol style="list-style-type: none"> <li>1. Used with post modules: 9120-TSL-PM-148H-XXXX and 9120-TSL-PM-248H-XXXX.</li> <li>2. Used with mounting module 9120-TSL-RMH-R000.</li> <li>3. Used with proximity sensors: 8590-9909999-XXX.</li> <li>4. Used with a mechanical TSI switch and trip dog: refer to <a href="#">Section 2.2.6</a>.</li> </ol>		

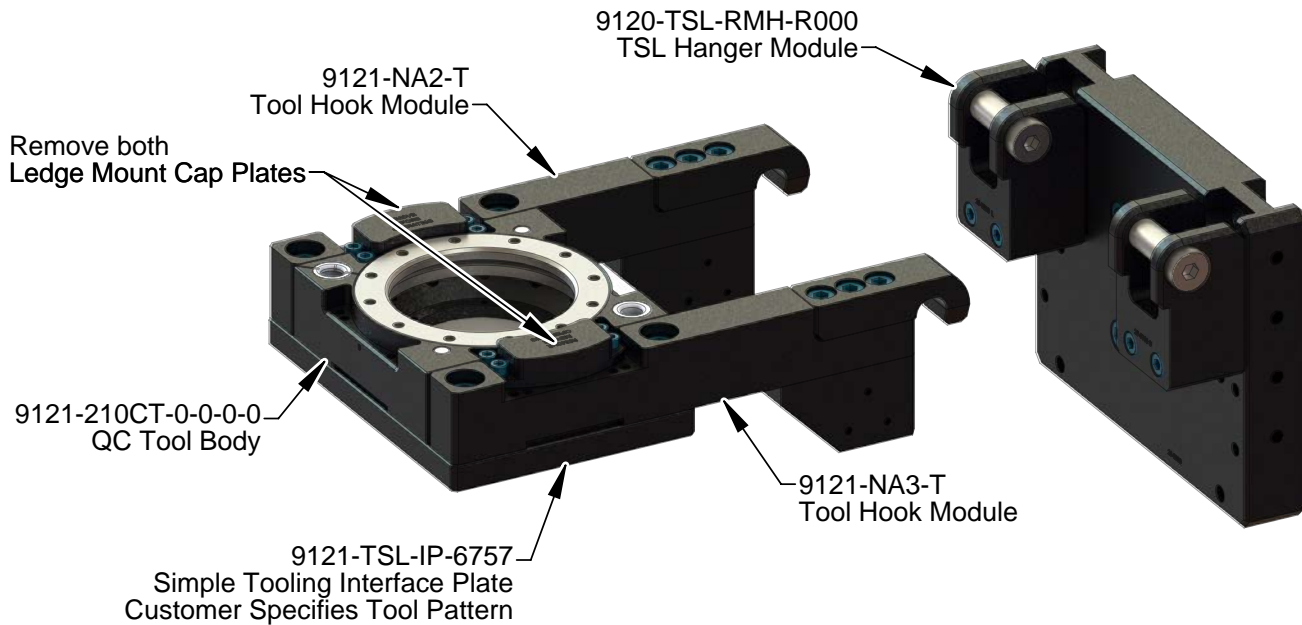
## 2.2.4 Horizontal Tool Hook Modules

Tooling hooks provide a compact method of robotic tool storage. The NAX series of tooling hook arms mount onto the sides of the QC-210 Tool changer base assembly. Base QC and NAX hooks must be secured to an interface plate or customer end-effector. A vertical tool hook plate option is also available.



Item	Part Number	Refer to the Drawing #:
Tool Hook Module, QC-210 Right	9121-NA2-T	<a href="http://www.ati-ia.com/products/toolchanger/QCModule.aspx?ID=NAX">http://www.ati-ia.com/products/toolchanger/QCModule.aspx?ID=NAX</a>
Tool Hook Module, QC-210 Left	9121-NA3-T	
Notes:		
1. Used with post modules: 9120-TSL-PM-148H-XXXX and 9120-TSL-PM-248H-XXXX.		
2. Used with mounting module: 9120-TSL-RMH-R000.		
3. Used with proximity sensors: 8590-9909999-XXX.		
4. Used with a mechanical TSI switch and trip dog: 9120-TSL-SS-5635 switch and trip dog left side, and 9120-TSL-SS-8024 trip dog only right side mounted.		

Figure 2.3—Tool Hook Modules (QC-210 with NA2 and NA3 shown)



## 2.2.5 Proximity Sensors

A proximity sensor detects Tool presence in the TSL. The sensor mounts to the hook and hanger module and detects the surface of either a vertical tool hook interface plate or a horizontal hook module. Other sensor options are available upon customer request.



Item	Part Number	Refer to the Drawing #:
PNP Prox Sensor 5 mm sensing Range, 18 mm Barrel, Shielded	8590-9909999-92	<a href="#">9630-20-TSL-SMA-8090</a>

## 2.2.6 TSI Systems for Hook and Hanger Modules

Integration of a TSI assembly with a TSL and control/signal module prevents unplanned release of the Tool plate. The TSI switch mounts to the hook arms or vertical tooling hook plate and has a cable with a connector for the TSI connector on the Tool control/signal module. The trip dog or actuator mounts to the TSL system. TSI assemblies that have mounting brackets specifically for the hook and hanger module configuration are listed in the following table: A customer can create other TSI assembly configurations with the components in [Section 2.3.2—Components to Configure a Custom TSI Assembly](#). For assistance or additional information, contact an ATI representative.



<b>TSI Mechanical Assembly for Horizontal Configuration (with hook module arms)</b>		
<b>Item and description</b>	<b>Part Number</b>	<b>Refer to the Drawing #:</b>
TSI Switch Assembly: trip dog (left side mounted) for NA2/NA3 hooks and Euchner mechanical switch	9120-TSL-SS-5635	<a href="#">9630-20-TSL-SS-5635</a>
TSI trip dog (right side mounted) only for NA2/3 hooks	9120-TSL-SS-8024	<a href="#">9630-20-TSL-SS-8024</a>
<b>TSI Mechanical Assembly for Vertical Configuration (with a vertical tooling hook plate)</b>		
TSI Euchner safety switch and connector assembly (trip dog is not included)	9120-TSL-SS-8074	<a href="#">9630-20-TSL-SS-8074</a>
<b>Sipa Sensor TSI Assembly for Vertical or Horizontal Configuration</b>		
TSL TSI - Hooks - Non-Contact Sipa actuator and switch with a 1m cable and M12 5-pin connector for TSI	9120-TSL-SS-9021	<a href="#">9630-20-TSL-SS-9021</a>
<b>Non-Contact Euchner TSI Assembly for Vertical or Horizontal Configuration</b>		
TSL TSI - Non-Contact Euchner actuator and switch with a 0.22m cable and a M12 5-pin connector for TSI	9120-TSL-SS-9024	<a href="#">9630-20-TSL-SS-9024</a>
Notes:		
<ol style="list-style-type: none"> <li>Other TSI switch configurations are available, contact ATI for information.</li> <li>The sensing range for the Sipa sensor is Make .35" (9 mm) and Break .47" (12 mm).</li> <li>TSI selection depends on the control/signal modules used on the Tool Changer.</li> </ol>		

## 2.3 Optional TSL System Components

Components that can be used with both the pin and bushing configuration or the hook and hanger configuration are covered in the following sections.

### 2.3.1 Horizontal Extension Modules

For more Tool clearance, an optional TSL horizontal extension module can attach to the TSL post module. The pin and bushing module or hook and hanger module mounts to the horizontal extension module. ATI offers a standard extension length of the 16" straight and a 12" 90°. Other lengths and configurations are available upon customer request.



Item	Part Number	Refer to the Drawing #:
Horizontal Extension, 16", Straight	9120-TSL-HE16S-8004	<a href="#">9630-20-TSL-HE16S-8004</a>
Horizontal Extension, 12", 90°	9120-TSL-HE12A-7572	<a href="#">9630-20-TSL-HE12A-7572</a>
Note: 1. The horizontal extension modules are available in other lengths and configurations; contact ATI for specifications.		

### 2.3.2 Components to Configure a Custom TSI Assembly

Integration of a TSI assembly with a TSL and control/signal module prevents unplanned release of the Tool plate. Customers can purchase TSI assemblies from ATI that have mounting assemblies for either the pin and bushing configuration or the hook and hanger configuration; refer to [Section 2.1.6—TSI Assemblies for Pin and Bushing Modules](#) and [Section 2.2.6—TSI Systems for Hook and Hanger Modules](#). A customer can create other TSI assembly configurations with the components in the following table: For TSI switches that interface with the Master control/signal module, the customer supplies the bracket for mounting the switch to interface with the Master. For assistance or additional information, contact an ATI representative.



TSI Switch and trip dog		
Item and description	Part Number	Refer to the Drawing #:
TSI Euchner safety switch and mounting plage (trip dog is not included)	9120-TSL-SS-6044	<a href="#">9630-20-TSL-SS-6044</a>
TSI trip dog	9120-TSL-SS-7511	<a href="#">9630-20-TSL-SS-7511</a>
TSI Switch for a Master Control/Signal Module		
TSI Euchner safety switch	9120-TSL-SS-6077	<a href="#">9630-20-TSL-SS-6077</a>
Sipha Sensor TSI Switch and Actuator		
Sipha sensor switch and actuator that supports TSI In/Out and TSIV, 1 m cable length <sup>2,3</sup>	9120-TSL-SS-7510	<a href="#">9630-20-TSL-SS-7510</a>
Sipha Sensor TSI Actuator		
TSI Sipha non-contact actuator <sup>2,3</sup>	9120-TSL-SS-7509	<a href="#">9630-20-TSL-SS-7509</a>





Euchner Non-Contact TSI Switch and Actuator		
TSI non-Contact Euchner actuator and switch with a 0.22 m Cable, M12 5-pin TSI connector	9120-TSL-SS-9019	<a href="#">9630-20-TSL-SS-9019</a>
TSI non-Contact Euchner actuator and switch with a 1.0m Cable, M12 5-pin TSI connector (mounting brackets are not included)	9120-TSL-SS-9022	<a href="#">9630-20-TSL-SS-9022</a>
Notes:		
<ol style="list-style-type: none"> <li>Contact an ATI representative for information about other TSI switch configurations available.</li> <li>Sipha sensor 9120-TSL-SS-7510 is used with sensor actuator 9120-TSL-SS-7509.</li> <li>The sensing range for the Sipha sensor is Make .35" (9 mm) and Break .47" (12 mm).</li> </ol>		

### 2.3.3 DSA (Debris Shield Actuator)

The DSA positions the debris shield in the open or closed position. The shield actuator mounts to the pin and bushing module or the hook module and has a pneumatic powerclamp that actuates the debris shield. The powerclamp uses PNP proximity sensing to detect the debris shield's open position. A shield arms clamps on the debris shield actuator, and the debris shield mounts to the shield arm. On a single TSL, the DSA can be oriented so that the shield swings in the vertical or horizontal plane. The shield hinge can be adjusted within a 135° range. For other configurations available, contact ATI.



Debris Shield Actuator - Horizontal		
Item	Part Number	Refer to the Drawing #:
Debris Shield Actuator - Horizontal - 135°	9120-TSL-DSA-135-7487	<a href="#">9630-20-TSL-DSA-135-7487</a>
Debris Shield Actuator - Vertical		
Debris Shield Actuator - Vertical - 135°	9120-TSL-DSA-135-7486	<a href="#">9630-20-TSL-DSA-135-7486</a>

### 2.3.4 Debris Shield and Shield Arm

The debris shield protects the Tool plate and Tool Changer modules from dust, weld spatter, and other debris when the Tool plate is not in operation. The debris shield attaches to an aluminum tubular shield arm that mounts to the debris shield actuator. The weld curtains on the debris shield are removable and can be ordered as spare parts for scheduled maintenance (refer to [Section 5.1.4.3—Inspection and Replacement Procedure for Debris Shield Weld Curtains](#)).



Debris Shields		
Item	Part Number	Refer to the Drawing #:
Debris Shield 20" with Weld Curtain Shields	9120-TSL-DS-20-W7787	<a href="#">9630-20-TSL-DS-20-W7787</a>
Debris Shield 17" with Weld Curtain Shields	9120-TSL-DS-17-W3528	<a href="#">9630-20-TSL-DS-17-W3528</a>
Debris Shield 14" with Weld Curtain Shields	9120-TSL-DS-14-W3337	<a href="#">9630-20-TSL-DS-14-W3337</a>
Shield Arms <sup>1</sup>		
Debris Shield Arm	3700-20-3376	N/A
Notes:		
1. Additional debris shield arm configurations are available; contact ATI for more information.		

### 2.3.5 Post-Mounted Tool Support

A post-mounted support provides structural stability and safety for the customer tooling while in the Tool Stand. These supports are mounted on the 4" or 6" post module. Supports include a fixed bumper; a support roller is available in place of the fixed bumper.



Item	Part Number	Refer to the Drawing #:
Adjustable Post Support with Arm	9120-TSL-PS-7980	<a href="#">9630-20-TSL-PS-7980</a>
Adjustable Post Support for Strut Channel	9120-TSL-PS-7979	<a href="#">9630-20-TSL-PS-7979</a>
Support - Roller	9120-TSL-PS-8229	<a href="#">9630-20-TSL-PS-8229</a>

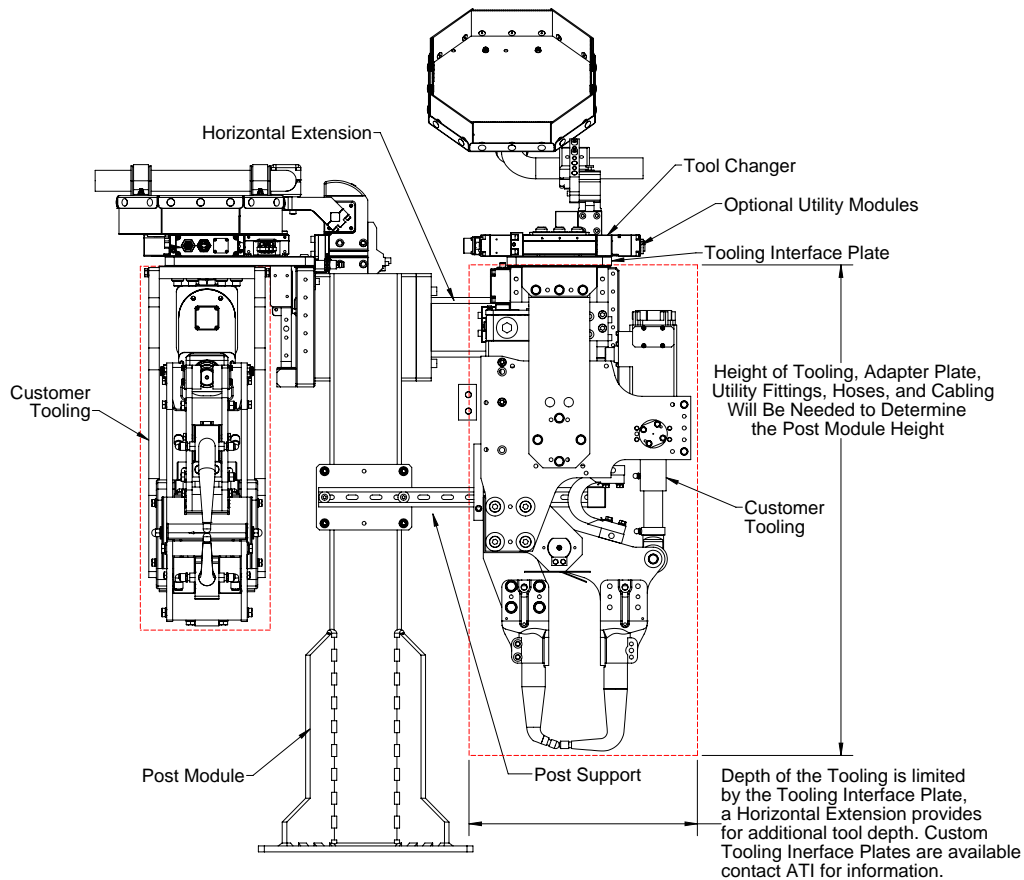
## 2.4 How to Determine a Tool Stand Configuration

Different post module heights and horizontal extensions are available to accommodate a variety of customer tooling sizes. Optional features can be assembled to the post module and extensions. The following optional features are available for Tool Changer models QC-160 and larger: tool presence detection, vertical and horizontal actuated debris shields, TSI switch assemblies, and post-mounted tool support options. Use horizontal or vertical tooling interface plates to secure the Tool Changer and customer tooling to the stand.

When selecting the Tool Stand components, consider the following points:

- The model Tool Changer being used and if add-on modules are required for the customer tooling
- The number of tools being supported, the required height, and the weight of tools
- The size, shape, and center of gravity of the end-effector and tooling. For hook and hanger configurations, refer to [Figure 2.7](#).
- The mounting module style: pin and bushing or hook and hanger
- The mounting orientation: vertical or horizontal tool interface plate
- The size, span, and capabilities of the robot being used
- The area available to accommodate the Tool Stand
- Consider including the following optional features: horizontal extension, tool presence sensing, TSI switch assembly, post-mounted tool support, and debris shields.

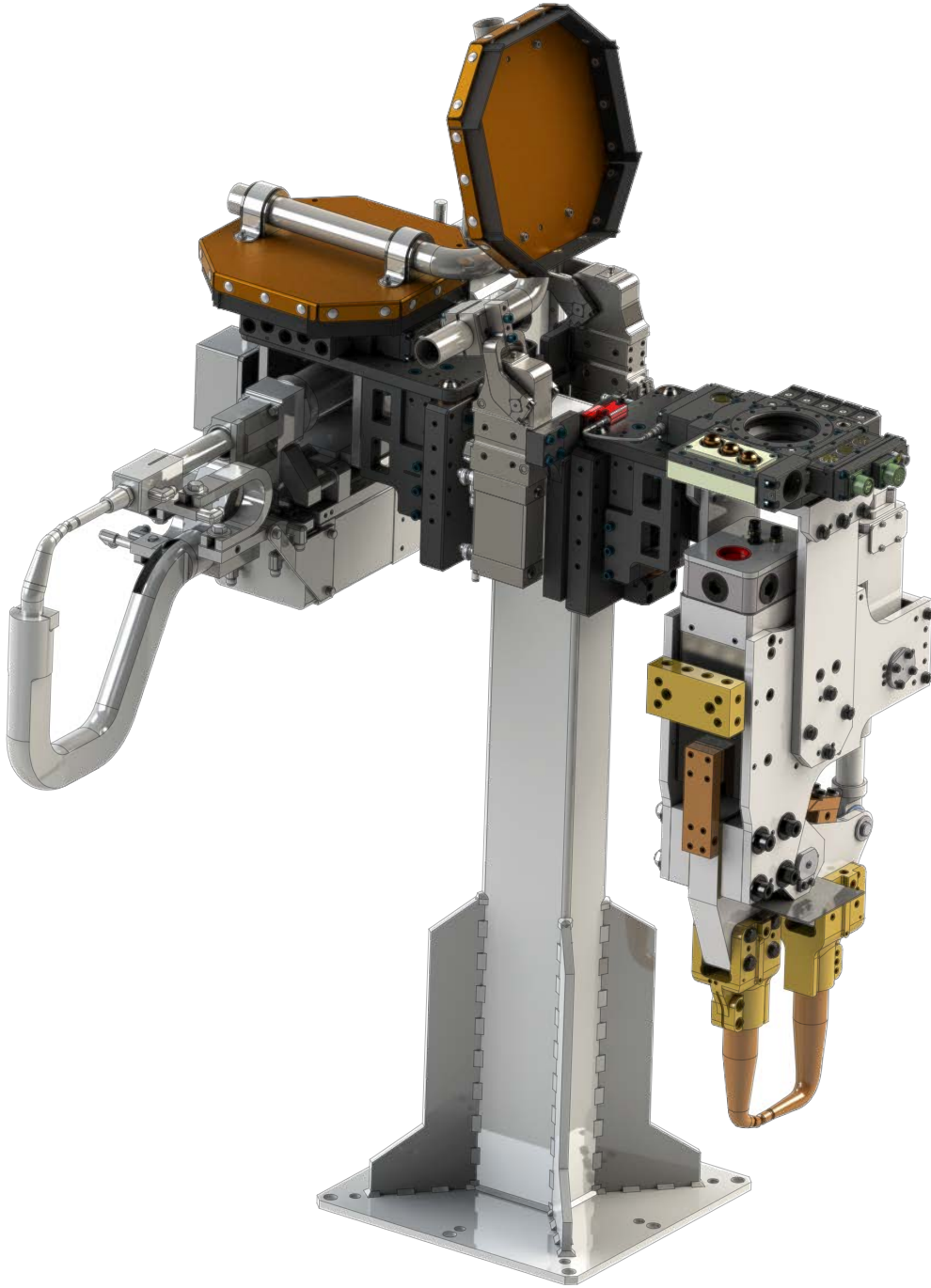
**Figure 2.4—Configuring a Tool Stand**



### 2.4.1 Configuration of a TSL System with Pin and Bushing Module

For a TSL system with a pin and bushing module configuration, the tool interface plate, to which the ATI Tool plate is installed, mounts directly to the pin and bushing module (refer to [Section 2.1—TSL System with Pin and Bushing Style Mounting](#) and [Section 2.3—Optional TSL System Components](#) for available components).

**Figure 2.5—TSL System with Pin and Bushing Configuration**



## 2.4.2 Configuration of a TSL System with a Hook and Hanger Module

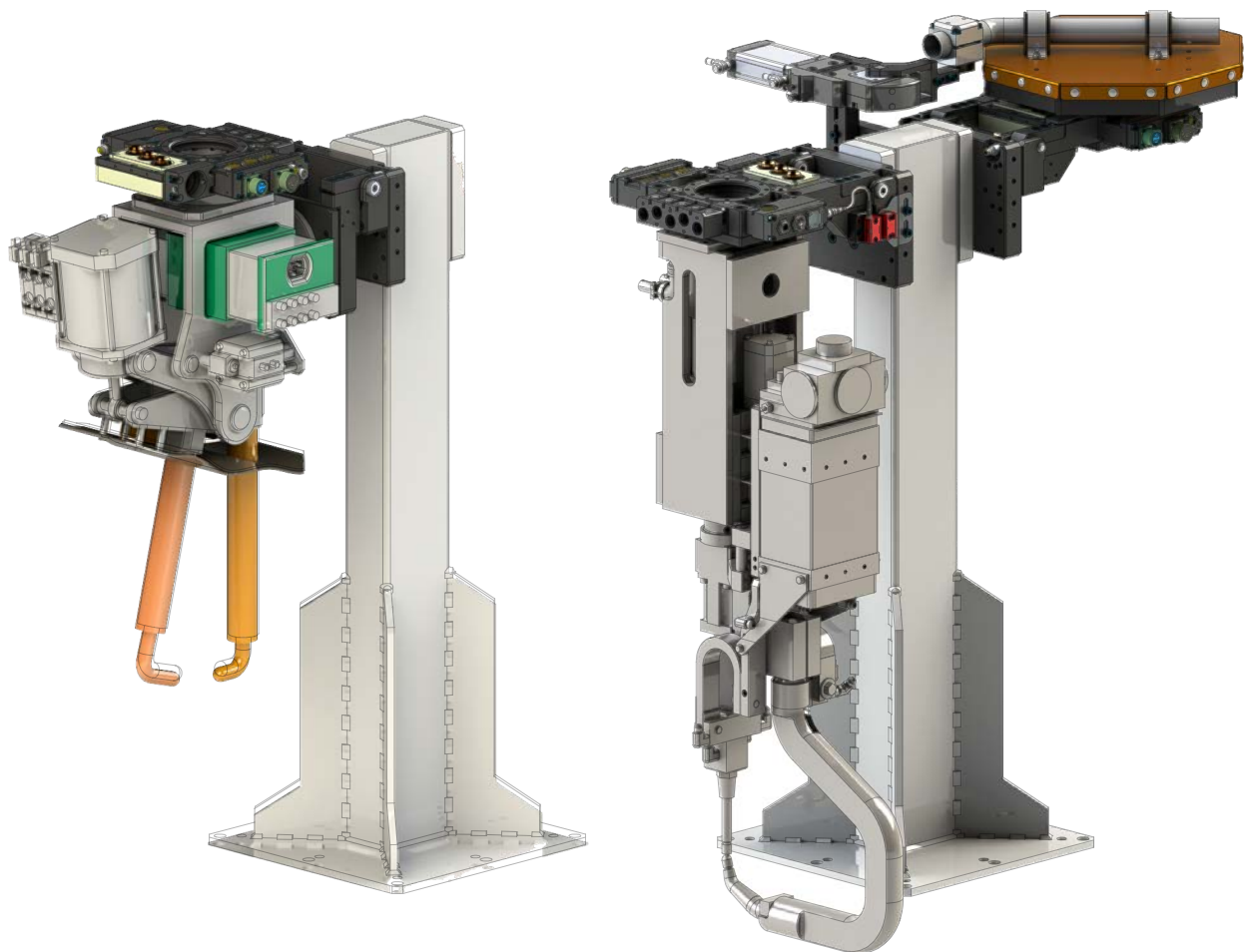


**WARNING:** Failure to properly configure a Tool Stand with a hook and hanger mounting module will result in injury to personnel and damage to the equipment. Contact ATI for assistance in configuring a proper Tool Stand for an application with the following items:

- The Tool Changer has weld, high current, or fluid/air modules.
- The center of gravity of the Tool Changer, modules, and customer tooling is outside the safe zone shown in [Figure 2.7](#).

For a TSL system with a hook and hanger module, these following two configurations are standard. In one vertical configuration, the hook arms are on a vertical tool interface plate, to which the customer tooling is installed, mounts to the hook and hanger module (refer to left configuration in the following figure). In the second horizontal configuration, the hook module arms attach directly on the ATI Tool plate which mounts to the hook and hanger module (refer to the right configuration in the following figure). For available components, refer to [Section 2.1—TSL System with Pin and Bushing Style Mounting](#) and [Section 2.3—Optional TSL System Components](#). To ensure that the payload and center of gravity are within a safe zone and should not require additional supports, refer to [Figure 2.7](#).

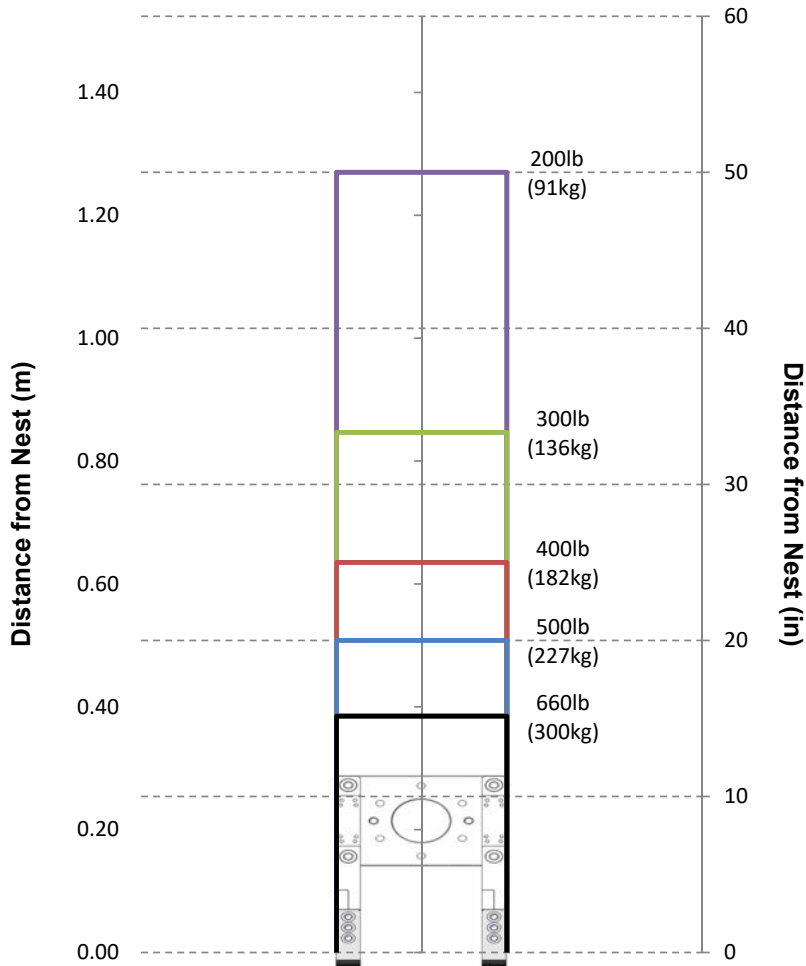
**Figure 2.6—TSL System with Hook and Hanger Configuration**



For a Tool Stand with a hook and hanger configuration, safe zones for different payloads and the distance of their center of gravity from the hook and hanger module are shown in the following figure. If the center of gravity for the Tool plate, modules, and customer tooling is outside of the zone for the respective payload, then the user should contact ATI for assistance in configuring a Tool Stand.

If the Tool is configured with modules for welding or fluid operations, the user should contact ATI for assistance in configuring the Tool Stand.

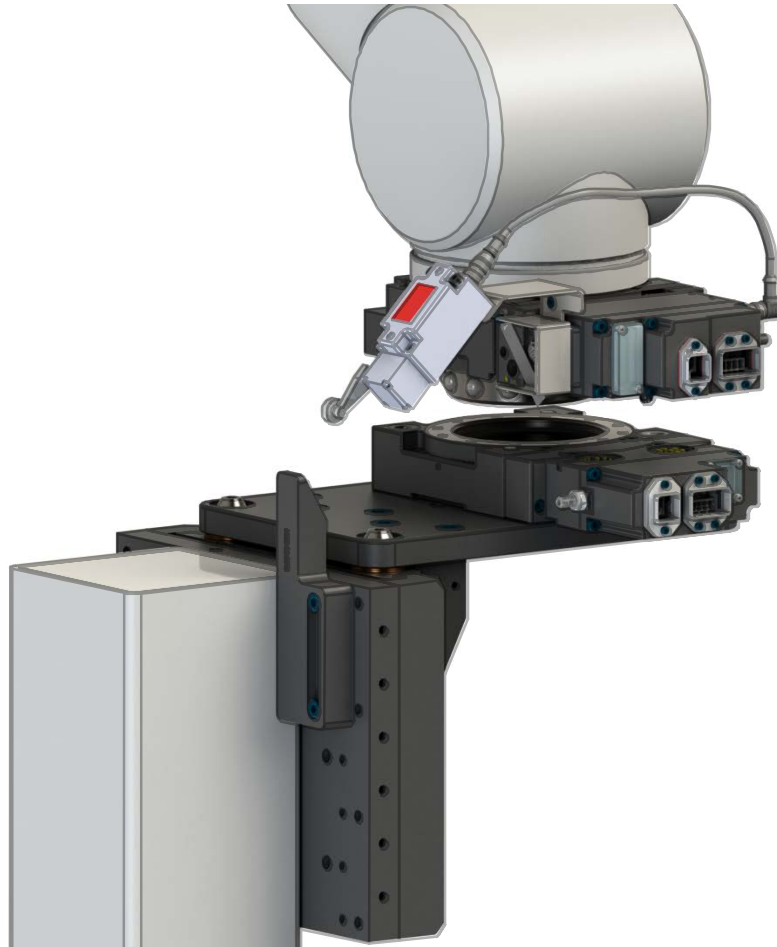
**Figure 2.7—Safe Zone Map for a Tool Stand Hook and Hanger Module Configuration**



### 2.4.3 Configuration of a TSL System with TSI Switch on the Master

For a TSL configuration with a TSI switch on the Master side of the Tool Changer, the customer must supply a bracket to mount the TSI switch. The TSI switch is installed on the Master side, if the signal/control module has a TSI connector on the Master module and not the Tool module. An example configuration is in the following figure. For available TSI components, refer to [Section 2.3—Optional TSL System Components](#).

**Figure 2.8—TSL System with TSI Switch on the Master Side**



### 3. Installation

ATI does not assemble the TSL configuration at its factory; therefore, the customer must assemble the TSL configuration to best suit the customer application.



**WARNING:** All pneumatic fittings and tubing must be capable of withstanding the repetitive motions of the application without failing. The routing of electrical and pneumatic lines must minimize the possibility of over stressing, pullout, or kinking the lines. Failure to do so can cause critical electrical and/or pneumatic lines to malfunction and might result in injury to personnel or damage to equipment.



**CAUTION:** Improper cable routing can result in wires and cables being pinched in the joint between the Tool Changer plates and premature failure of the electrical connectors. Properly route and secure all cables, particularly on the Master side.



**CAUTION:** Thread locker applied to fasteners must not be used more than once. Fasteners might become loose and cause equipment damage. Always apply new thread locker when reusing fasteners.

#### 3.1 Installing the Post Module, Pin and Bushing or Hook and Hanger Module

*Tools required:* 10 mm and 17 mm hex key, torque wrench

*Supplies required:* Loctite 242®

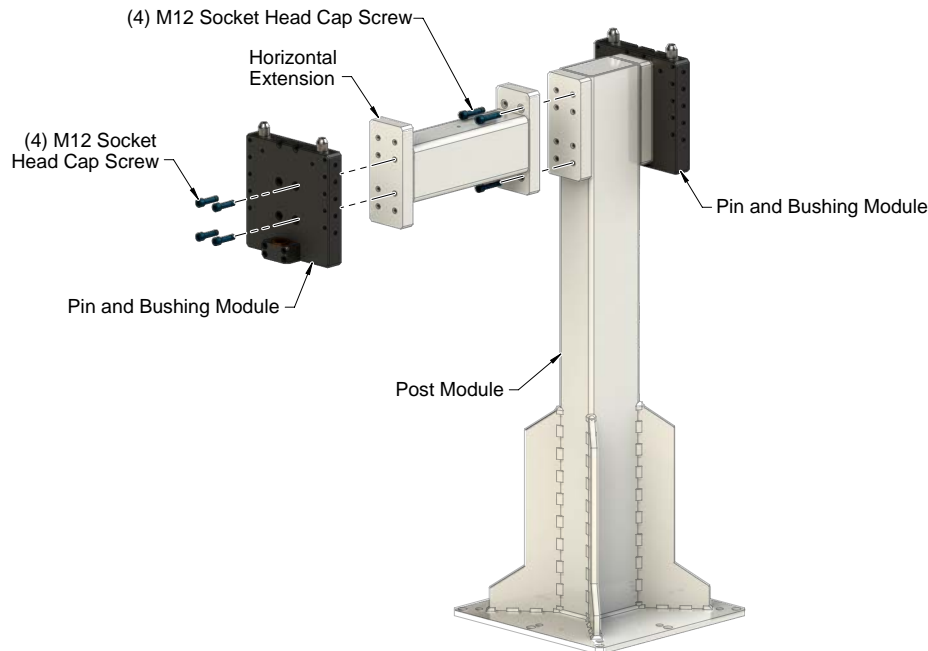
1. Determine the location and orientation for the TSL configuration.
2. Level and mount the post module (mounting fasteners are customer supplied).
  - a. Use the (8) 20 mm through holes that are on the base plate to anchor the post module to a smooth flat level floor.
  - b. Use the (8) M12 threaded holes in the base plate for leveling.

**NOTICE:** The M12 socket head cap screws, which are supplied by ATI, have pre-applied threadlocker. Do not use the threadlocker more than once. Apply Loctite 242 to the threads before re-installation.

3. Install the horizontal extension, if applicable.
  - a. Apply Loctite 242 to the (4) M12 socket head caps screws that are supplied with the horizontal extension.
  - b. Attach the horizontal extension to the post module with the (4) M12 socket head cap screws and tighten to 65 ft-lbs (88.13 Nm) using a 10 mm hex key.
4. Install the pin and bushing module(s) and hook module(s), if applicable.
  - a. Attach the pin and bushing or hook module to the post module or horizontal extension with the (4) M12 socket head cap screws, using a 10 mm hex key. Tighten to 65 ft-lbs (88.13 Nm).



**Figure 3.1—Installing a Horizontal Extension and Pin and Bushing or Hook Module**



**NOTICE:** If a tooling interface plate or vertical tooling hook plate is blank, the mounting pattern for the customer tooling must be machined into the plate. For detailed information, see the drawings referenced in [Section 2.1.3—Tooling Interface Plates](#).

5. Assemble the Tool Changer Tool plate, customer tooling, and tooling interface plate, or vertical tooling hook plate, if applicable. Refer manual for the specific Tool Changer model being installed ([http://www.ati-ia.com/products/toolchanger/tool\\_changer\\_models.aspx](http://www.ati-ia.com/products/toolchanger/tool_changer_models.aspx)).



**WARNING:** If NAX tool hook modules are being used to mount the Tool Changer and customer tooling, the Tool Changer and the tool hook modules must be attached to the interface plate. Failure to attach the Tool Changer and the tool hook modules to the interface plate could cause damage to equipment or injury to personnel.

6. Install the tool hook modules as instructed in [Section 3.2—Hook Arm Installation](#), if applicable.
7. Position tool assembly (tooling interface plate, Tool Changer Tool plate, and customer tooling) on the pin and bushing module or the hook module on the TSL system. Note: Verify that the tool rests even and parallel in the Tool Stand.
8. To continue assembling the configuration, refer to the following sections as applicable:
  - For a proximity sensor, refer to [Section 3.3—Install a Sensor Module to a Pin and Bushing Module](#) and [Section 3.4—Install a Proximity Sensor to a Hook Module](#)
  - For a TSI switch assembly, refer to [Section 3.5—Installation of a Tool Stand Interlock \(TSI\) Switch Assembly](#)
  - For debris shield, refer to [Section 3.6—Installing a Debris Shield](#)
  - For a post module tool support and post support roller, refer to [Section 3.7—Installing a Post-mounted Tool Support and Post Support Roller](#)

### 3.2 Hook Arm Installation

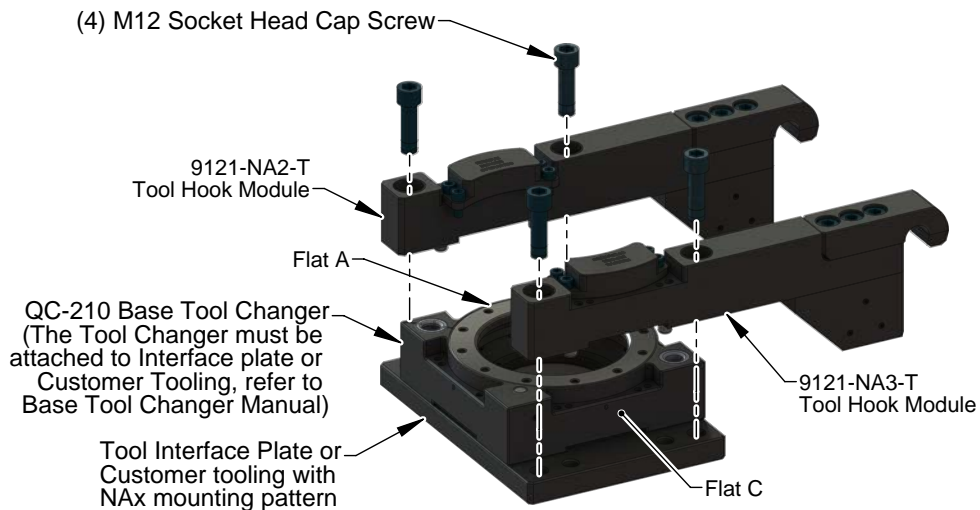
Refer to [Figure 3.2](#) and [Figure 3.3](#).

**Tools required:** 5 mm and 10 mm hex key, torque wrench

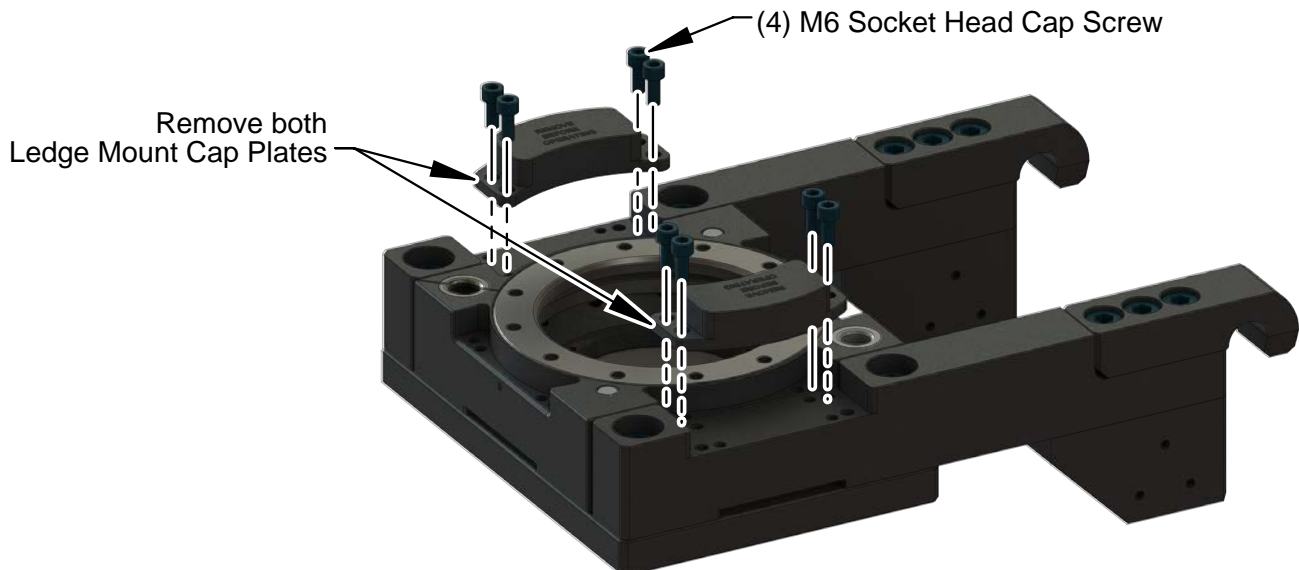
**Supplies required:** Loctite® 242

1. Attach the QC-210 base Tool Changer to the tool interface plate or customer tooling with the tool hook mounting pattern machined into it. Refer to [9620-20-B-210 Series Base Tool Changer](#) manual for more information and guidelines for bolt tightening.
2. Attach the left and right side tool hook modules onto the ATI-supplied interface plate or customer tooling with NAX mounting pattern. Be sure that there are (2) M10 dowel pins included in the mounting for each hook arm module.
3. Apply Loctite 242 or similar to the M12 socket head cap screws.
4. Insert the M12 socket head cap screws through the tool hook modules into the interface plate or customer tooling. Using a 10 mm hex key, tighten to 65 ft-lbs (88.12 Nm).
5. Remove both ledge mount cap plates from the Tool Changer and tool hook modules. Discard the ledge mount cap plates (for shipping purposes only).

**Figure 3.2—Mount Tool Hook Modules to the Interface Plate**



**Figure 3.3 —Remove the Ledge Mount Cap Plates**



### 3.3 Install a Sensor Module to a Pin and Bushing Module

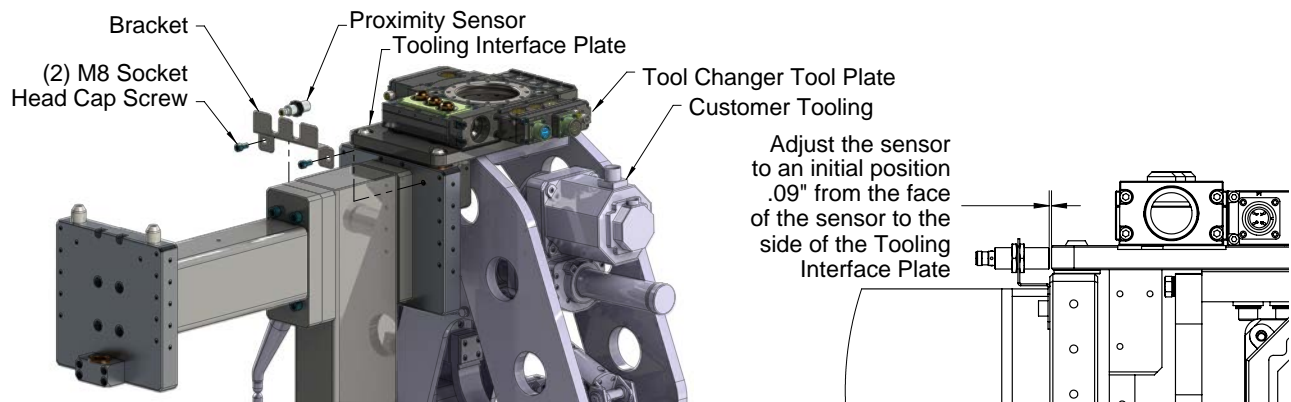
For other sensor modules available, contact ATI for assistance and installation instructions.

#### 3.3.1 Dual Sensor Module Installation

**Tools required:** 6 mm hex key, (2) 24 mm wrenches, torque wrench

1. Install the bracket as shown in *Figure 3.4*.
2. Using a 6 mm hex key, secure the bracket using the (2) M8 socket head cap screws. Tighten to 25 in-lbs (2.82 Nm).
3. Slide the proximity sensor on the bracket and position so the face of the sensor is .09" from the side of the tooling interface plate.
4. Tighten the jam nuts finger tight, and connect the sensor cable.
5. Cycle the Tool pick-up and drop-off, and adjust the sensor position. Tighten the jam nuts using 24 mm wrenches.

**Figure 3.4—Dual Sensor Module Installation**



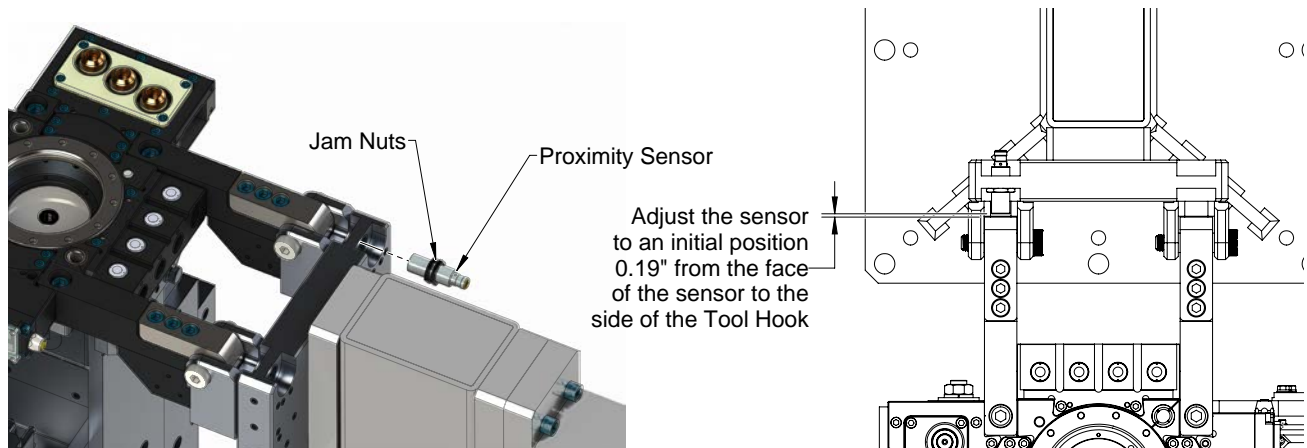
### 3.4 Install a Proximity Sensor to a Hook Module

**Tools required:** 2 mm, 6 mm, and 8 mm hex key, (2) 24 mm wrenches, torque wrench

**Supplies required:** Loctite 242

1. Thread the proximity sensor into the hook module and position so the face of the sensor is 0.19" from the side of the hook.
2. Tighten the jam nuts finger tight, and connect the sensor cable.
3. Cycle the Tool pick-up and drop off and adjust the sensor position to achieve the desired result. Tighten the jam nuts using 24 mm wrenches.

**Figure 3.5—Install a Proximity Sensor to a Hook Module**



### 3.5 Installation of a Tool Stand Interlock (TSI) Switch Assembly

There are several possible configurations for installing a TSI switch assembly to a pin and bushing module or hook and hanger modules. Installation procedures for standard configurations are provided in the following sections.

A summary of the Tool Stand configuration and TSI assembly procedures are provided as a reference in the following table:

<b>Table 3.1—TSI Switch Assembly and Tool Stand Configurations</b>			
<b>Configuration</b>			<b>Refer to the Procedure in Section:</b>
<b>Tool Stand Mounting Module</b>	<b>Interface plate or Hooks Type</b>	<b>TSI Switch Assembly</b>	
Pin and Bushing	Horizontal	TSI Switch <sup>1</sup> and trip dog	<a href="#">3.5.1</a>
	Vertical	TSI Switch <sup>1</sup> and trip dog	<a href="#">3.5.2</a>
	Horizontal or Vertical	Non-Contact Euchner TSI Switch and Actuator	<a href="#">3.5.3</a>
		Non-Contact Sipa TSI Switch and Actuator	<a href="#">3.5.4</a>
Hook and Hanger	NAx Hook Arm or Vertical Tool Hook Plate	TSI Switch <sup>1</sup> and trip dog	<a href="#">3.5.5</a>
		Non-Contact Euchner TSI Switch and Actuator	<a href="#">3.5.6</a>
		Non-Contact Sipa TSI Switch and Actuator	<a href="#">3.5.7</a>
Notes:			
1. For a TSI switch that interfaces with a Master control/signal module, the customer must supply and assemble the bracket to the switch.			

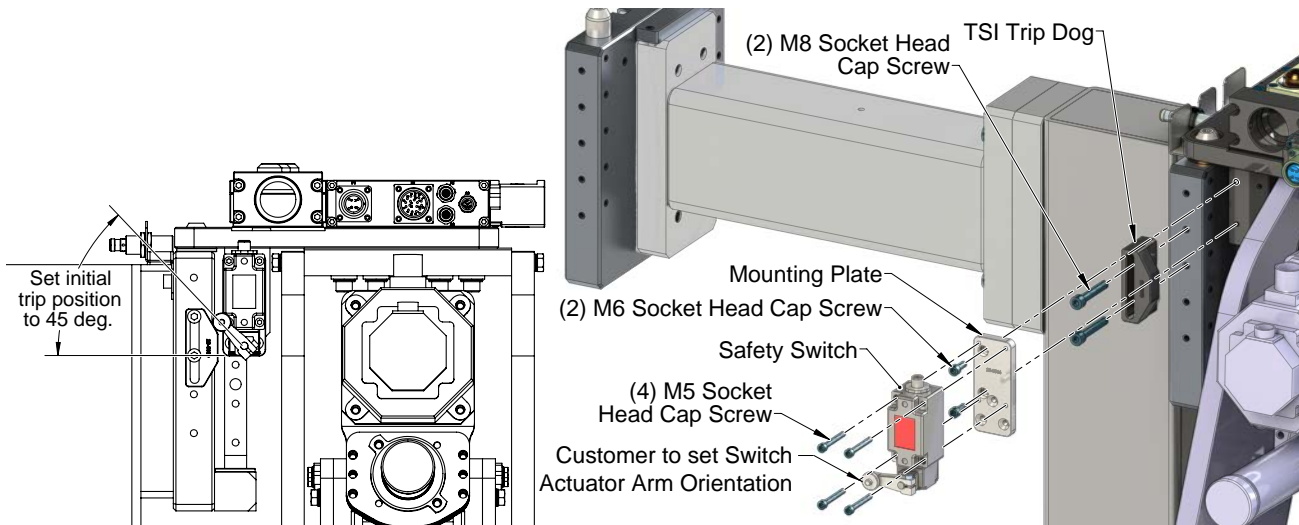
### 3.5.1 Install a TSI Switch Assembly on a Pin and Bushing Module and Horizontal Tool Interface Plate

*Tools required:* 4 mm, 5 mm, and 6 mm hex key, torque wrench

*Supplies required:* Loctite 242

1. Install the mounting plate to the tooling interface plate as shown in [Figure 3.6](#).
2. Secure with the (2) M6 socket head cap screws supplied. Tighten to 50 in-lbs (5.65 Nm) using a 5 mm hex key.
3. Install the safety switch to the mounting plate.
4. Apply Loctite 242 to the (4) M5 socket head cap screws supplied with the safety switch.
5. Install the safety switch to the mounting plate with the (4) M5 socket head cap screws. Tighten to 50 in-lbs (5.65 Nm) using a 4 mm hex key. Note: The safety switch actuator arm can be repositioned to the desired location. Refer to the manufacturer instruction for repositioning the actuator.
6. Apply Loctite 242 to the (2) M8 socket head cap screws supplied with the trip dog.
7. Install the trip dog to the pin and bushing module secure with the (2) M8 socket head cap screws using a 6 mm hex key.
8. Position trip dog so that it will actuate the safety switch about 45° with the tooling secure in the Tool Stand. Note: do not actuate the switch more than 75°. Tighten the screws to hold the position.
9. Connect the cable from the safety switch to the Tool side control/signal module.
10. Cycle the Tool pick-up and drop off and adjust the trip dog position. Tighten the (2) M8 socket head cap screws to 100 in-lbs (11.3 Nm) using a 6 mm hex key.

**Figure 3.6—Installing a TSI Switch to a Pin and Bushing Module with a Tooling Interface Plate**



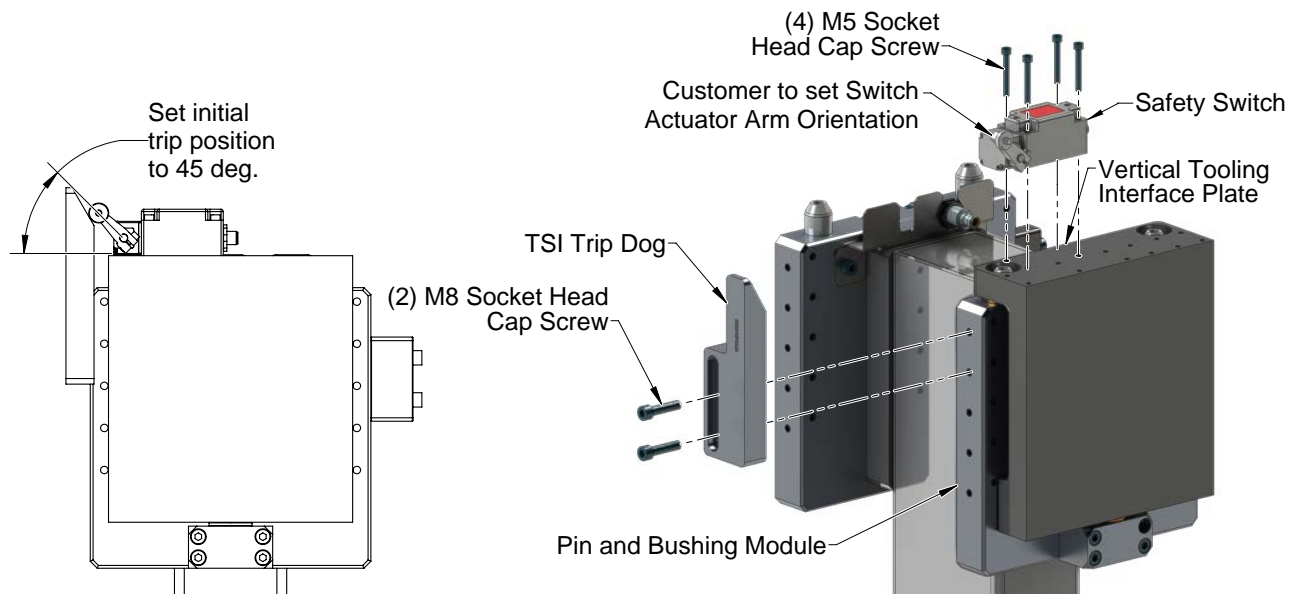
### 3.5.2 Installation of a TSI Switch Assembly to a Pin and Bushing Module and Vertical Tooling Interface Plate

*Tools required:* 4 mm and 6 mm hex key, torque wrench

*Supplies required:* Loctite 242

1. Apply Loctite 242 to the (4) M5 socket head cap screws supplied with the safety switch.
2. Install the safety switch to the vertical tooling interface plate, as shown in [Figure 3.7](#).
3. Secure the switch with the (4) M5 socket head cap screws. Tighten to 50 in-lbs (5.65 Nm) using a 4 mm hex key. Note: The safety switch actuator arm can be repositioned to the desired location. Refer to the manufacture instruction for repositioning the actuator.
4. Apply Loctite 242 to the (2) M8 socket head cap screws supplied with the trip dog.
5. Install the trip dog to the pin and bushing module and secure with the (2) M8 socket head cap screws using a 6 mm hex key.
6. Position the trip dog so that it will actuate the safety switch about 45° with the tooling secure in the Tool Stand. Note: do not actuate the switch more than 75°. Tighten the screws to hold the position.
7. Connect the cable from the safety switch to the Tool side control/signal module.
8. Cycle the Tool pick-up and drop off and adjust the trip dog position. Tighten the (2) M8 socket head cap screws to 100 in-lbs (11.3 Nm) using a 6 mm hex key.

**Figure 3.7—Installing a TSI Switch to a Pin and Bushing Module with a Vertical Tooling Interface Plate**



### 3.5.3 Pin and Bushing Module: Installation of a Non-Contact Euchner TSI Switch and Actuator

*Tools required:* 3 mm hex key, torque wrench

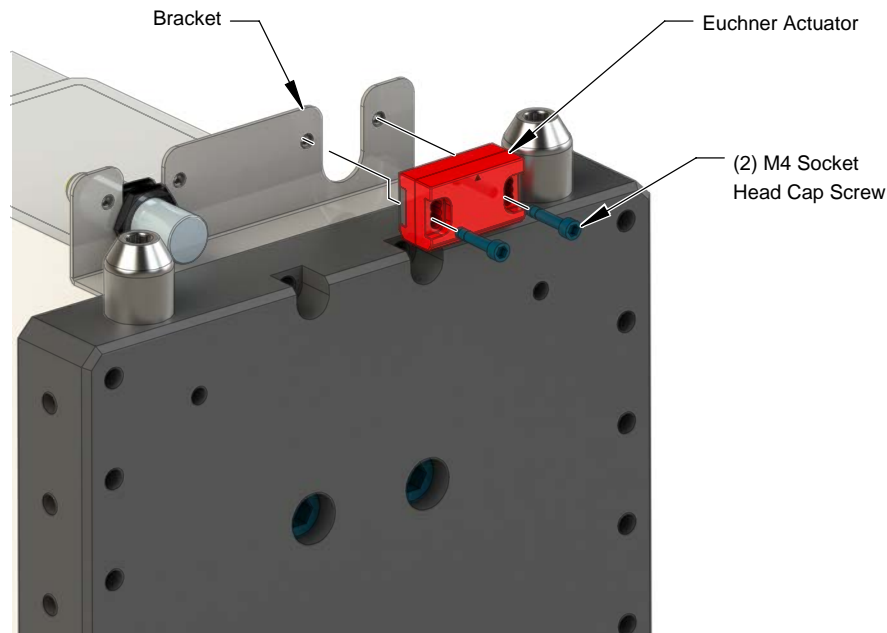
*Supplies required:* Loctite 222

1. Install the bracket to the interface plate; refer to [Section 3.3.1—Dual Sensor Module Installation](#) step 1 through step 2.

**NOTICE:** The (2) M4 socket head cap screws have pre-applied threadlocker. Do not use the threadlocker more than once. Apply Loctite222 to the threads before re-installation.

2. Install the Euchner actuator on the bracket.
  - a. Using a 3 mm hex key, secure the actuator to the bracket with the (2) M4 socket head cap screws. Note: The actuator's mounting pattern allows for vertical adjustments along the bracket.
  - b. Tighten the screws to 7.08 in-lbs (0.8 Nm). Do not over tighten.

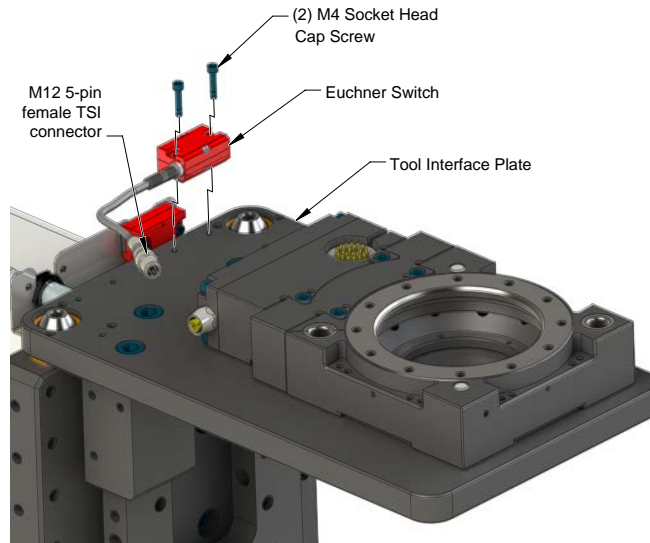
**Figure 3.8—Euchner Actuator Installation**



3. Install the Euchner switch to the tool interface plate (refer to [Figure 3.9](#)).
  - a. Using a 3 mm hex key, secure the switch to the tool interface plate with the (2) M4 socket head cap screws.
  - b. Tighten the screws to 7.08 in-lbs (0.8 Nm). Do not over tighten.
4. Connect the M12 connector on the Euchner switch cable to the TSI connector on the Tool control/signal module.
5. Cycle the Tool pick-up and drop-off and adjust to the desired position.



**Figure 3.9—Euchner Switch Installation**



### 3.5.4 Pin and Bushing Module: Installation of a Sipa TSI Switch and Actuator

*Tools required:* 3 mm hex key, torque wrench

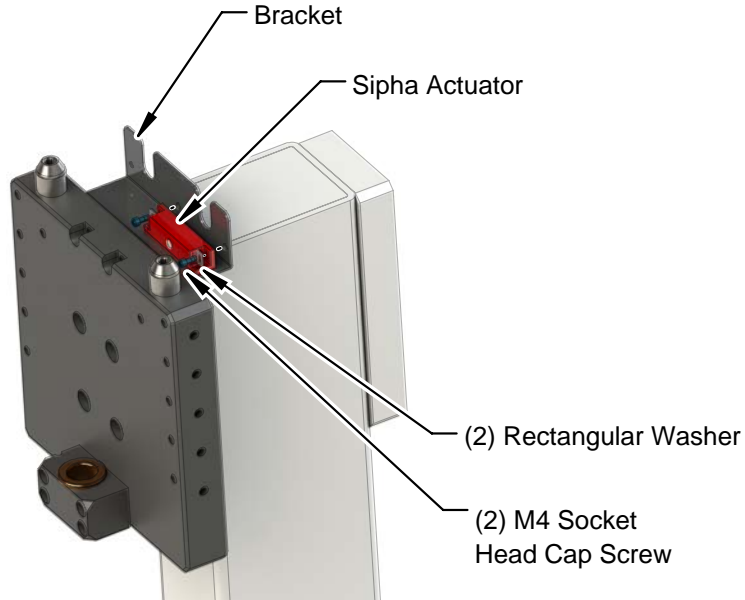
*Supplies required:* Loctite 222

1. Install the bracket to the interface plate; refer to [Section 3.3.1—Dual Sensor Module Installation](#) step 1 through step 2.

**NOTICE:** The M4 socket head cap screws have pre-applied threadlocker. Do not use the threadlocker more than once. Apply Loctite 222 to the threads before re-installation.

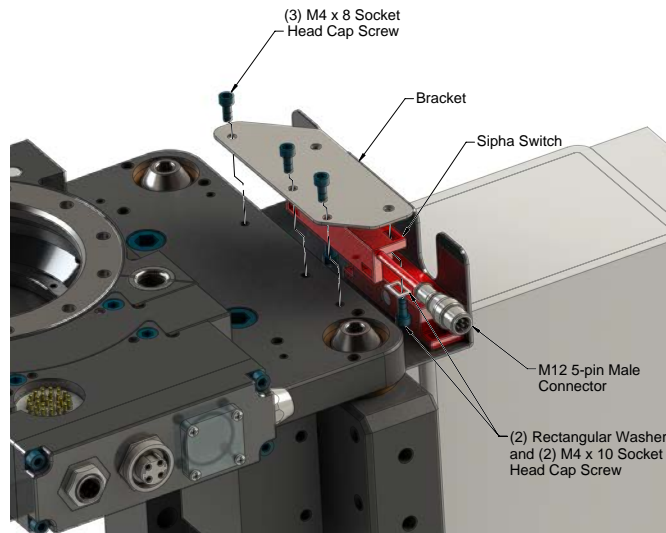
2. Install the Sipa actuator on the bracket (refer to [Figure 3.10](#)):
  - a. Using a 3 mm hex key, secure the actuator to the bracket with the (2) rectangular washers and (2) M4 socket head cap screws. Note: The actuator's mounting pattern allows for vertical adjustments along the bracket.
  - b. Tighten the screws to 8.85 in-lbs (1 Nm). Do not over tighten.

**Figure 3.10—Sipha Actuator Installation**



3. Install the Sipha switch to the interface bracket:
  - a. Using a 3 mm hex key, secure the switch to the interface bracket with the (2) rectangular washers and (2) M4 socket head cap screws.
  - b. Tighten the screws to 8.85 in-lbs (1 Nm). Do not over tighten.
4. Install the interface bracket to the tool interface plate:
  - a. Using a 3 mm hex key, secure the switch to the interface bracket with the (3) M4 socket head cap screws.
  - b. Tighten the screws to 8.85 in-lbs (1 Nm). Do not over tighten.
5. Connect the M12 connector on the Sipha switch cable to the TSI connector on the Tool control/signal module.
6. Cycle the Tool pick-up and drop off and adjust to the desired position.

**Figure 3.11—Sipha Switch Installation**



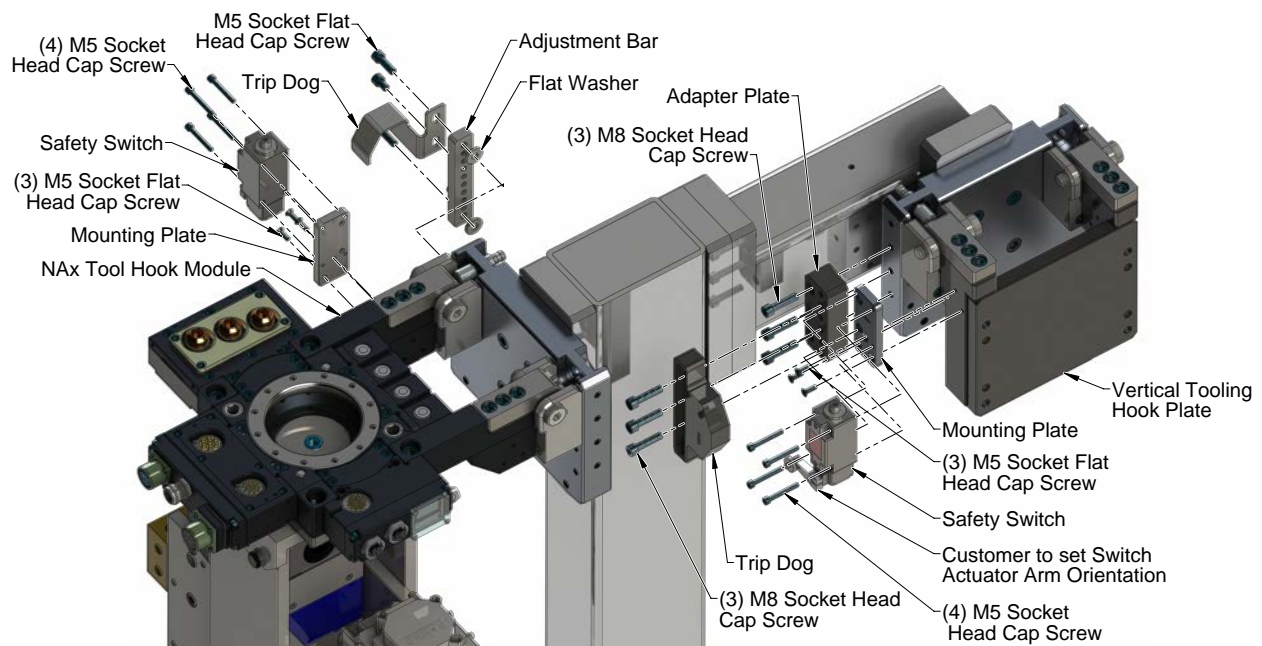
### 3.5.5 Hook Module with Vertical Tooling Hook Plate or Tool Hook Modules (Limit Switch)

*Tools required:* 4 mm and 6 mm hex key, torque wrench

*Supplies required:* Loctite 242

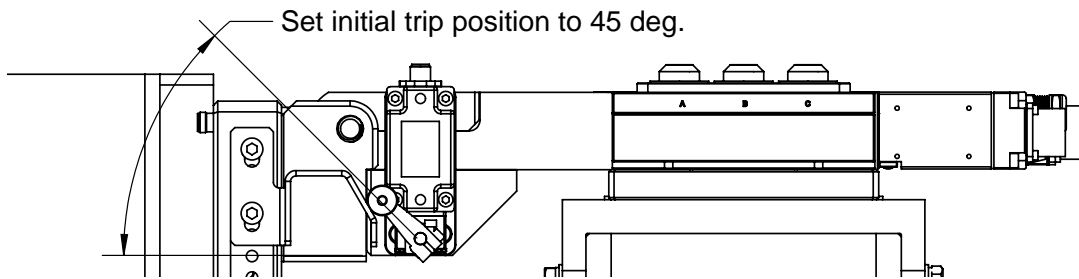
1. Install the switch mounting plate to the tooling interface plate as shown in [Figure 3.12](#).
2. Apply Loctite 242 to the (3) M5 socket flat head cap screws supplied.
3. Secure the mounting plate with the (3) M5 socket flat head cap screws supplied. Tighten to 50 in-lbs (5.65 Nm) using a 4 mm hex key.
4. Install the safety switch to the mounting plate.
5. Apply Loctite 242 to the (4) M5 socket head cap screws supplied with the safety switch.
6. Install the safety switch to the mounting plate with the (4) M5 socket head cap screws using a 4 mm hex key. Tighten to 50 in-lbs (5.65 Nm). Note: The safety switch actuator arm can be repositioned to the desired location refer to the manufacture instruction for repositioning the actuator.
7. Install the adapter plate or the adjustment bar to the hook module. Note: Place a flat washer between the hook module and the adjustment bar. Secure with the (2) M8 socket head cap screws supplied. Tighten to 100 in-lbs (11.3 Nm) using a 6 mm hex key.
8. If the trip dog mounting fasteners do not have pre-applied adhesive, apply Loctite 242 to the (2) M8 socket head cap screws supplied.

**Figure 3.12—Installing a TSI Switch to a Hook Module**



9. Install the trip dog to the adapter plate or adjustment bar, secure with the M8 socket head cap screws using a 6 mm hex key.
10. Position trip dog so that it will actuate the safety switch about 45° with the tooling secure in the Tool Stand. Note: do not actuate the switch more than 75°. Tighten the screws to hold the position.
11. Connect the cable from the safety switch to the Tool side control/signal module.
12. Cycle the Tool pick-up and drop off and adjust the trip dog position. Tighten the (2) M8 socket head cap screws to 100 in-lbs (11.3 Nm) using a 6 mm hex key.

**Figure 3.13—Installing a TSI Switch to a Hook Module**



### 3.5.6 Hook Module with Vertical Tooling Hook Plate or Tool Hook Modules (Non-Contact Euchner Actuator and Switch)

*Tools required:* 3 mm, 4 mm, and 6 mm hex key, torque wrench

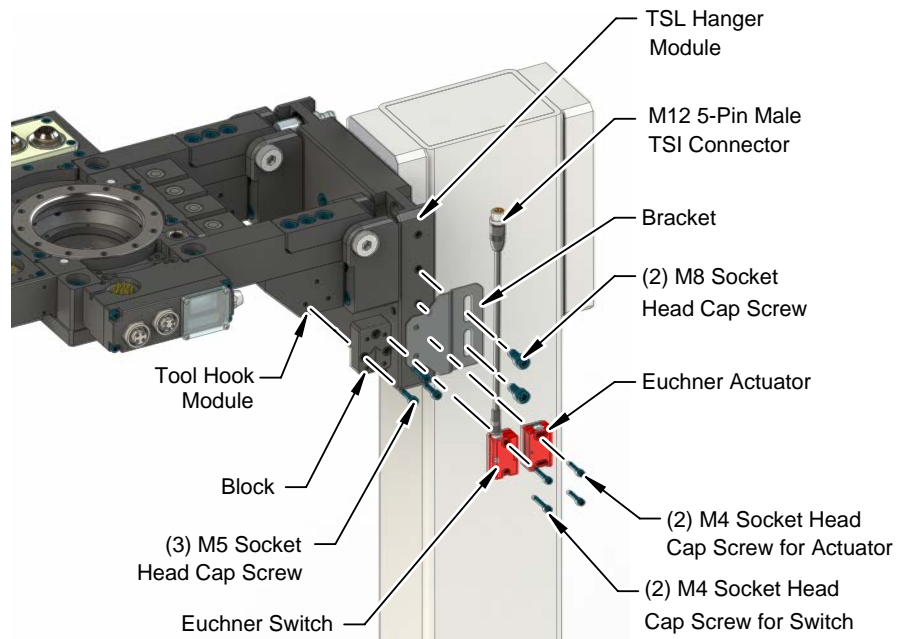
*Parts required:* Loctite 222 and Loctite 242

**NOTICE:** The M4 and M8 socket head cap screws have pre-applied threadlocker. Do not use the threadlocker more than once. Apply Loctite222 or Loctite 242, respectively, to the threads before re-installation.

1. Install the bracket to the TSL hanger module
  - a. Using a 6 mm hex key, secure the bracket to the TSL hanger module with the (2) M8 socket head cap screws. The mounting pattern of the bracket allows for positional adjustment.
  - b. Tighten to 25 in-lbs (2.8 Nm).
2. Install the Euchner actuator to the bracket.
  - a. Using a 3 mm hex key, secure the actuator to the bracket with the (2) M4 socket head cap screws. The mounting pattern of the actuator allows for positional adjustment.
  - b. Tighten to contact plus a quarter turn. Do not over tighten.
3. Install the block to the tool hook module.
  - a. Using a 4 mm hex key, secure the block to the TSL hanger module with the (2) M5 socket head cap screws.
  - b. Tighten to 25 in-lbs (2.8 Nm).
4. Install the Euchner switch to the block.
  - a. Using a 3 mm hex key, secure the switch to the block with the (2) M4 socket head cap screws. The mounting pattern of the actuator allows for positional adjustment.
  - b. Tighten to contact plus a quarter turn. Do not over tighten.

5. Connect the M12 connector on the Euchner switch cable to the TSI connector on the Tool control/signal module.

**Figure 3.14—Install a Non-Contact Euchner Switch to a Hook Module**



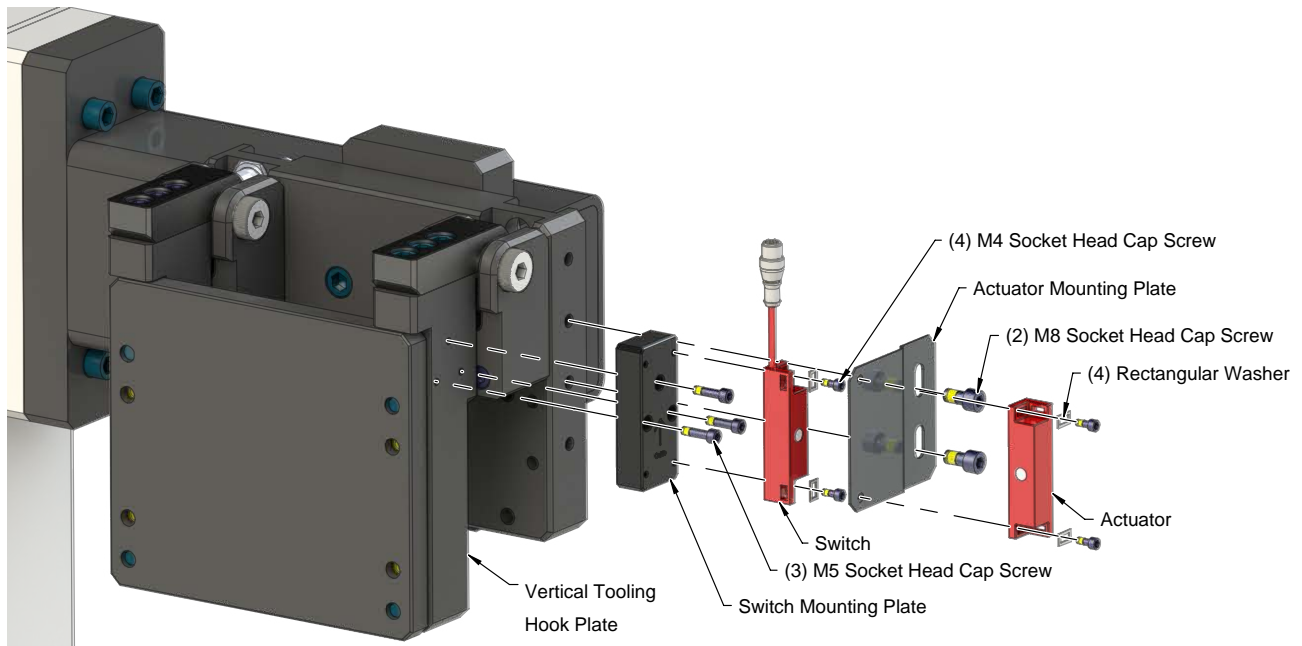
6. Cycle the Tool pick-up and drop off and adjust to the desired position.

### 3.5.7 Hook Module with Vertical Tooling Hook Plate or Tool Hook Modules (Sipha Switch)

*Tools required: 3 mm, 4 mm, and 6 mm hex key , torque wrench*

1. Install the switch mounting plate to the mounting module as shown in [Figure 3.15](#).
2. Secure the switch mounting plate with the (3) M5 socket flat head cap screws supplied. Tighten to 25 in-lbs (2.8 Nm) using a 4 mm hex key.
3. Install the safety switch to the switch mounting plate with the (2) M4 socket head cap screws with rectangular washers. Note: The safety switch actuator can be repositioned to the desired location. Tighten to 8.85 in-lbs (1 Nm) using a 3 mm hex key.
4. Install the actuator mounting plate to the hook module. Secure with the (2) M8 socket head cap screws supplied. Note: The actuator mounting plate can be repositioned to the desired location. Tighten to 25 in-lbs (2.8 Nm) using a 6 mm hex key.
5. Install the actuator to the actuator mounting plate with the (2) M4 socket head cap screws with rectangular washers. Note: The actuator can be repositioned to the desired location. Tighten to 8.85 in-lbs (1 Nm) using a 3 mm hex key.

**Figure 3.15—Install a Sipha Switch to a Hook Module**



6. Connect the cable from the safety switch to the Tool side control/signal module.
7. Cycle the Tool pick-up and drop off and adjust to the desired position.

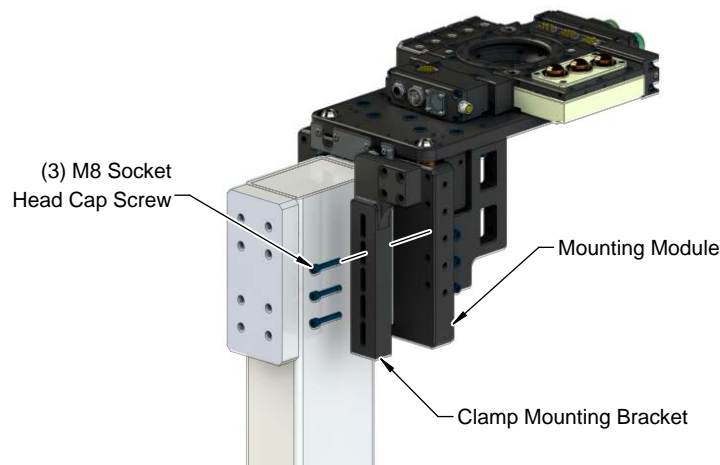
### 3.6 Installing a Debris Shield

**Tools required:** 3 mm, 5 mm, and 6 mm hex key, torque wrench

**Supplies required:** Loctite 222

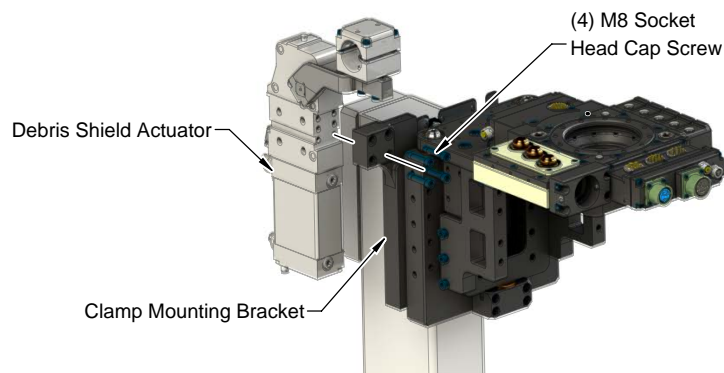
1. Install a shield offset plate, if applicable:
  - a. Attach the shield offset plate to the mounting module with the (4) M8 socket head cap screws (supplied) using a 6 mm hex key. Tighten to 250 in-lbs (28.25 Nm).
2. Install the clamp mounting bracket (refer to [Figure 3.16](#)):
  - a. Attach the bracket to the mounting module or shield offset plate with the (3) M8 socket head cap screws (supplied) using a 6 mm hex key. Do not tighten the fasteners.
  - b. Adjust the clamp mounting bracket so that when the debris shield is installed there will be clearance between the Tool Changer Tool plate and the metal sides of the debris shield.
  - c. Finger tighten the fasteners; after shield is set to the proper height, then these fasteners are tightened to a proper torque.

**Figure 3.16—Installation of Clamp Mounting Bracket**



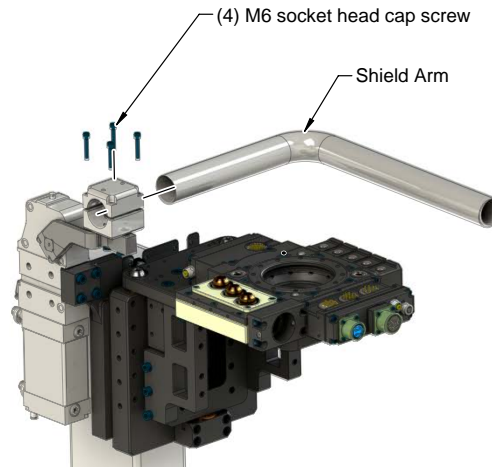
3. Install the debris shield actuator (refer to [Figure 3.17](#)):
  - a. Attach the debris shield actuator to the clamp mounting bracket with the supplied (4) M8 socket head cap screw using a 6 mm hex key. Tighten to 250 in-lbs (28.25 Nm).
  - b. Make sure the (2) M6 set screws in the clamp on the actuator are loose enough to allow the shield arm to slide into the clamp.

**Figure 3.17—Installation of the Debris Shield Actuator**



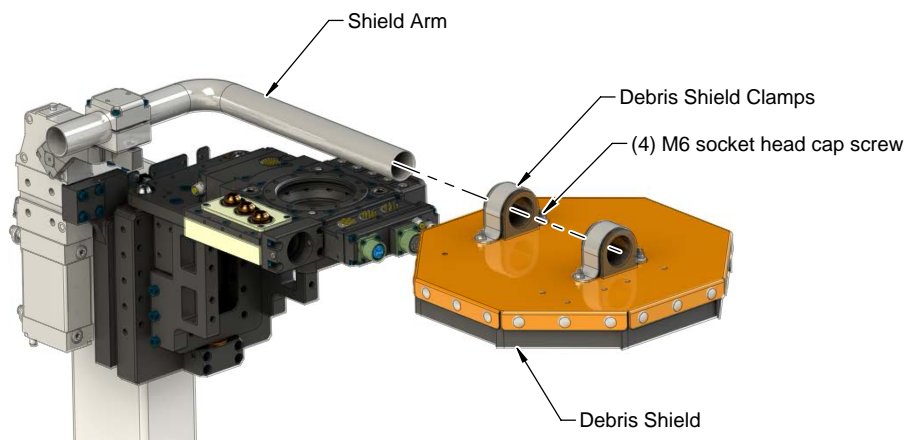
4. Insert the shield arm into the clamp on the debris shield actuator (refer to [Figure 3.18](#)):
  - a. Using a 5 mm hex key, remove the (4) M6 socket head cap screws and apply Loctite 222 and replace screws.
  - b. Finger tighten the (4) M6 socket head cap screws so that the shield arm can slide in the and out.

**Figure 3.18—Installation of the Shield Arm**



5. Install the debris shield on the shield arm (refer to [Figure 3.19](#)):
  - a. Remove the (4) M6 socket head cap screws holding the debris shield clamps to the debris shield, apply Loctite 222 and replace the screws. Leave the clamps loose.
  - b. Slide the debris shield on the shield arm. Adjust the debris shield and shield arm so that the shield is centered above the Tool Changer Tool plate as shown in [Figure 3.20](#).

**Figure 3.19—Installation of a Debris Shield**

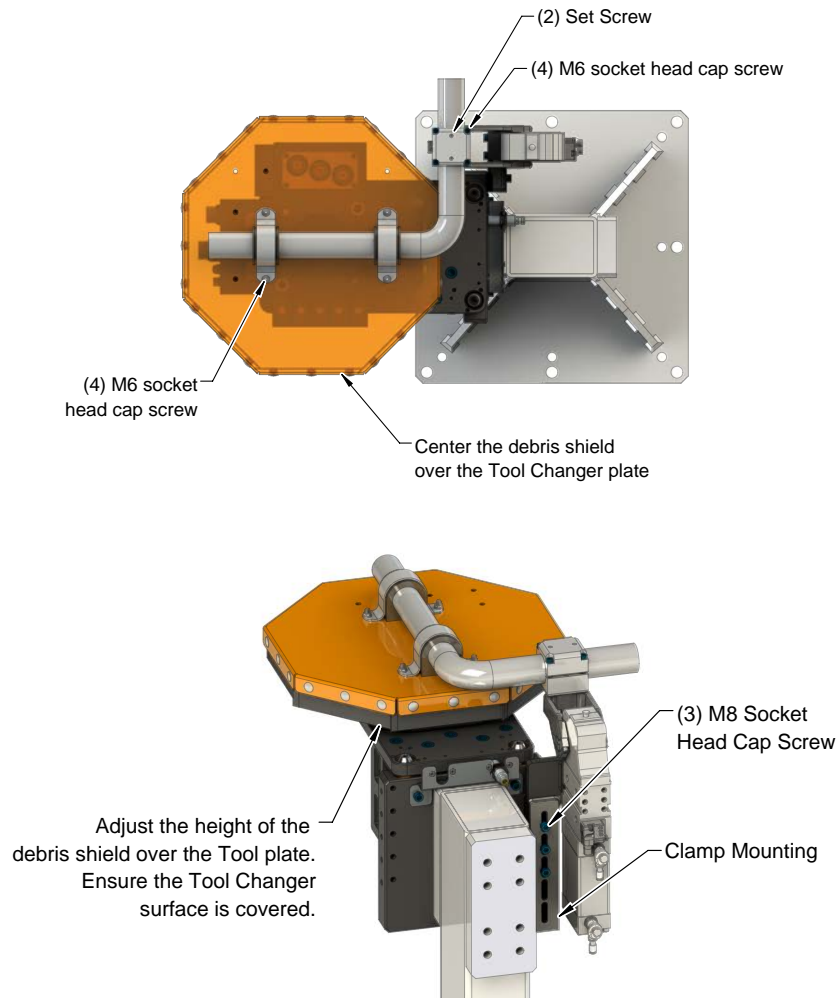


6. Go back to the following loose fasteners, apply loctite, and tighten:
  - a. Tighten the (4) M6 socket head cap screws on the clamp holding the shield arm to the actuator clamp using a 5 mm hex key (refer to [Figure 3.18](#)).
  - b. Tighten the (4) M6 socket head cap screws on the (2) clamps holding the debris shield to the shield arm with a 5 mm hex key (refer to [Figure 3.19](#)).
  - c. Remove the (2) M6 set screws from the clamp on the actuator and apply Loctite 222 and replace. Tighten to 25 in-lbs (2.8 Nm) with a 3 mm hex key (refer to [Figure 3.20](#)).

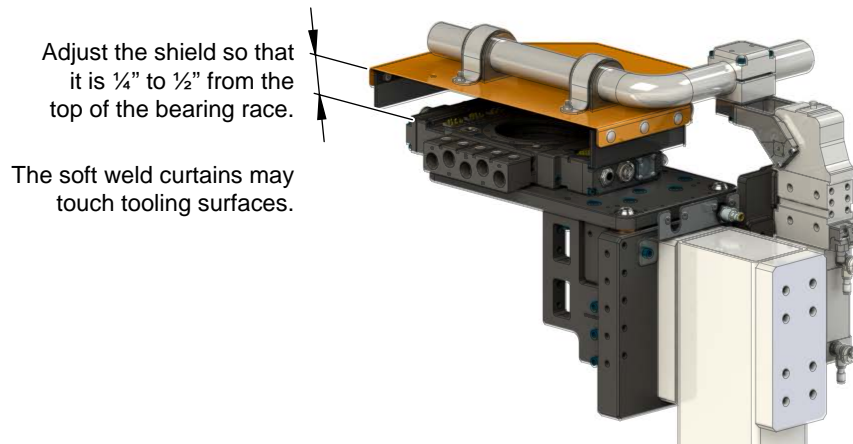


7. Adjust the debris shield height.
  - a. Loosen the (3) M8 socket head cap screws (refer to [Figure 3.16](#)) that hold the clamp mounting and actuator to the mounting module or shield offset using a 6 mm hex key.
  - b. Adjust the debris shield height so that it is ¼” to ½” above the tool assembly plate bearing race (refer to [Figure 3.21](#)).
  - c. Tighten the (3) M8 socket head cap screws (refer to [Figure 3.16](#)) that hold the clamp mounting and actuator to the mounting module or shield offset to 250 in-lbs (28.25 Nm) with a 6 mm hex key.

**Figure 3.20—Adjust Debris Shield**

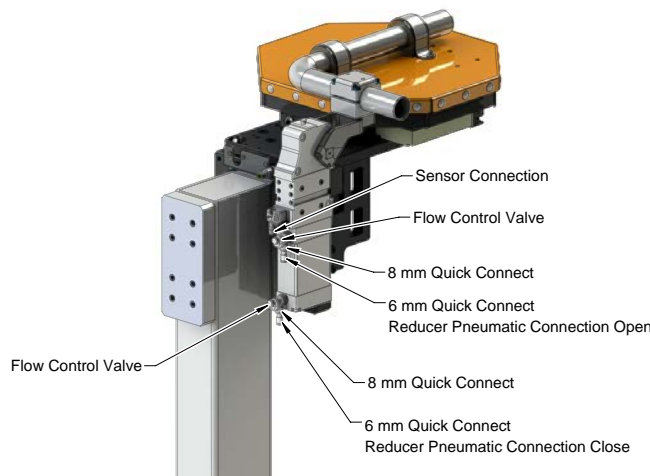


**Figure 3.21—Adjustment Range**



8. Connect the open and close pneumatic lines to the actuator (refer to [Figure 3.22](#)). Any additional valve required for operating the actuator is supplied by the customer (refer to [Section 8.3.1—Debris Shield Actuators Specifications](#)).
9. Connect the cable(s) to the actuator sensor(s). Cabling and line termination is supplied by the customer (refer to [Section 8.3.1—Debris Shield Actuators Specifications](#)).
10. Cycle the debris shield and adjust as necessary. Note: Verify that the TSL debris shield actuates open and closed freely and without interference from the robot dressing or other objects.
  - (Optional) Adjust the debris shield opening angle (refer to the applicable drawing that is referenced in [Section 2.3.3—DSA \(Debris Shield Actuator\)](#)).
11. Adjust the flow controls:
  - a. Start with flow control valve closed.
  - b. Open 1/4 turn.
  - c. Cycle the actuator.
  - d. Adjust the flow control valves as desired.

**Figure 3.22—Pneumatic and Sensor Connections**



12. Verify that the tool path does not interfere with the debris shield, when the shield is open.

### 3.7 Installing a Post-mounted Tool Support and Post Support Roller

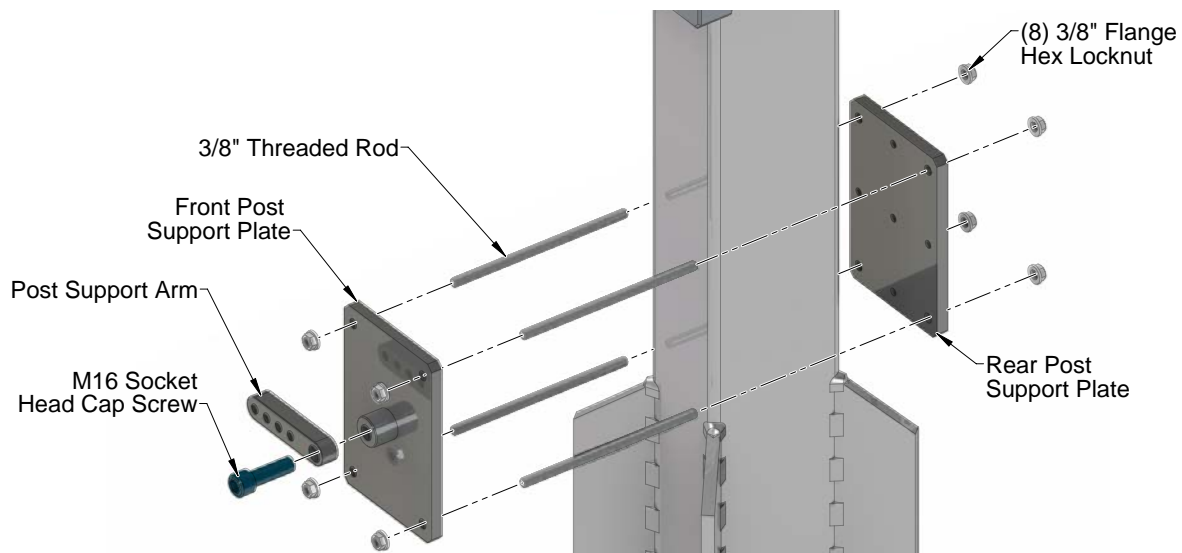
*Tools required:* 14 mm hex key, 9/16 wrench, torque wrench

*Supplies required:* Loctite 242

**NOTICE:** Do not tighten all the nuts on the rod at the same time. Alternate tightening each rod a little at a time until all are tighten to the proper torque.

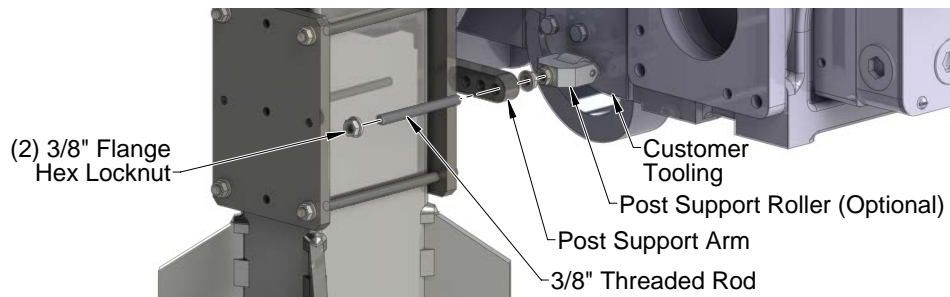
1. Assemble the rear post support plate, front post support plate, and (4) 3/8" threaded rods as shown in [Figure 3.23](#).
  - a. Thread (8) 3/8 flange hex locknuts on the ends of the threaded rods. Tighten to 400 in-lbs (45.19 Nm) using a 9/16 wrench.
2. Attach the post support arm to the front post support plate.
  - a. Apply Loctite 242 to the M16 socket head cap screw.
  - b. Attach the post support arm to the front post support plate the M16 socket head cap screw using a 14 mm hex key.
  - c. Position the arm.
  - d. Tighten the M16 socket head cap screw to 150 ft-lbs (203.37 Nm).

**Figure 3.23—Installing a Post-Mounted Tool Support**



3. Install the bump stop or optional post support roller to the threaded rod.
  - a. Attach the bump stop or optional post support roller to the end of the threaded rod and secure with a 3/8" flange hex locknut, using a 9/16 wrench. Tighten to 400 in-lbs (45.19 Nm).
  - b. Thread a 3/8" flange hex locknut on the threaded rod and insert the threaded rod through the post support arm as shown in [Figure 3.24](#).
  - c. With the tooling supported in the Tool Stand, set the bump stop or optional post support roller against the tooling.
  - d. Thread a 3/8" flange hex locknut on the threaded rod and tighten to 400 in-lbs (45.19 Nm) using a 9/16 wrench.

**Figure 3.24—Installing a Post-Mounted Tool Support and Post Support Roller**



## 4. Operation

Only use the TSL system with No-touch locking Tool Changers only, such as ATI changers QC-160 and larger.

### 4.1 Tips for Programming the Tool Changer

- Jog the robot so that TSL tooling interface plate is directly above the mounting module on the post module.
- Carefully lower the TSL tooling interface plate toward the mounting module so that the post locating pins are centered in the plate bushings.
- When the pins and bushings are nearly touching, adjust the robot position so that the Tool with interface plate is nearly parallel to the post module. Be careful not to bind the alignment pins during this procedure.
- Carefully jog the robot downward vertically, until all three pins and bushings are fully engaged and distance between the mounting module and the tooling interface plate is less than the maximum tool drop off of 3 mm (0.118").
- Record this position as the drop off point. Note: This can be used as an initial pick up point as well but may have to be adjusted depending on the deflection caused by the weight of the tooling.
- If equipped, make sure the TSI switch is tripped and proximity sensor indicates Tool is in the stand.
- If dropping off the Tool, adjust the robot payload to remove the weight of the tooling.
- Move the robot up vertically making sure the Tool with interface plate are nearly parallel to the post module until the tool is completely clear of the TSL debris shield envelope, and record this position as clear of the Tool Stand.

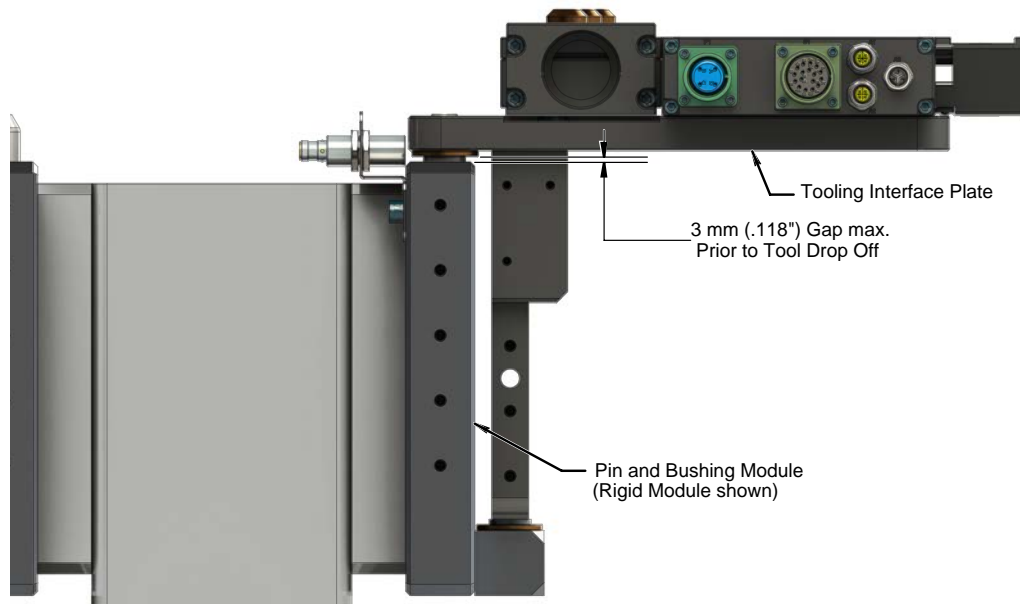
### 4.2 TSL System with Pin and Bushing Style Mounting Operation



**CAUTION:** Damage will occur if contact is made between the TSL pin and bushing tooling plate and the mounting module prior to tool drop-off.

For Tool drop-off, ATI recommends 3 mm (0.118") maximum clearance between TSL pin and bushing mounting module contact surfaces and the TSL tooling interface plate contact surface (refer to [Figure 4.1](#)).

**Figure 4.1—Maximum Clearance for Proper Tool Drop-off for Pin and Bushing Style Mounting**



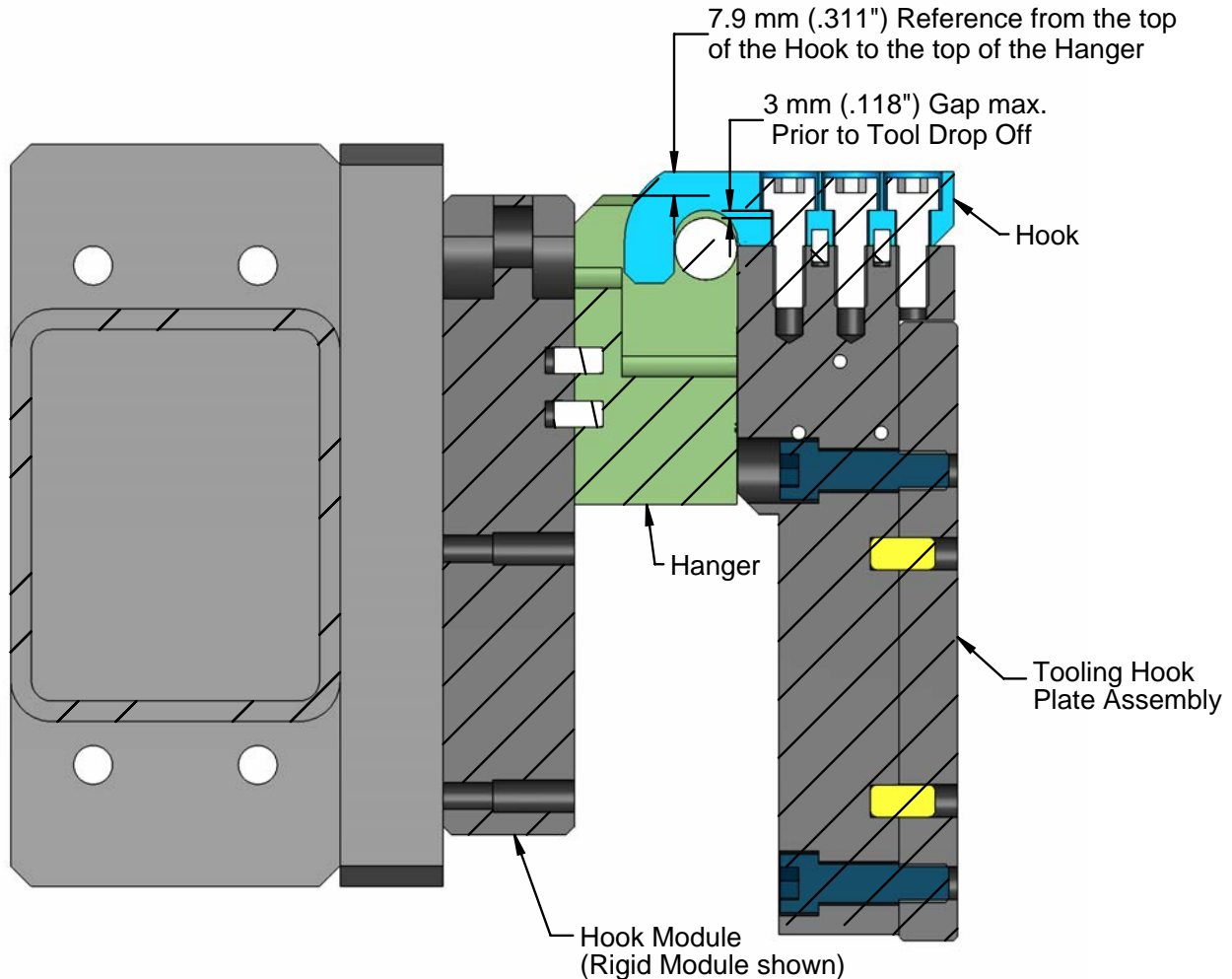
### 4.3 TSL System with Hook Style Mounting Operation



**CAUTION:** Damage will occur if contact is made between the TSL tooling hook plate and the mounting module prior to tool drop-off

For Tool drop-off, ATI recommends 3 mm (0.118") maximum clearance between the hook mounting module contact surfaces and the tooling hook plate contact surface. The reference dimension is shown for ease measurement, 7.9 mm (0.311") maximum from the top of the hook to the top of the hanger. See [Figure 4.2](#) for reference.

**Figure 4.2—Maximum Clearance for Proper Tool Drop-off for Hook Style Mounting**



## 5. Maintenance



**WARNING:** Do not perform maintenance or repair(s) on the Tool Changer or modules unless the Tool is safely supported or placed in the tool stand, all energized circuits (for example: electrical, air, water, etc.) are turned off, pressurized connections are purged and power is discharged from circuits in accordance with the customer specific safety practices and policies. Injury or equipment damage can occur with the Tool not placed and energized circuits on. Place the Tool in the tool stand, turn off and discharge all energized circuits, purge all pressurized connections, and verify all circuits are de-energized before performing maintenance or repair(s) on the Tool Changer or modules.

### 5.1 Preventative Maintenance

Check the following areas at least once every 5,000 cycles. Earlier intervention is necessary if a problem is identified prior to the scheduled maintenance checks.

#### 5.1.1 All TSL Systems

- Inspect that post module base plate anchor bolts are secure to the floor.
- Inspect all hoses and utility lines for wear. If worn, repair or replace.
- Verify horizontal extensions, pin and bushing modules, and hook modules are not loose. If loose, apply new threadlocker and tighten mounting fasteners as specified in [Section 3.1—Installing the Post Module, Pin and Bushing or Hook and Hanger Module](#).
- Inspect all extensions and tooling plates for signs of sagging or deflection; if so, contact ATI.
- Inspect all steel components for rust; some steel components have a black oxide finish, for example: trip dogs and mounting hooks. If needed, clean and lubricate with a brush and M1 oil. For wet or humid environments, inspect more frequently.
- (If equipped) check that all sensor module mounting fasteners are tight. If loose, apply new threadlocker and tighten fasteners. Check that the proximity sensor is not loose and is correctly positioned; adjust and tighten, if required (refer to [Section 3.3—Install a Sensor Module to a Pin and Bushing Module](#)).
- (If equipped) inspect and wipe clean all proximity sensor faces.
- (If equipped) check that all TSI switch assembly mounting fasteners are not loose. If required apply Loctite and tighten fasteners. Check that the TSI switch is adjusted properly; adjust and tighten if required (refer to [Section 3.5—Installation of a Tool Stand Interlock \(TSI\) Switch Assembly](#)).
- (If equipped) check that the fasteners are not loose for the debris shield, shield arm, and debris shield actuator. If loose, apply threadlocker and tighten fasteners. Check debris shield operation and adjust, if necessary (refer to [Section 3.6—Installing a Debris Shield](#)).
- (If equipped) check that the fasteners are not loose for post support and post support roller. If loose, apply Loctite and tighten fasteners (refer to [Section 3.7—Installing a Post-mounted Tool Support and Post Support Roller](#)).

#### 5.1.2 TSL Systems with Pin and Bushing Style Mounting Modules

- Clean and lubricate the pin and bushing module. Check the (3) alignment pins for looseness, wear, or damage. If loose apply Loctite and tighten, if worn or damaged replace. Check the (3) Alignment bushing for wear and damage. If worn or damaged replace. Refer to [Section 5.1.4.1—Clean, Lubricate, and Replace Alignment Pins and Bushings](#) for details.

### 5.1.3 TSL Systems with Hook and Hanger Style Mounting Modules

- Check the (2) shoulder bolts for looseness, wear, and damage. If loose apply Loctite and tighten, if worn or damaged replace. Check the (2) hooks for looseness, wear and damage. If loose tighten the (3) M10 socket head cap screws, if worn or damaged replace. Refer to [Section 5.1.4.2—Inspect, Tighten, and Replace Shoulder Bolts and Hook Attachments](#).

### 5.1.4 Preventive Maintenance Procedures

Maintenance procedures help prevent downtime on an active assembly line; these procedures are in the following sections.

#### 5.1.4.1 Clean, Lubricate, and Replace Alignment Pins and Bushings

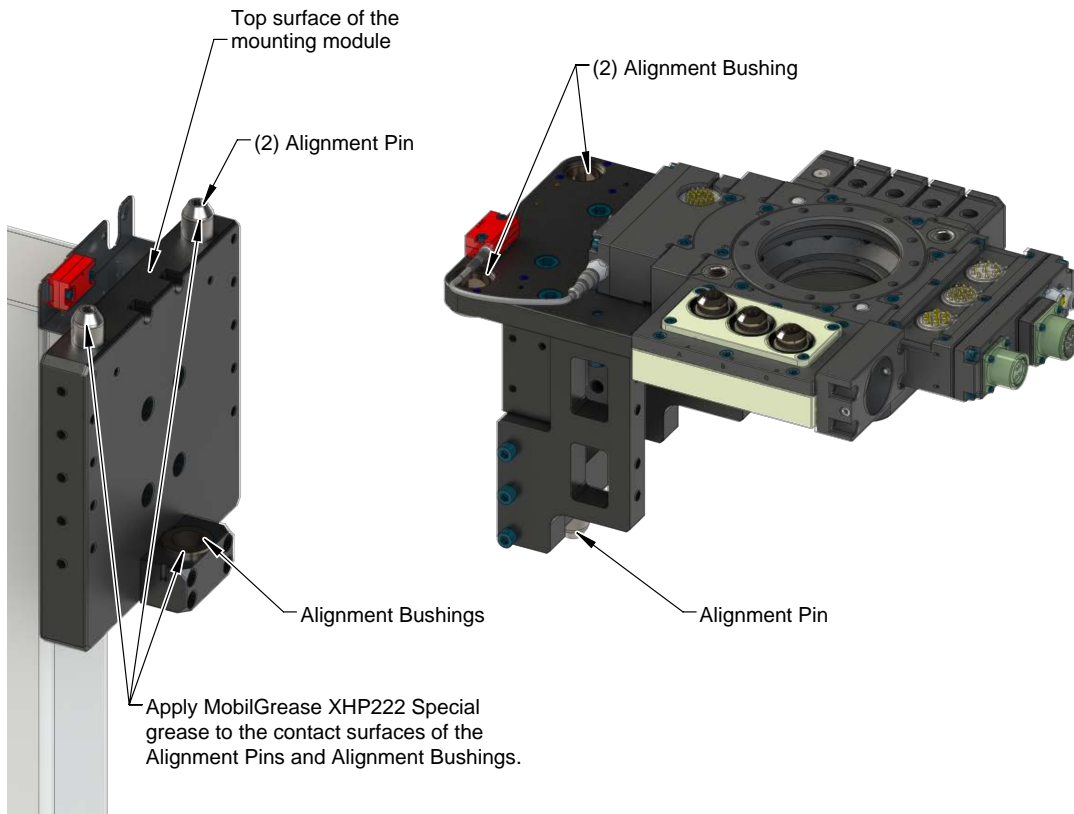
**Parts required:** See the drawings referenced in [Section 2.1—TSL System with Pin and Bushing Style Mounting](#).

**Tools required:** 8 mm hex key, 9/16 wrench, torque wrench

**Supplies required:** Clean rag, Loctite 7649 Primer, Loctite 242, MobilGrease® XHP222 Special grease

1. Remove the Tool from the Tool Stand.
2. Use a lint free rag to remove debris from the following components:
  - alignment pins
  - alignment bushing
  - top surface of the mounting module
  - (2) bushings and alignment pin in the tooling interface plate shown in [Figure 5.1](#).

**Figure 5.1—Clean and Lubricate the Alignment Pins and Alignment Bushings**





3. Inspect the (3) alignment pins for looseness, wear, or damage.
  - a. If worn or damaged remove, discard, and replace with new alignment pin:
    - i. Apply Loctite 7649 and 242 to the threads of the new pin and thread into the mounting module. Tighten to 250 in-lbs (28.25 Nm) using an 8 mm hex key.
  - b. If loose, tighten:
    - i. Remove the pin and apply Loctite 7649 and 242 to the threads.
    - ii. Thread the pin into the mounting module. Tighten to 250 in-lbs (28.25 Nm) using an 8 mm hex key.
4. Inspect the (3) alignment bushings for wear or damage; if worn or damaged, replace:
  - a. Press out old bushing using an arbor press.
  - b. Press in the new bushing.
5. Apply liberal amounts of MobilGrease XHP222 Special grease to the alignment pins and the alignment bushing on the mounting module (refer to [Figure 5.1](#)).
6. Place the Tool in the Tool Stand.

### 5.1.4.2 Inspect, Tighten, and Replace Shoulder Bolts and Hook Attachments

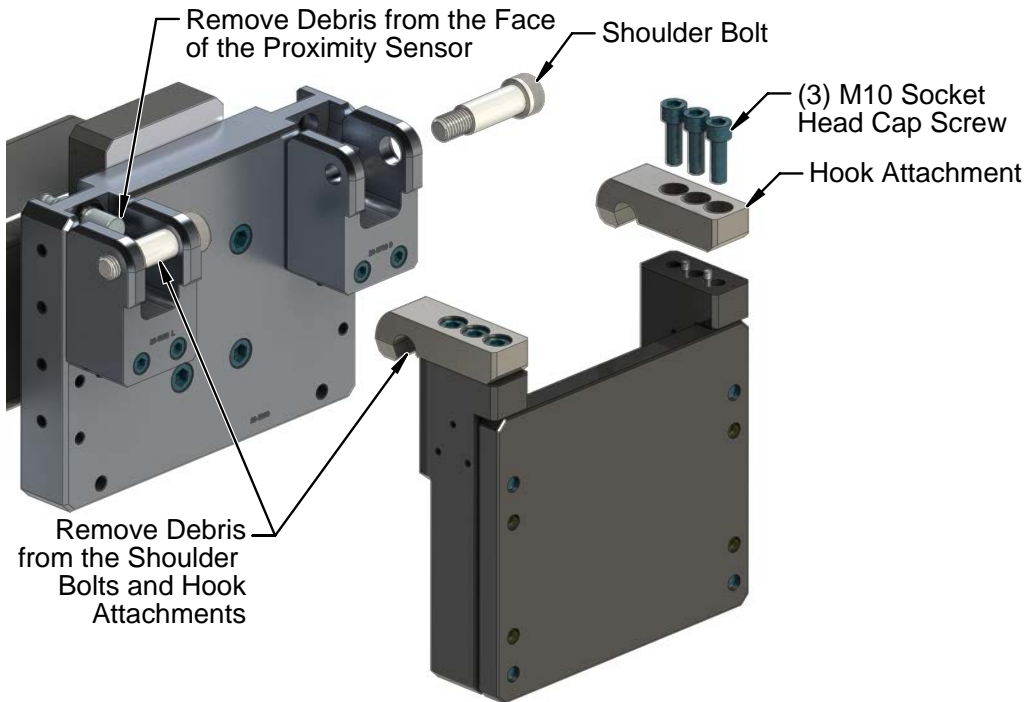
**Parts required:** See the drawings referenced in [Section 2.2—TSL System with Hook and Hanger Style Mounting](#).

**Tools required:** 8 mm and 3/8 hex key, torque wrench

**Supplies required:** Clean rag, Loctite 242

1. Remove the Tool from the Tool Stand.
2. Using a lint free rag, remove debris from the shoulder bolts, hook attachments, and the face of the proximity sensor.
3. Inspect the (2) shoulder bolts in the mounting module for looseness, wear or damage.
  - a. If worn or damaged remove, discard, and replace with new shoulder bolt. Apply Loctite 242 to the threads of the new shoulder bolt and thread into the mounting module. Tighten to 50 in-lbs (5.65 Nm) using a 3/8 hex key.
  - b. If loose, remove and apply Loctite 242 to the threads. Thread into the mounting module. Tighten to 50 in-lbs (5.65 Nm) using a 3/8 hex key.
4. Inspect the (2) hook attachments in the tooling interface plate for looseness, wear or damage.
  - a. If worn or damaged, remove the (3) M10 socket head cap screws and remove the hook attachment. Discard and replace with new hook attachment. Assemble the hook attachment to the tooling plate, secure with the (3) M10 socket head cap screws. Tighten to 38 ft-lbs (51.52 Nm) using an 8 mm hex key.
  - b. If loose, tighten the (3) M10 socket head cap screws to 50 in-lbs (5.65 Nm) using an 8 mm hex key.
5. Place the Tool in the Tool Stand.

**Figure 5.2—Inspect, Tighten, and Replace the Shoulder Bolts and Hook Attachments**

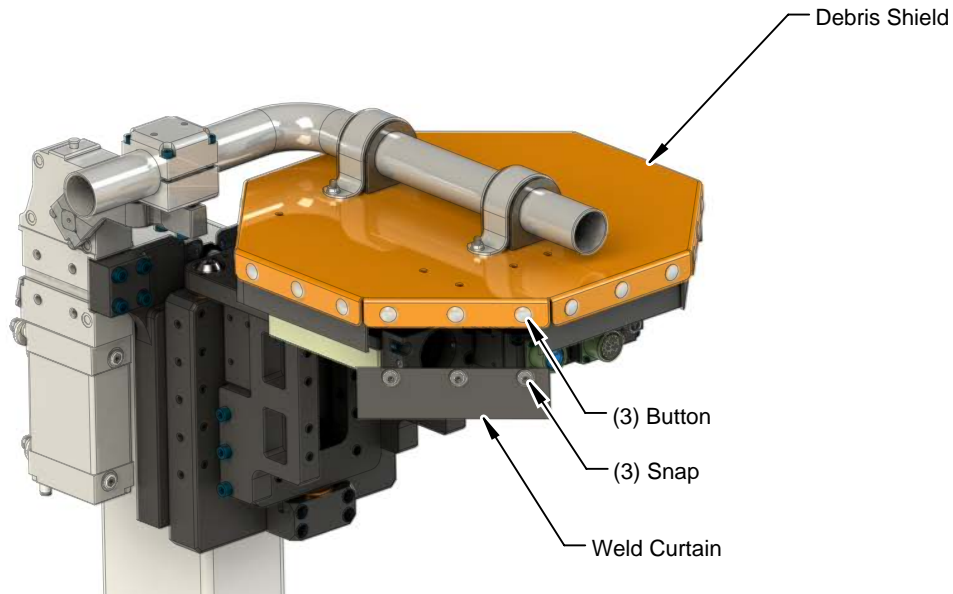


### 5.1.4.3 Inspection and Replacement Procedure for Debris Shield Weld Curtains

*Parts required:* See the drawings referenced in [Section 2.3.4—Debris Shield and Shield Arm](#)

1. Inspect the weld curtain for looseness, wear or damage.
2. If worn or damaged, pull the weld curtain snaps from the buttons on the flange of the debris shield.
3. Discard the weld curtain.
4. With the debris shield snaps, attach the new weld curtain to the buttons on the inside flange of the debris shield.

**Figure 5.3—Weld Curtain Replacement**



## 6. Troubleshooting

For assistance to resolve issues that arise during operation, refer to the following table:

Symptom	Possible Cause	Correction
Tool position while in the storage is not straight and parallel.	Tool alignment pin may be loose, worn, damaged, or missing.	Tighten or replace alignment pins If necessary. Refer to <a href="#">Section 5.1.4.1—Clean, Lubricate, and Replace Alignment Pins and Bushings</a> .
	Alignment bushing may be worn.	Inspect the alignment bushings for wear. Replace If necessary. Refer to <a href="#">Section 5.1.4.1—Clean, Lubricate, and Replace Alignment Pins and Bushings</a> .
	Shoulder bolt may be loose, worn or missing.	Inspect shoulder bolt, tighten or replace If necessary. Refer to <a href="#">Section 5.1.4.2—Inspect, Tighten, and Replace Shoulder Bolts and Hook Attachments</a> .
	Hook attachment may be loose or worn.	Inspect hook attachment, tighten or replace If necessary. Refer to <a href="#">Section 5.1.4.2—Inspect, Tighten, and Replace Shoulder Bolts and Hook Attachments</a> .
Proximity sensor fails	Debris build up on the proximity sensor.	Check for debris build up and clean If necessary.
	Proximity sensor loose or not positioned properly.	Verify that the correct distance between sensing face and target is set. Adjust If necessary. For pin and bushing mounting modules, refer to <a href="#">Section 3.3—Install a Sensor Module to a Pin and Bushing Module</a> . For hook and hanger mounting modules, refer to <a href="#">Section 3.4—Install a Proximity Sensor to a Hook Module</a> .
	Sensor cable broken or damaged.	Inspect sensor cable for damage, test continuity, replace If damaged.
	Proximity sensor damaged or not functioning.	Inspect proximity sensor for damage, test sensor.
Debris shield malfunctioning	Debris shield mounting loose or out of adjustment.	Inspect mounting for looseness, tighten fasteners. Inspect for proper adjustment, adjust If necessary. Refer to <a href="#">Section 3.6—Installing a Debris Shield</a> .
	Debris shield actuator sensor malfunctioning or cables damaged.	Inspect sensor cable for damage, test continuity, replace If damaged. Inspect sensor for damage, test sensor, replace If necessary.
Tool stand interlock switch malfunctioning.	TSI switch or trip dog out of adjustment or loose mounting fasteners.	Inspect TSI switch and trip dog for loose mounting fasteners and adjustment, tighten fasteners or adjust switch and trip dog. Refer to <a href="#">Section 3.5—Installation of a Tool Stand Interlock (TSI) Switch Assembly</a> .
	TSI switch or cable damaged.	Inspect switch cable for damage and test for continuity. If damaged replace. Test switch for functionality; if not functioning, replace.
Tool/ end-effector is malfunctioning.	Utility lines and cables damaged.	Inspect utility lines and cables for damage or wear. Inspect all connections for damage. Test cable continuity. Replace any damaged utility lines and cables.
	Tool Changer or utility modules not functioning properly.	Verify Tool Changer and utility modules for proper function. Refer to the Tool Changer and module Installation and Operation manual for troubleshooting.

## 7. Serviceable Parts

Commonly spare parts for the TSL system are listed in the following table: (other components available upon request)

Model	Part Number	Name
Common Tool Stand Components	8590-9909999-92	PNP Prox Sensor 5 mm sensing Range, 18 mm Barrel, Shielded
Tool Stand with the Pin and Bushing Style Mounting	3700-20-3323	Tool Stand Alignment Pin
	3710-20-1028	Large Tool Stand Bronze Bushing
Tool Stand with the Hook and Hanger Style Mounting	3500-2035175-11	Shoulder Bolt
	3700-20-5697	TSL Hook Attachment

### 7.1 Part Number Cross Reference

A reference of retired part numbers with the current part numbers are listed in the following tables:

#### 7.1.1 TSL Systems with Pin and Bushing Style Mounting

<i>Section 2.1.2—Pin and Bushing Mounting Module</i>		
Current part number	Retired part number	Description
9120-TSL-RMB-R000	9120-TSL-CMB-R000	Pin and Bushing Module, Rigid
<i>Section 2.1.3—Tooling Interface Plates</i>		
9120-TSL-HBB-4115	9120-TSL-TP-4104	Tooling Interface Plate - Blank
9120-TSL-VBB-3328	9120-TSL-TP-3328	Vertical Tooling Interface Plate - Blank

#### 7.1.2 TSL Systems with Hook and Hanger Style Mounting

<i>Section 2.2.2—Hook Mounting Modules</i>		
Current part number	Retired part number	Description
9120-TSL-RMH-R000	9120-TSL-CMH-R000	Hook Module, Rigid

## 8. Specifications

The following weights are prior to custom machining and additional tooling requirements.

### 8.1 Components for TSL Systems with Pin and Bushing Style Mounting

Part description	Part Number	Material	Approximate Weight-Mass
Post Module with (1) Mounting Module, 48"	9120-TSL-PM-148B-R000	Steel weldment with Anodized T-6 Aluminum Mounting Modules	186 lbs
Post Module with (2) Mounting Modules, 48"	9120-TSL-PM-248B-R000	Steel weldment with Anodized T-6 Aluminum Mounting Modules	203 lbs
Pin and Bushing Module, Rigid	9120-TSL-RMB-R000	Anodized T-6 Aluminum	16.8 lbs
Horizontal Tooling Interface Plate - Blank	9120-TSL-HBB-4115	Anodized T-6 Aluminum	15.9 lbs
Vertical Tooling Interface Plate - Blank	9120-TSL-VBB-3328	Anodized T-6 Aluminum	11.0 lbs

### 8.2 Components for TSL Systems with Hook and Hanger Style Mounting

Part description	Part Number	Material	Approximate Weight-Mass
Post Module with (1) Mounting Module, 48"	9120-TSL-PM-148H-R000	Steel weldment with Anodized T-6 Aluminum Mounting Modules	184 lbs
Post Module with (2) Mounting Modules, 48"	9120-TSL-PM-248H-R000	Steel weldment with Anodized T-6 Aluminum Mounting Modules	199 lbs
Hook Module, Rigid	9120-TSL-RMH-R000	Anodized T-6 Aluminum	15.3 lbs
Vertical Tooling Interface Plate - Blank	9121-TSL-TH-5641	Anodized T-6 Aluminum	10.6 lbs
Hook Arm, Right Side, QC-210 Tool Hook Module	9121-NA2-T	Anodized 7075-T6 Aluminum with prehardened 4140 steel hooks	4.43 lbs (2.01 kg)
Hook Arm, Left Side, QC-210 Tool Hook Module	9121-NA3-T		
Hook Arm, 2" Longer, Right Side, Tool Stand Integrated Hook Module	9121-NA4-T	Anodized 7075-T6 Aluminum with prehardened 4140 steel hooks	4.82 lbs (2.19 kg)
Hook Arm, 2" Longer, Right Side, Tool Stand Integrated Hook Module	9121-NA5-T		

### 8.3 Debris Shield Components for TSL Systems

Part description	Material	Weight-Mass
Debris Shield Actuator - Horizontal - 135°	Steel weldment	42.0 lbs
Debris Shield Actuator - Vertical - 135°	Steel weldment	11.5 lbs
Horizontal Extension, 12", 90°	Steel weldment	40.4 lbs

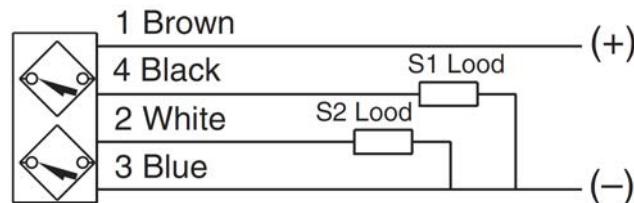
#### 8.3.1 Debris Shield Actuators Specifications

Part Number	9120-TSL-DSA-135-7487	9120-TSL-DSA-135-7486
Actuation (adjustable)	Horizontal - 135°	Vertical - 135°
Max. Operating pressure	116 psi	
Min. Operating pressure	44 psi	
Min Operating time	1.0 second to open, 1.0 second to close	
Pneumatic Ports	Pneumatic Ports 6 mm quick connect	
Sensing Positions	Open and closed	
Sensor Output	N.O. <sup>1</sup> , PNP	
Sensor Supply Voltage	10 to 30VDC	
Sensor Current Load	≤150 mA	

Notes:

1. N.O. is normally open or that the switch is normally open.

Figure 8.1—Debris Shield Sensor Wiring Diagram



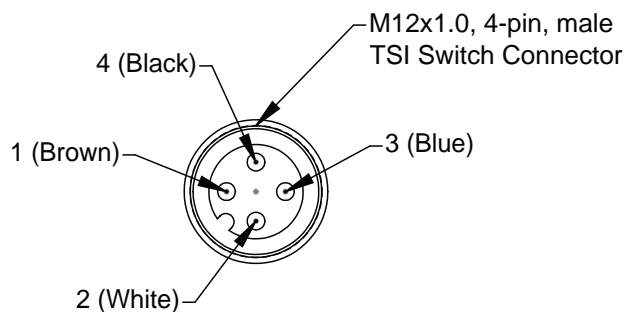
### 8.4 TSI Euchner Contact Switch Electrical Specifications

Table 8.1—TSI Euchner Contact Switch Electrical Specifications		
Pin Number (refer to <a href="#">Figure 8.2</a> )	Wire Color (refer to <a href="#">Figure 8.2</a> )	Contact Type (Group)
1	Brown	N.O. <sup>1</sup> (Pin 1 and 4)
2	White	N.O. <sup>1</sup> (Pin 2 and 3)
3	Blue	N.O. <sup>1</sup> (Pin 2 and 3)
4	Black	N.O. <sup>1</sup> (Pin 1 and 4)

Notes:

1. N.O. is normally open or that the switch is normally open.

Figure 8.2—M12 TSI Connector on the Euchner Switch



## 9. Drawings

Drawings are available on the [ATI website](#) or by contacting an ATI representative.