

REV.	DESCRIPTION	INITIATOR	DATE
01	INITIAL DRAWING	BRR	8/22/2019

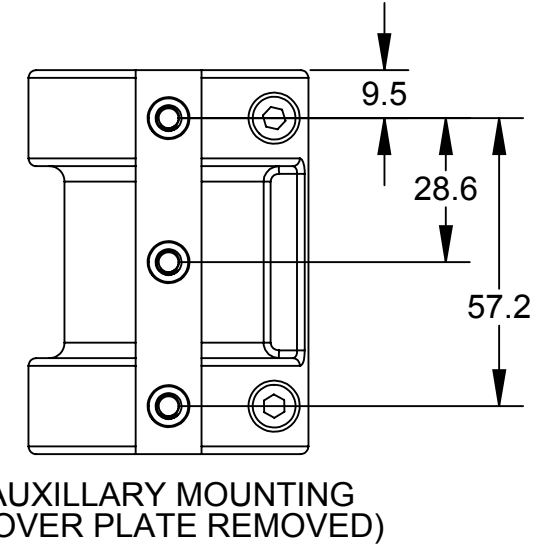
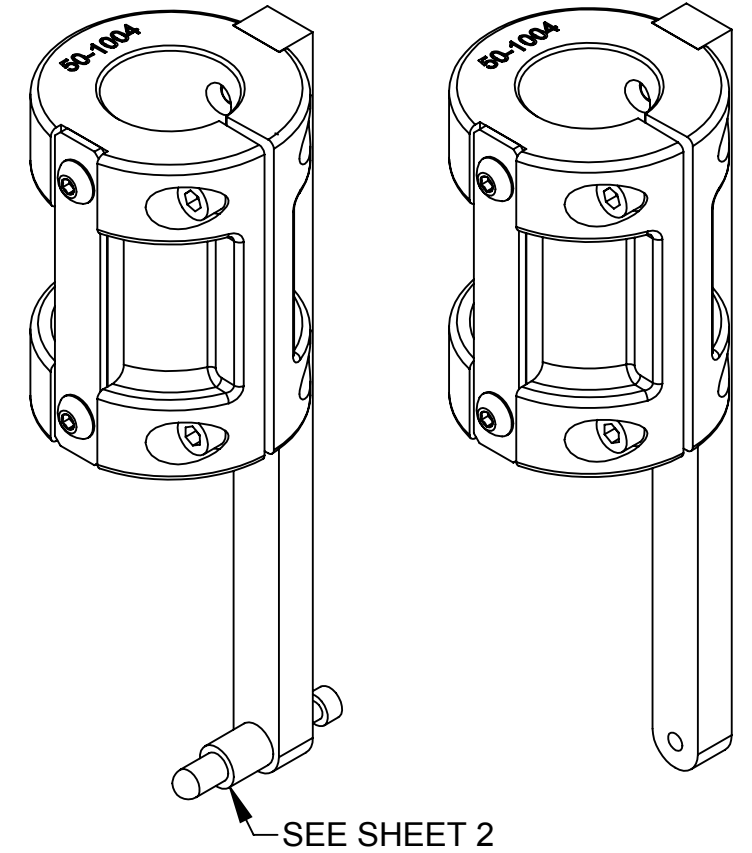
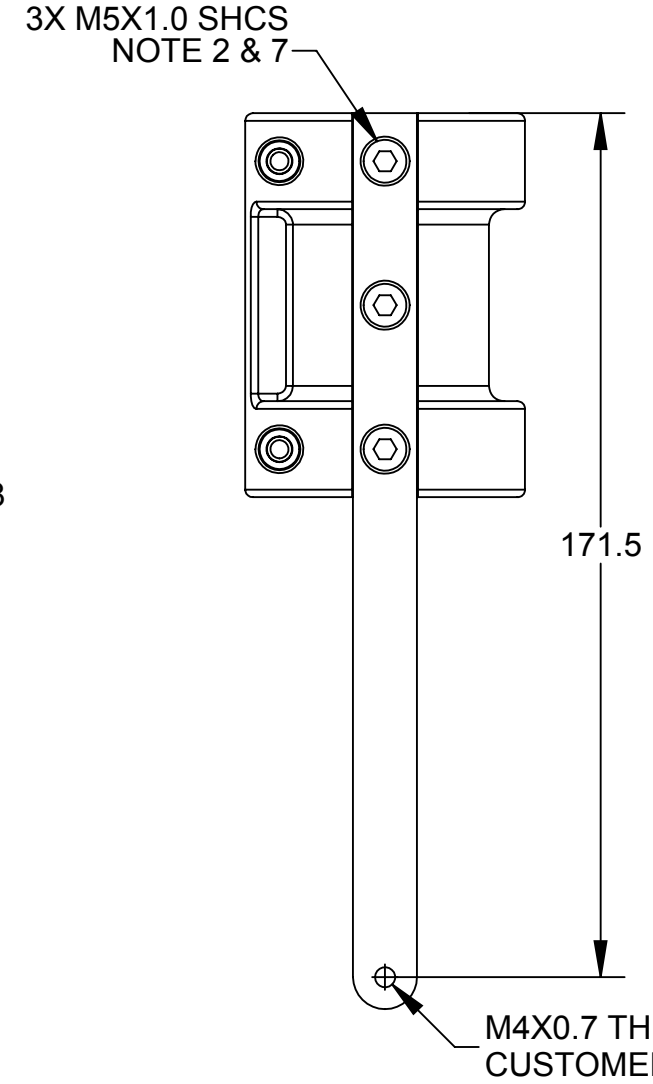
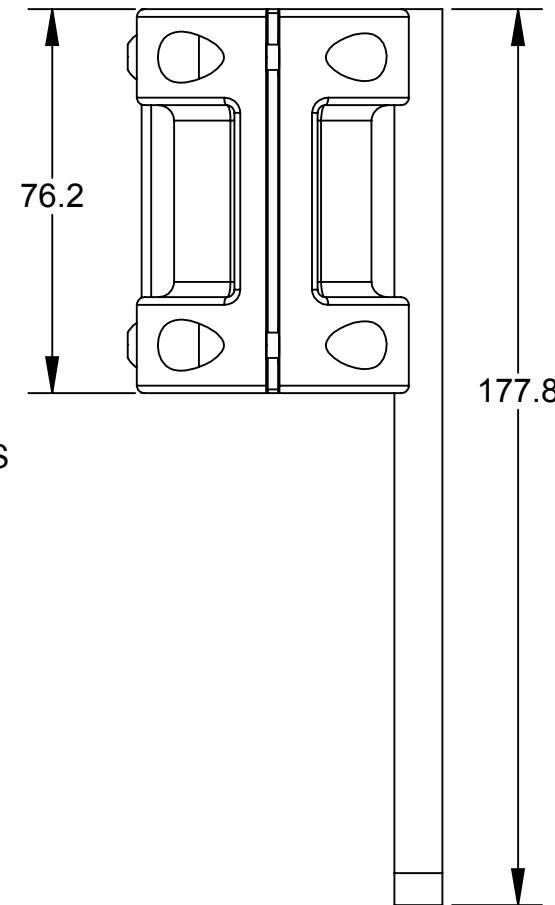
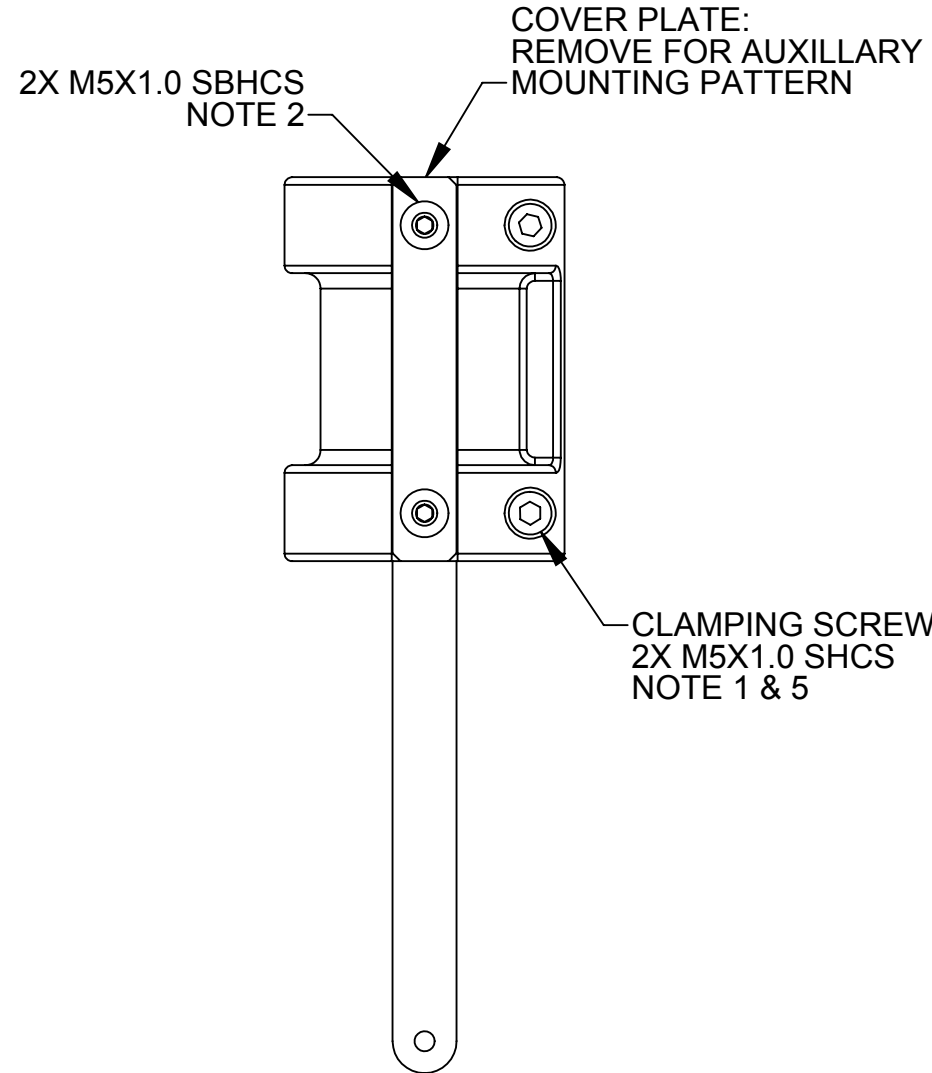
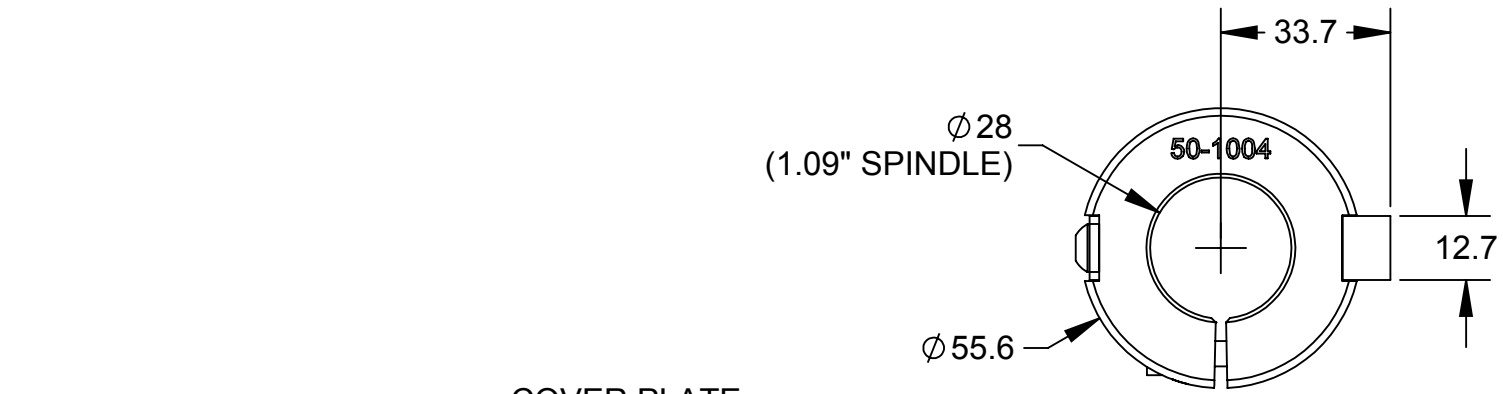

- Notes:
1. CLAMPING SCREWS TO BE TORQUED TO 6IN-LBS WHEN INSTALLING ON TOOL.
  2. IF REMOVED, APPLY LOCTITE 222 OR EQUIVALENT AND TORQUE TO 15IN-LBS.
  3. DUST BELLOWS TO BE REMOVED FOR PROPER CLAMP INSTALLATION.
  4. COMPATIBLE WITH ALL RCV-390 MODELS.
  5. ITEMS SHIP LOOSE WITH UNIT.
  6. APPLY LOCTITE 222 OR EQUIVALENT TO INTERNAL M4 THREADED INSERT.
  7. ALL M5 SHCS HOLDING ALUMINUM ARM TO CLAMP MUST BE PROPERLY INSTALLED THRU BAR AT ALL TIMES.

NOTES: UNLESS OTHERWISE SPECIFIED.

DO NOT SCALE DRAWING. ALL DIMENSIONS ARE IN MILLIMETERS.

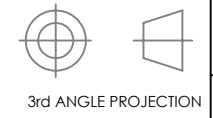

1031 Goodworth Drive, Apex, NC 27539, USA  
 Tel: +1.919.772.0115 www.ati-ia.com  
 Fax: +1.919.772.8259 ISO 9001 Registered Company

PROPERTY OF ATI INDUSTRIAL AUTOMATION, INC. NOT TO BE REPRODUCED IN ANY MANNER EXCEPT ON ORDER OR WITH PRIOR WRITTEN AUTHORIZATION OF ATI.

DRAWN BY: B. Rose - 6/27/2019		TITLE	
CHECKED BY: D. Bohle - 7/16/2019		Profile Follower Customer Drawing, 1.09" Spindle Mount	
SCALE	SIZE	DRAWING NUMBER	REVISION
2:3	B	9630-50-RC-A-PF2	01
PROJECT # 180507-1		SHEET 1 OF 2	

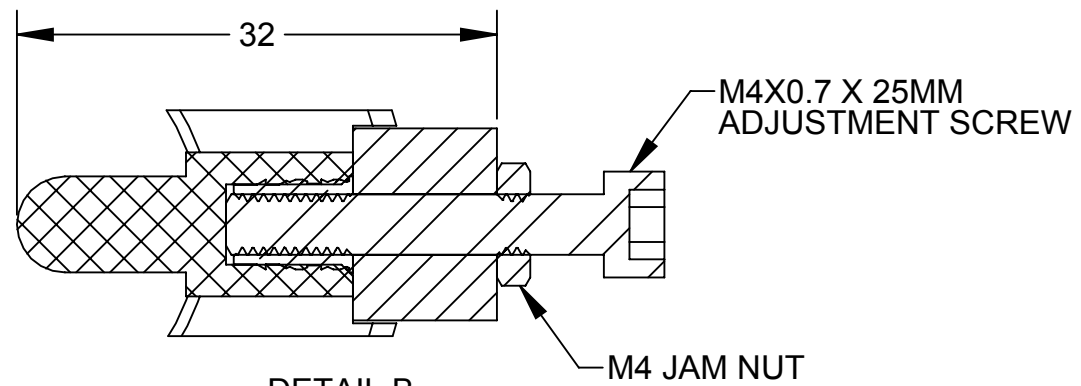
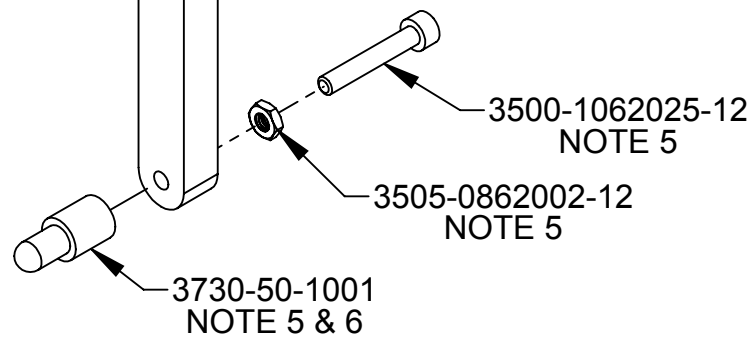
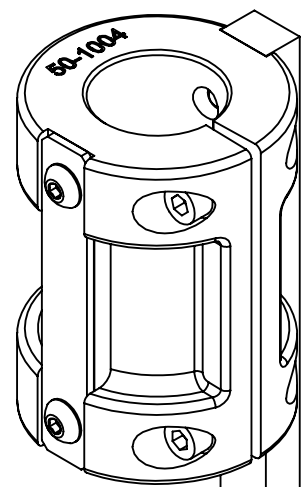

DETAIL B  
SCALE 2 : 1

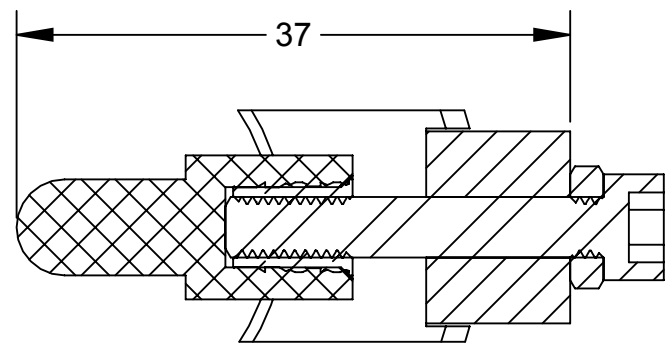

DETAIL D  
SCALE 2 : 1  
FOLLOWER TIP SHOWN FULLY ADJUSTED

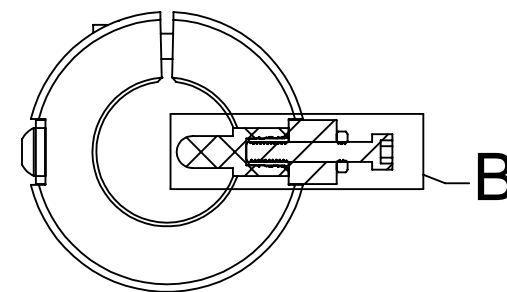
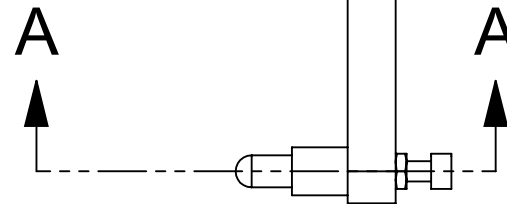
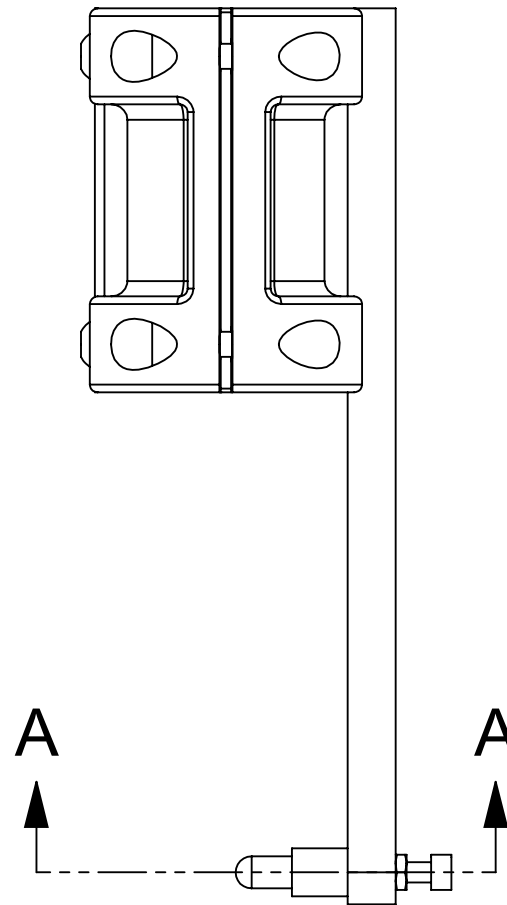

SECTION A-A

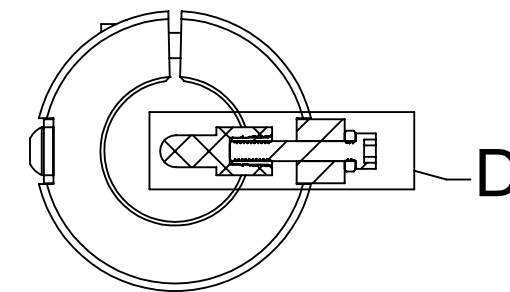
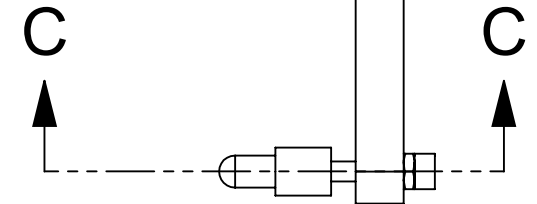
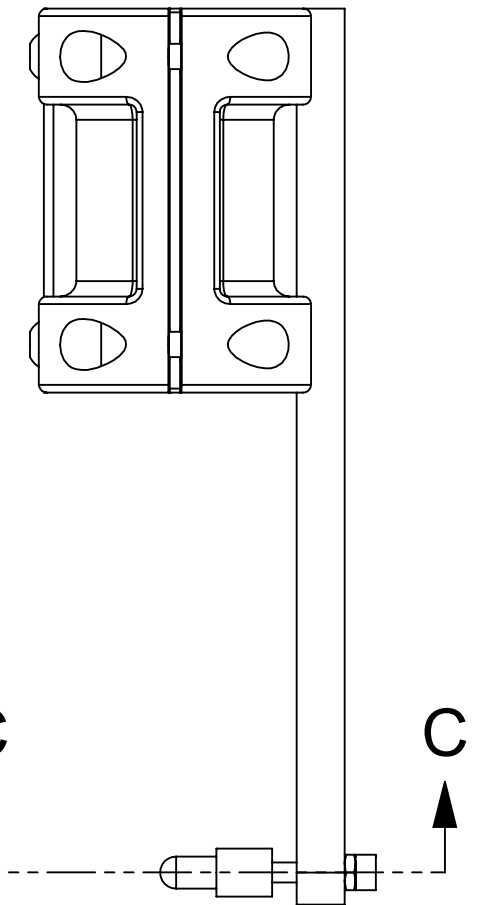

SECTION C-C

NOTES: UNLESS OTHERWISE SPECIFIED.

DO NOT SCALE DRAWING. ALL DIMENSIONS ARE IN MILLIMETERS.

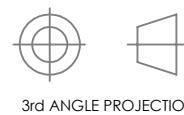

1031 Goodworth Drive, Apex, NC 27539, USA  
Tel: +1.919.772.0115 www.ati-ia.com  
Fax: +1.919.772.8259 ISO 9001 Registered Company

PROPERTY OF ATI INDUSTRIAL AUTOMATION, INC. NOT TO BE REPRODUCED IN ANY MANNER EXCEPT ON ORDER OR WITH PRIOR WRITTEN AUTHORIZATION OF ATI.

DRAWN BY: B. Rose - 6/27/2019

CHECKED BY: D. Bohle - 7/16/2019

TITLE

Profile Follower Customer Drawing, 1.09" Spindle Mount

PROJECT # 180507-1 SHEET 2 OF 2

SCALE  
2:3

SIZE  
B

DRAWING NUMBER  
9630-50-RC-A-PF2

REVISION  
01