

REV.	DESCRIPTION	INITIATOR	DATE
01	INITIAL DRAWING	BRR	6/27/2019

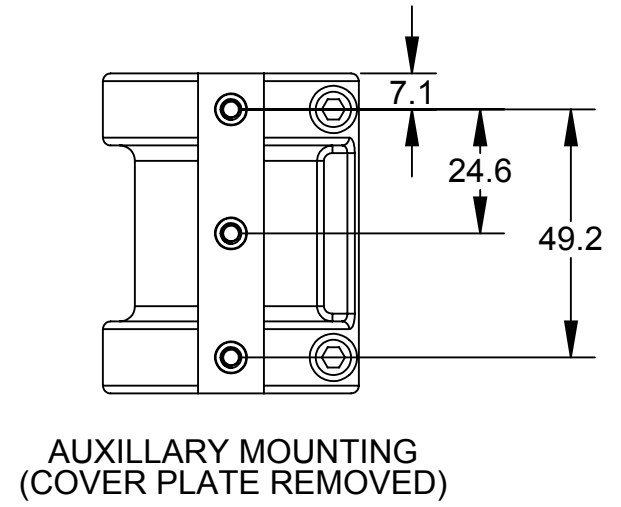
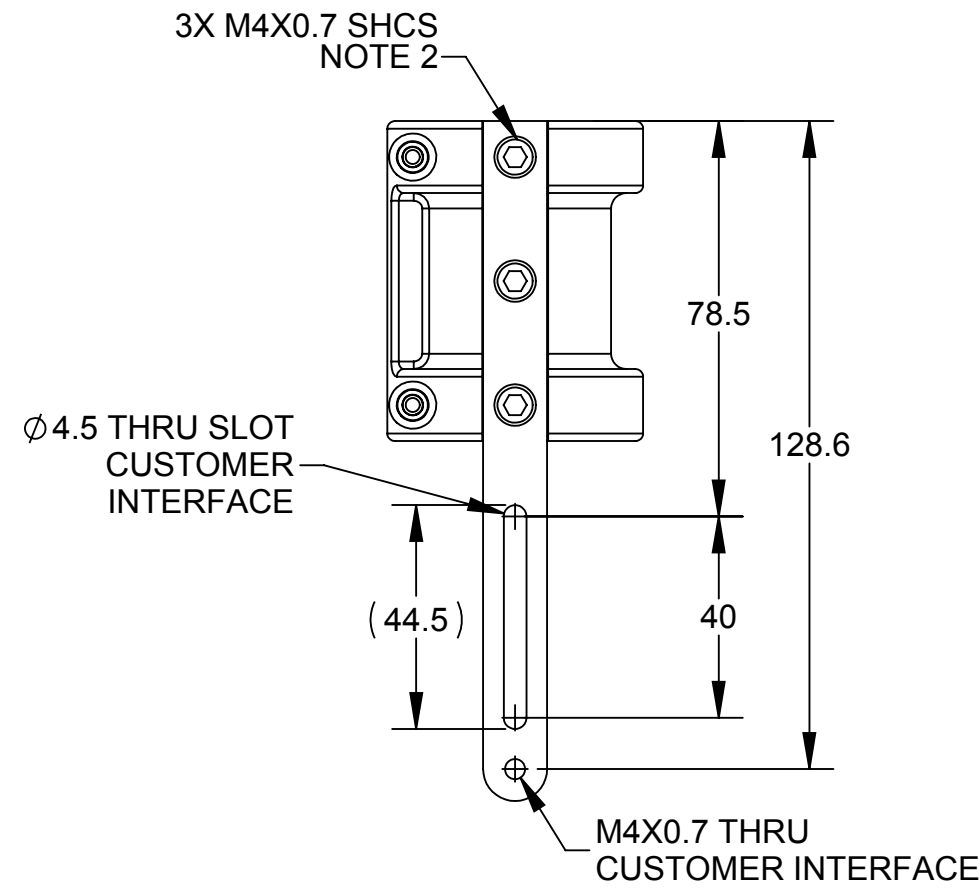
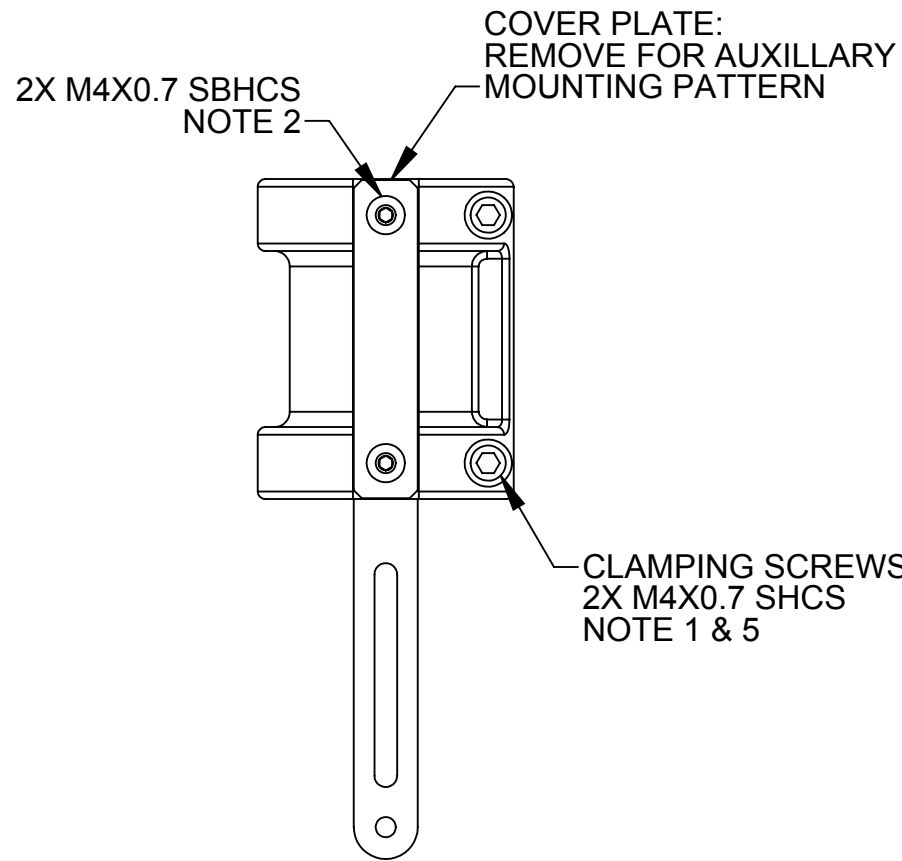
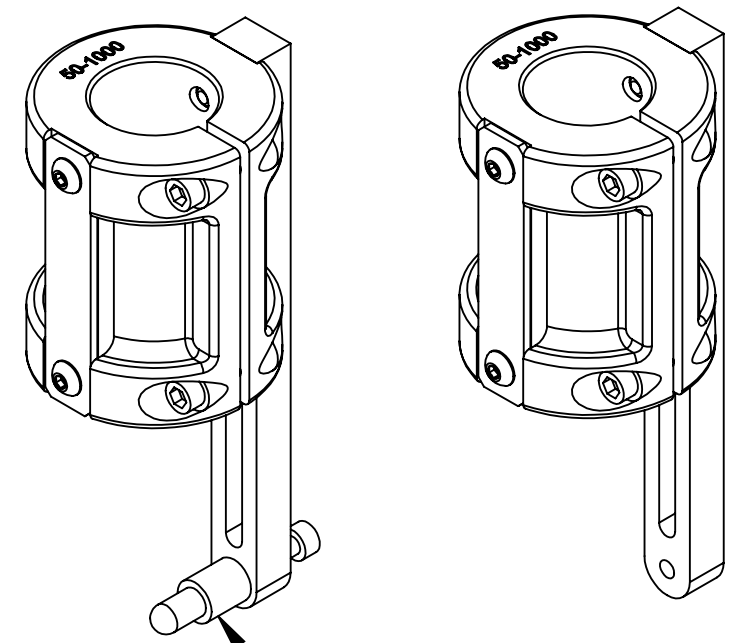
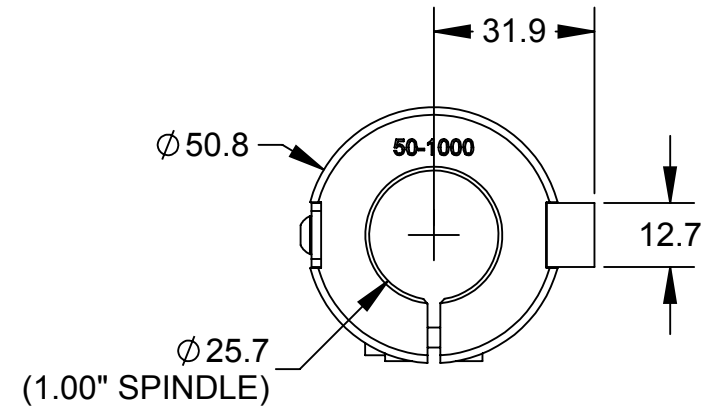

- Notes:
1. CLAMPING SCREWS TO BE TORQUED TO 6IN-LBS WHEN INSTALLING ON TOOL.
 2. IF REMOVED, APPLY LOCTITE 222 OR EQUIVALENT AND TORQUE TO 10IN-LBS.
 3. DUST BELLOWS TO BE REMOVED FOR PROPER CLAMP INSTALLATION.
 4. COMPATIBLE WITH ALL RC-300, RC-340, RS-340, RC-660, AND RS-660 MODELS.
 5. ITEMS SHIP LOOSE WITH UNIT.
 6. APPLY LOCTITE 222 OR EQUIVALENT TO INTERNAL M4 THREADED INSERT.
 7. ALL M4 SHCS HOLDING ALUMINUM ARM TO CLAMP MUST BE PROPERLY INSTALLED THRU BAR AT ALL TIMES.

NOTES: UNLESS OTHERWISE SPECIFIED.

DO NOT SCALE DRAWING. ALL DIMENSIONS ARE IN MILLIMETERS.

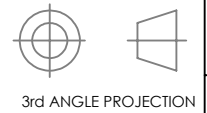

1031 Goodworth Drive, Apex, NC 27539, USA
 Tel: +1.919.772.0115 Email: info@ati-ia.com
 Fax: +1.919.772.8259 www.ati-ia.com
 ISO 9001 Registered Company

PROPERTY OF ATI INDUSTRIAL AUTOMATION, INC. NOT TO BE REPRODUCED IN ANY MANNER EXCEPT ON ORDER OR WITH PRIOR WRITTEN AUTHORIZATION OF ATI.

DRAWN BY: B. Rose - 10/29/2018		TITLE	
CHECKED BY: D. Bohle - 7/16/2019		Profile Follower Customer Drawing, 1" Spinde Mount	
PROJECT # 180507-2	SHEET 1 OF 2	SCALE 2:3	SIZE B
DRAWING NUMBER 9630-50-RC-A-PF1		REVISION 01	

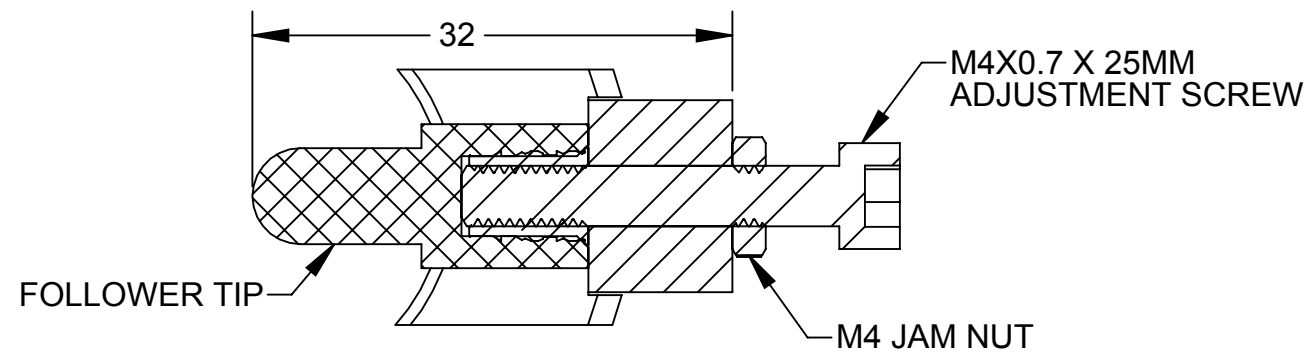
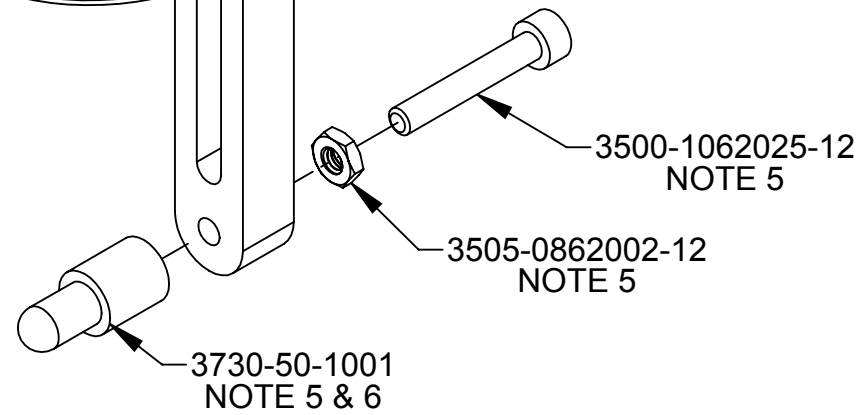
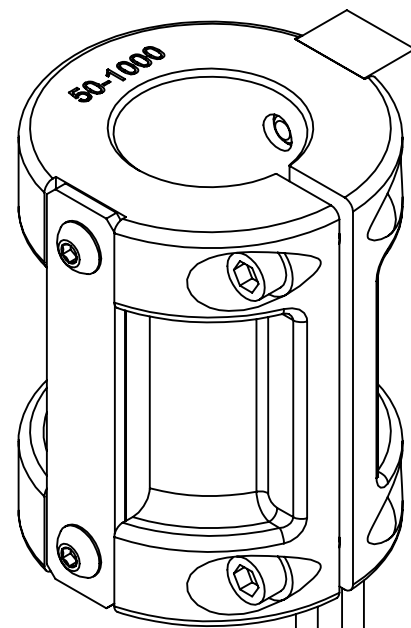

DETAIL B
SCALE 2 : 1

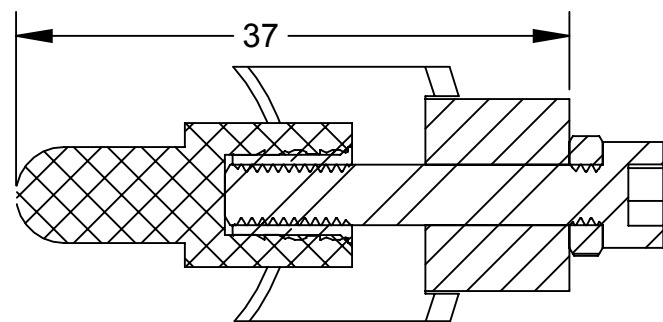

DETAIL D
SCALE 2 : 1
FOLLOWER TIP SHOWN FULLY ADJUSTED

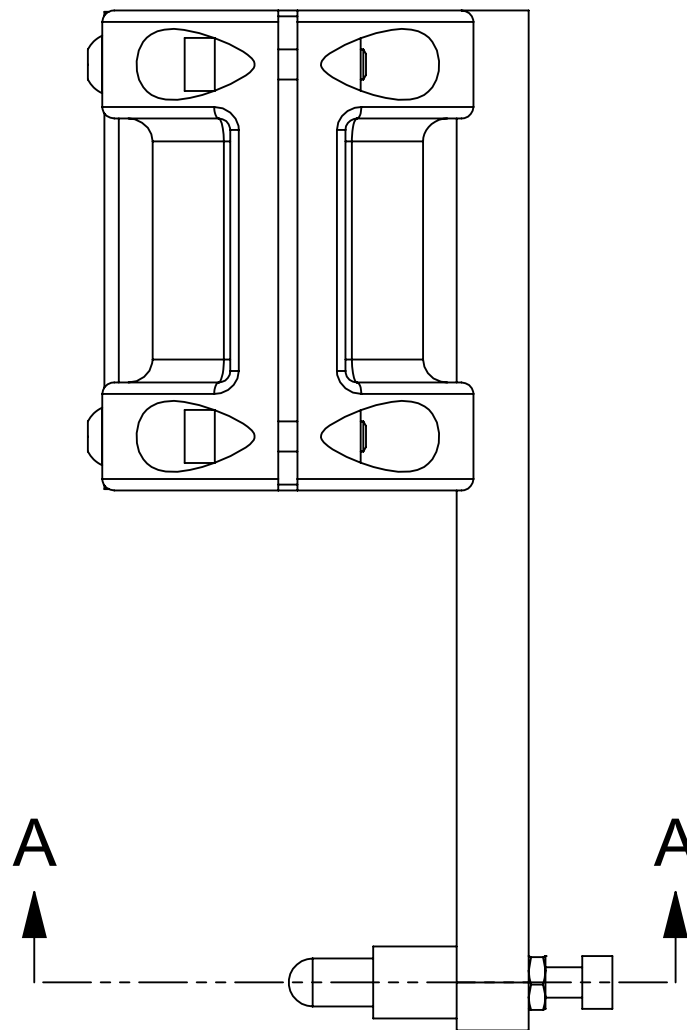

SECTION A-A

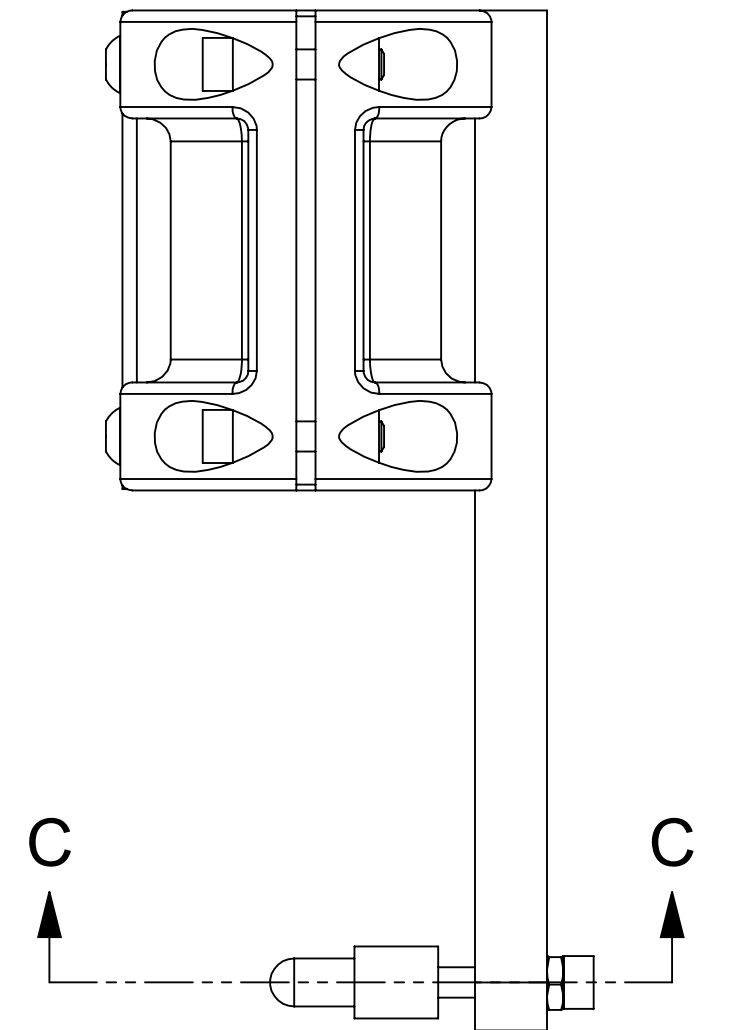

SECTION C-C

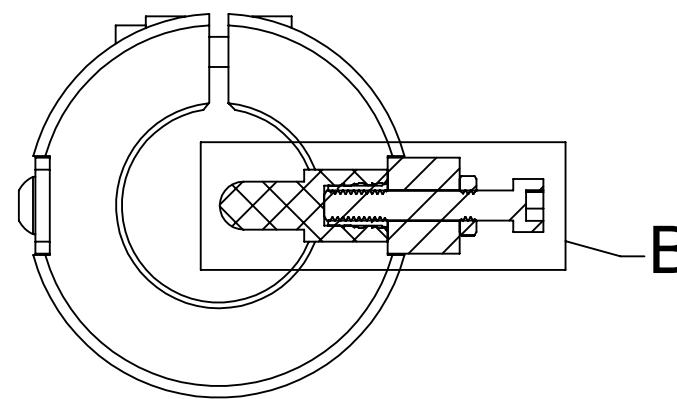

NOTES: UNLESS OTHERWISE SPECIFIED.

DO NOT SCALE DRAWING. ALL DIMENSIONS ARE IN MILLIMETERS.

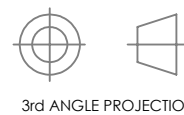

3rd ANGLE PROJECTION



1031 Goodworth Drive, Apex, NC 27539, USA
 Tel: +1.919.772.0115 Email: info@ati-ia.com
 Fax: +1.919.772.8259 www.ati-ia.com
 ISO 9001 Registered Company

PROPERTY OF ATI INDUSTRIAL AUTOMATION, INC. NOT TO BE REPRODUCED IN ANY MANNER EXCEPT ON ORDER OR WITH PRIOR WRITTEN AUTHORIZATION OF ATI.

DRAWN BY: B. Rose - 10/29/2018		TITLE	
CHECKED BY: D. Bohle - 7/16/2019		Profile Follower Customer Drawing, 1" Spinde Mount	
SCALE	SIZE	DRAWING NUMBER	REVISION
1:1	B	9630-50-RC-A-PF1	01
PROJECT # 180507-2 SHEET 2 OF 2			