

REV.	DESCRIPTION	INITIATOR	DATE
02	ECO 18425; Updated Note 7.	MLS	11/2/2019

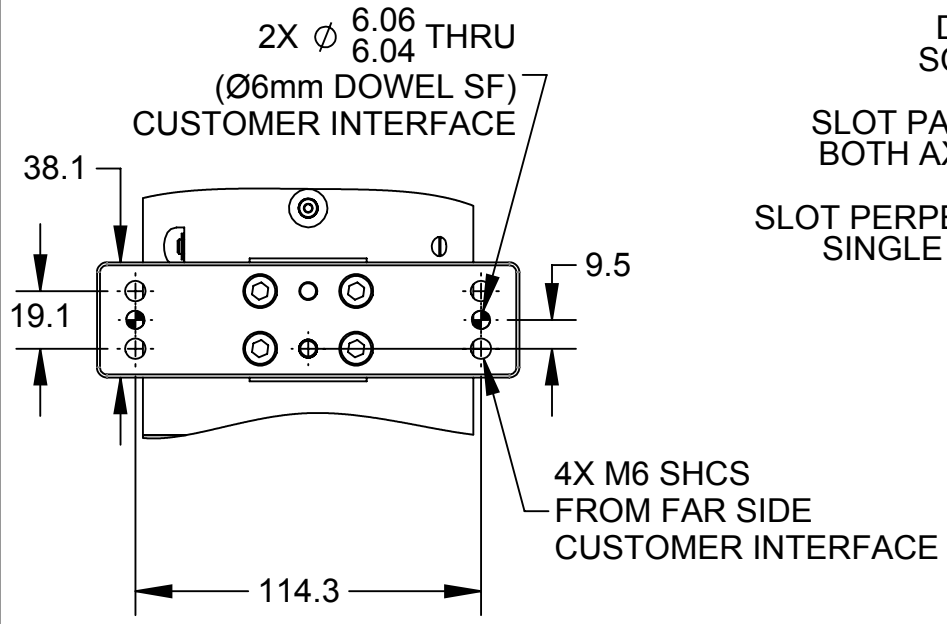

SLOT PARALLEL TO FILE
BOTH AXES UNLOCKED

SLOT PERPENDICULAR TO FILE
SINGLE AXIS LOCKOUT

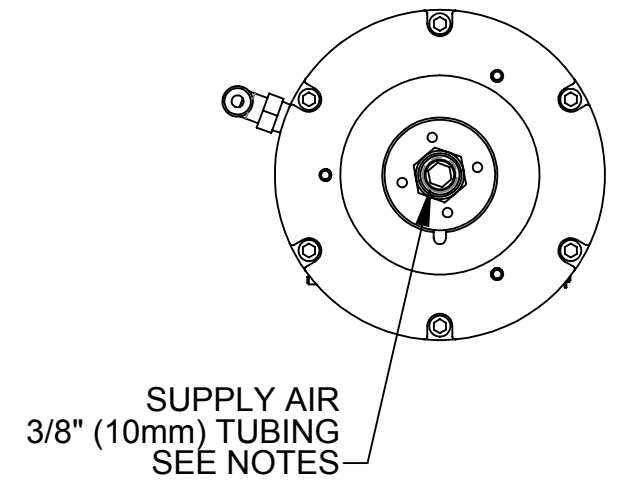
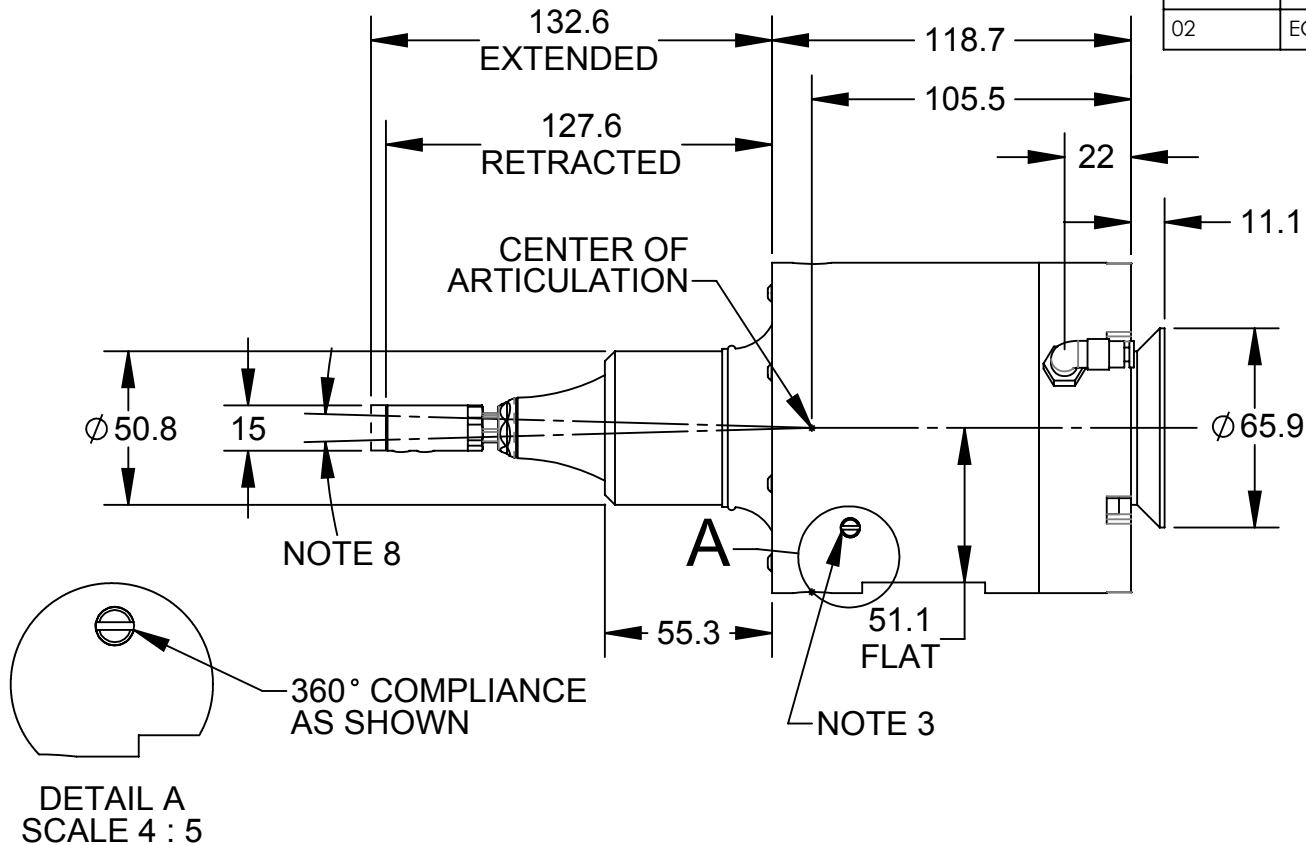
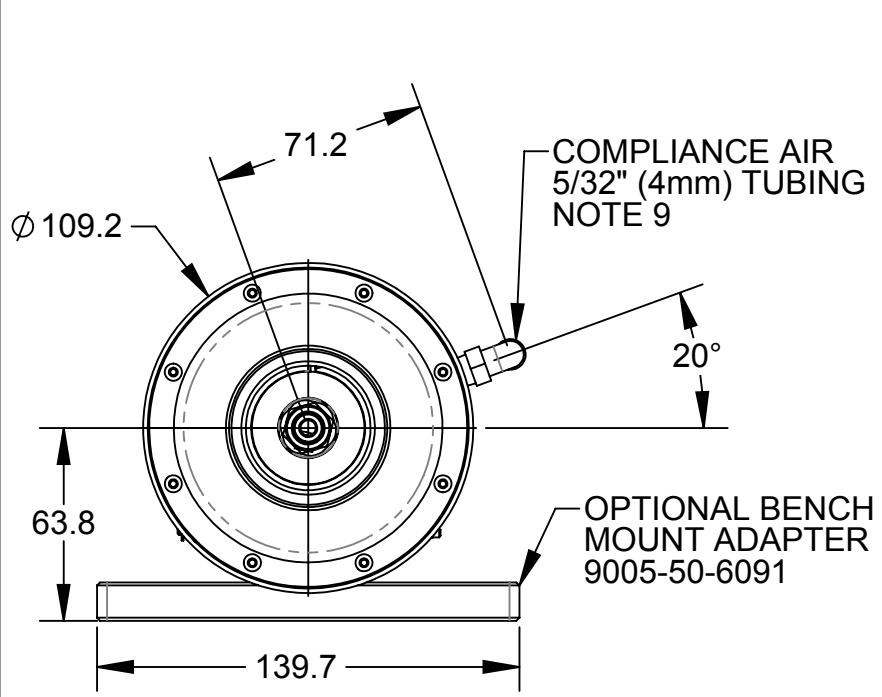
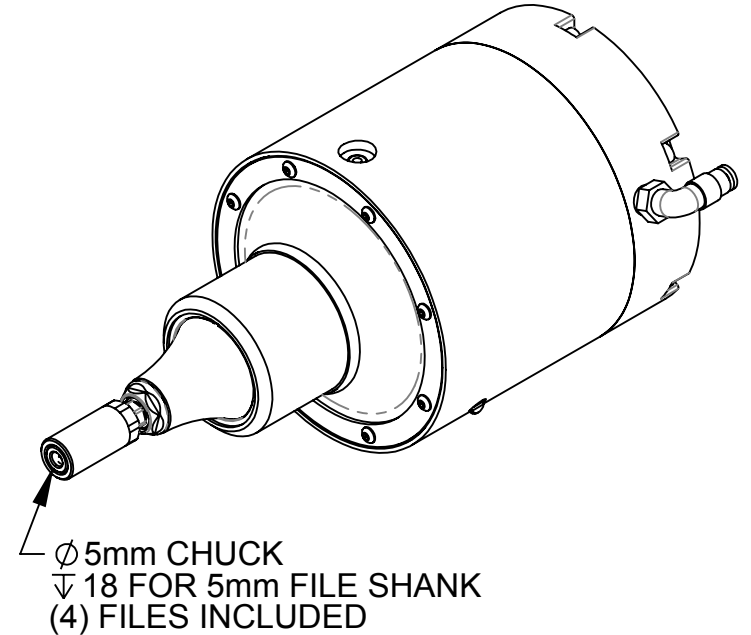
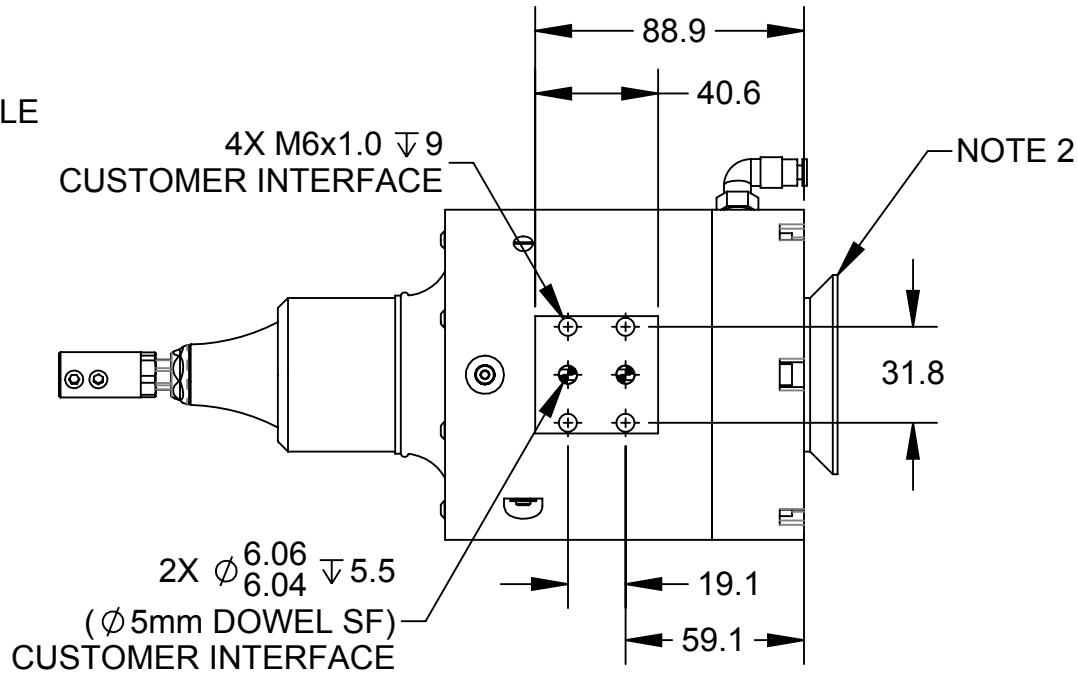

- NOTES:
- AXIAL AIR SUPPLY, 3/8" (10mm) PUSH TO CONNECT
 - OPTIONAL DOVETAIL ATTACHMENT FOR AXIAL MOUNTING.
 - QUARTER TURN SINGLE AXIS LOCK OUT. TURN 90° TO ENGAGE OR DISENGAGE.
 - AIR FILE STROKES PER MINUTE: 12000, NO LOAD.
 - FILER AIR CONSUMPTION: 6 CFM, AT LOAD.
 - FILER AIR QUALITY: 90 PSI, FILTERED 30 MICRON OR BETTER, **LUBRICATION REQUIRED, 1-2 DROPS/MIN.**
 - APPROXIMATE WEIGHT 6.8 LBS (3.08 kg).
 - COMPLIANCE TRAVEL AT COLLET = MAX \pm 1.8° (APPROXIMATELY .32" 8mm).
 - COMPLIANCE AIR SUPPLY PRESSURE 15-60PSI (1-4.1 BAR).

NOTES: UNLESS OTHERWISE SPECIFIED.

DO NOT SCALE DRAWING. ALL DIMENSIONS ARE IN MILLIMETERS.



1031 Goodworth Drive, Apex, NC 27539, USA
Tel: +1.919.772.0115 Email: info@ati-ia.com
Fax: +1.919.772.8259 www.ati-ia.com
ISO 9001 Registered Company

PROPERTY OF ATI INDUSTRIAL AUTOMATION, INC. NOT TO BE REPRODUCED IN ANY MANNER EXCEPT ON ORDER OR WITH PRIOR WRITTEN AUTHORIZATION OF ATI.

DRAWN BY: D. Bohle 4/17/2018		TITLE	
CHECKED BY: BK 3/12/2018		Compliant Reciprocating Tool Customer Drawing, 12k Strokes per Minute, 5mm Stroke	
PROJECT # 170926-3	SHEET 1 OF 2	SCALE 2:5	REVISION 02
SIZE B	DRAWING NUMBER 9630-50-CRT-12-5		

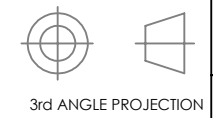

9150-CRT-12-5

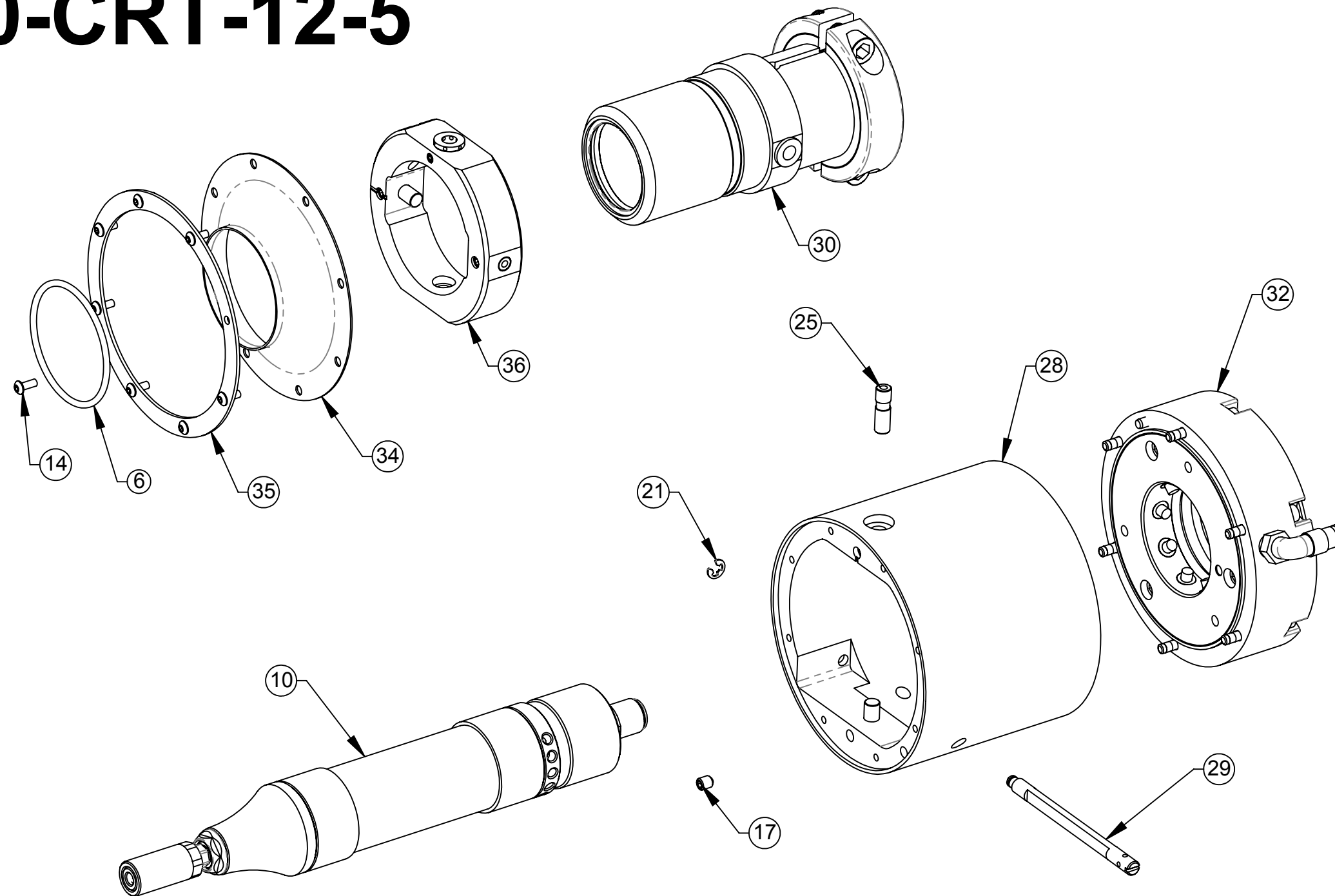

REPLACEMENT FILES	
ATI PART NUMBER	DESCRIPTION
3710-50-1459	FILE, RECTANGULAR, 5MM
3710-50-1460	FILE, ROUND, 5MM
3710-50-1461	FILE, HALF ROUND, 5MM
3710-50-1462	FILE, TRIANGULAR, 5MM

NOTES: UNLESS OTHERWISE SPECIFIED.

DO NOT SCALE DRAWING. ALL DIMENSIONS ARE IN MILLIMETERS.

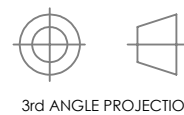

1031 Goodworth Drive, Apex, NC 27539, USA
 Tel: +1.919.772.0115 www.ati-ia.com
 Fax: +1.919.772.8259 ISO 9001 Registered Company

PROPERTY OF ATI INDUSTRIAL AUTOMATION, INC. NOT TO BE REPRODUCED IN ANY MANNER EXCEPT ON ORDER OR WITH PRIOR WRITTEN AUTHORIZATION OF ATI.

DRAWN BY: D. Bohle 4/17/2018

CHECKED BY: BK 3/12/2018

PROJECT # 170926-3 SHEET 2 OF 2

TITLE
Compliant Reciprocating Tool Customer Drawing, 12k Strokes per Minute, 5mm Stroke

SCALE	SIZE	DRAWING NUMBER	REVISION
1:2	B	9630-50-CRT-12-5	02