

Rev.	Description	Initiator	Date
02	ECO 20593: UPDATED TO REFLECT ADDED HOLES IN PLATE. UPDATED LENGTHS OF MATING PIN ASSY (57.4 WAS 56 AND 45.2 WAS 46).	REH/SZJ	1/14/2022

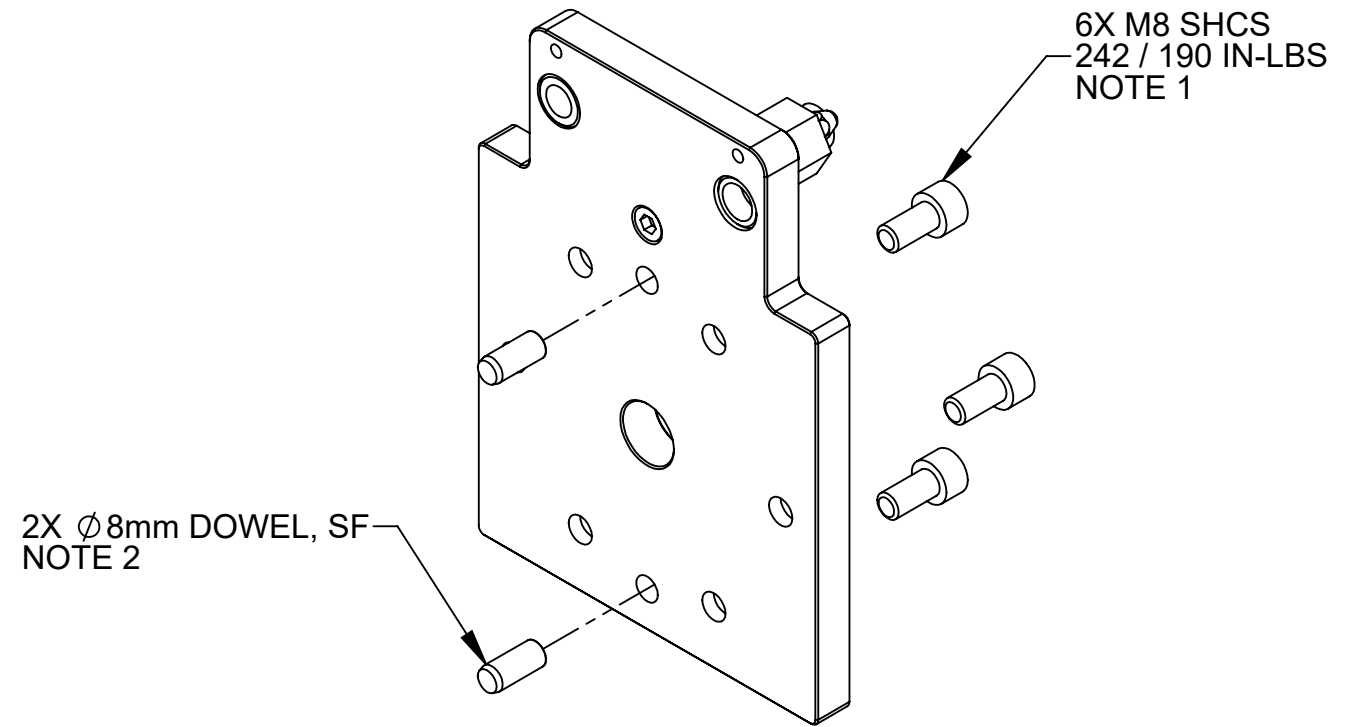
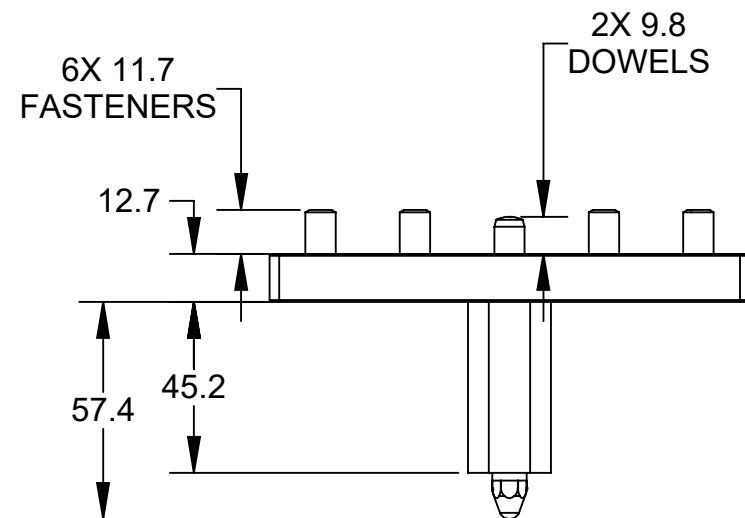
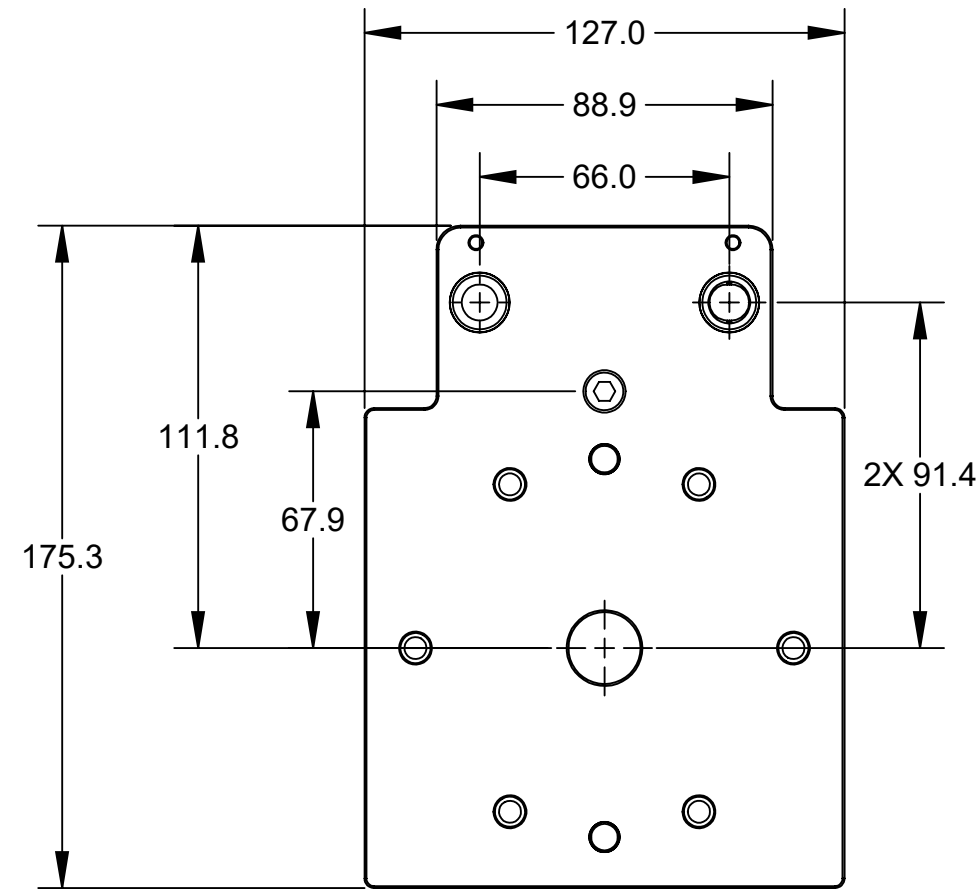

- Notes:
1. FASTENERS SHIPPED LOOSE. CUSTOMER TO USE LOCTITE OR SIMILAR THREAD LOCKER AND TORQUE TO LISTED VALUE.
 2. DOWELS SHIPPED LOOSE. CUSTOMER TO PRESS DOWEL INTO ATI TOOL CHANGER.

ITEM NO.	QTY	PART NUMBER	DESCRIPTION
1	1	9120-TSS-HBQ-9957	TSS Tooling Interface Plate for QC-46 - Blank
NOTES: UNLESS OTHERWISE SPECIFIED.		<p>1031 Goodworth Drive, Apex, NC 27539, USA Tel: +1.919.772.0115 Fax: +1.919.772.8259 www.ati-ia.com ISO 9001 Registered Company</p>	
DO NOT SCALE DRAWING. ALL DIMENSIONS ARE IN MILLIMETERS.		<p>PROPERTY OF ATI INDUSTRIAL AUTOMATION, INC. NOT TO BE REPRODUCED IN ANY MANNER EXCEPT ON ORDER OR WITH PRIOR WRITTEN AUTHORIZATION OF ATI.</p>	
<p>DRAWN BY: T. Burns 12/28/16 CHECKED BY: B. Kendrick 12/28/16</p>		<p>TITLE TSS Tooling Interface Plate for QC-46</p>	
<p>PROJECT # 160517-1 SHEET 1 OF 1</p>		SCALE	REVISION
<p>3rd ANGLE PROJECTION</p>		1:2	02
		SIZE	DRAWING NUMBER
		B	9630-20-TSS-HBQ-9957