

Rev.	Description	Initiator	Date
01	Initial Drawing	JMW	02/26/2014

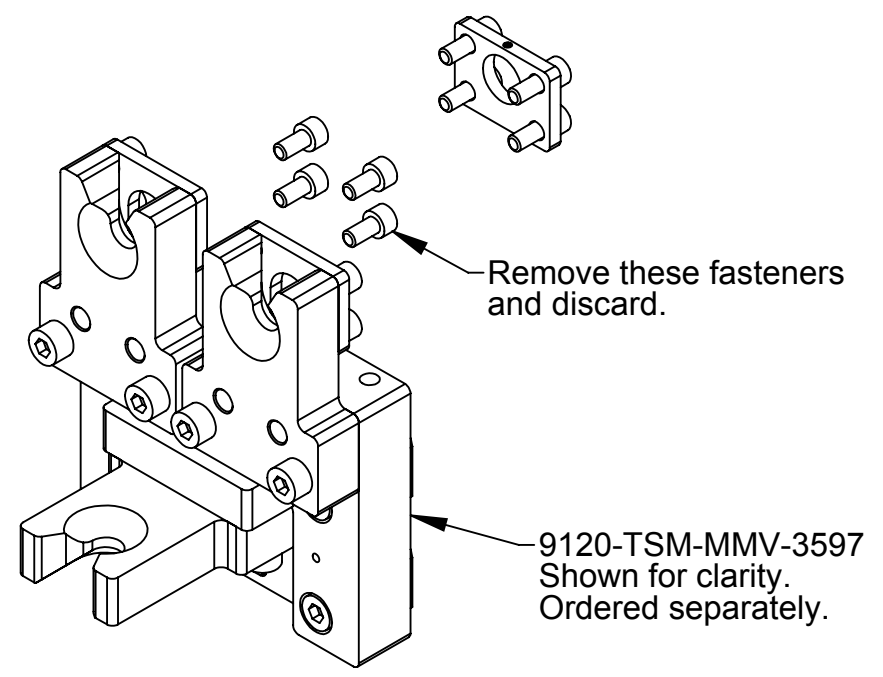
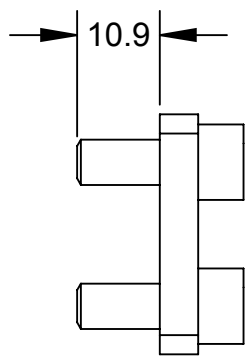
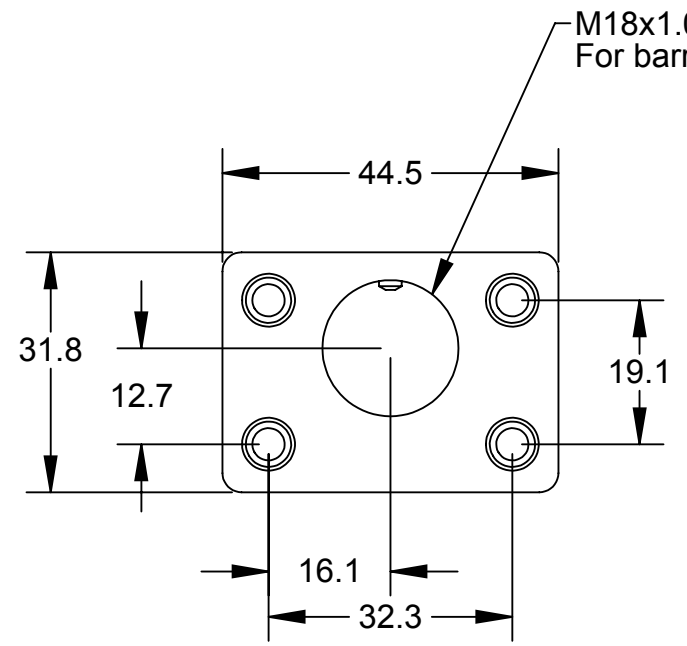
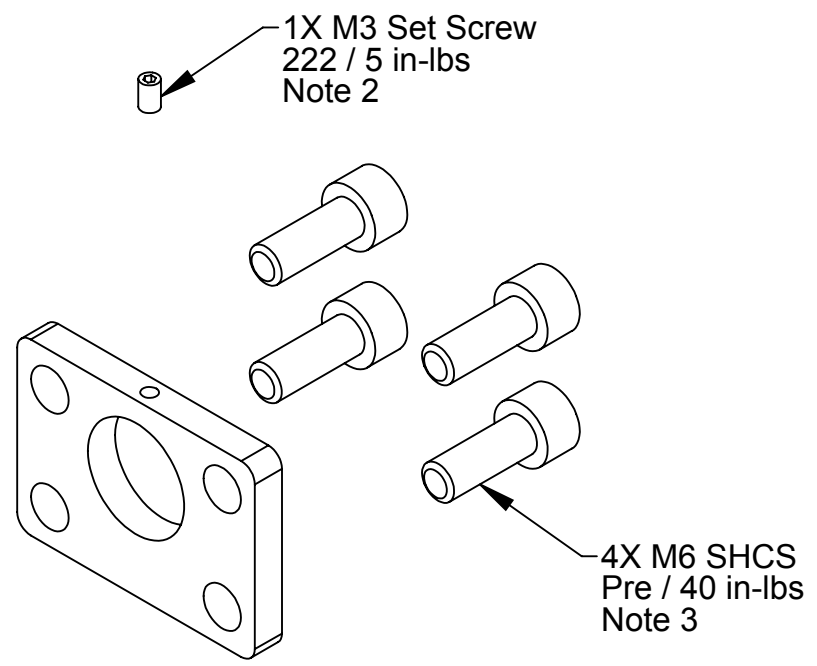
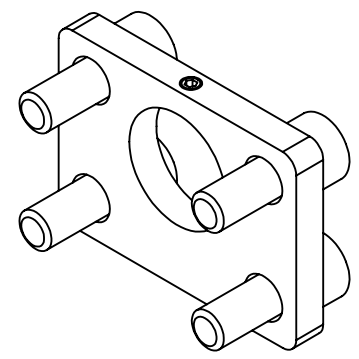
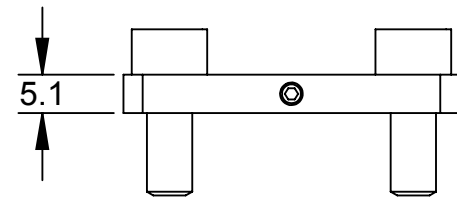

- Notes:
1. Fasteners shipped loose.
 2. Customer to use Loctite or similar threadlocker and torque to listed torque value.
 3. Customer to torque pre-applied fasteners to listed torque value.

ITEM NO.	QTY.	PART NUMBER	DESCRIPTION
1	1	9120-TSM-SM-4206	TSM Sensor Holder

NOTES: UNLESS OTHERWISE SPECIFIED.
DO NOT SCALE DRAWING. ALL DIMENSIONS ARE IN MILLIMETERS.



1031 Goodworth Drive, Apex, NC 27539, USA
Tel: +1.919.772.0115 Email: info@ati-ia.com
Fax: +1.919.772.8259 www.ati-ia.com
ISO 9001 Registered Company

PROPERTY OF ATI INDUSTRIAL AUTOMATION, INC. NOT TO BE REPRODUCED IN ANY MANNER EXCEPT ON ORDER OR WITH PRIOR WRITTEN AUTHORIZATION OF ATI.

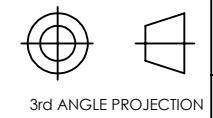

DRAWN BY: J. Winterroth, 2/25/14		TITLE	
CHECKED BY: D. Norton, 2/27/14		TSM Sensor Holder	
PROJECT # -	SHEET 1 OF 1	SCALE	SIZE
		1:1	B
		DRAWING NUMBER	REVISION
		9630-20-TSM-SM-4206	01