

Rev.	Description	Initiator	Date
01	Initial Drawing	JMW	11/25/2013

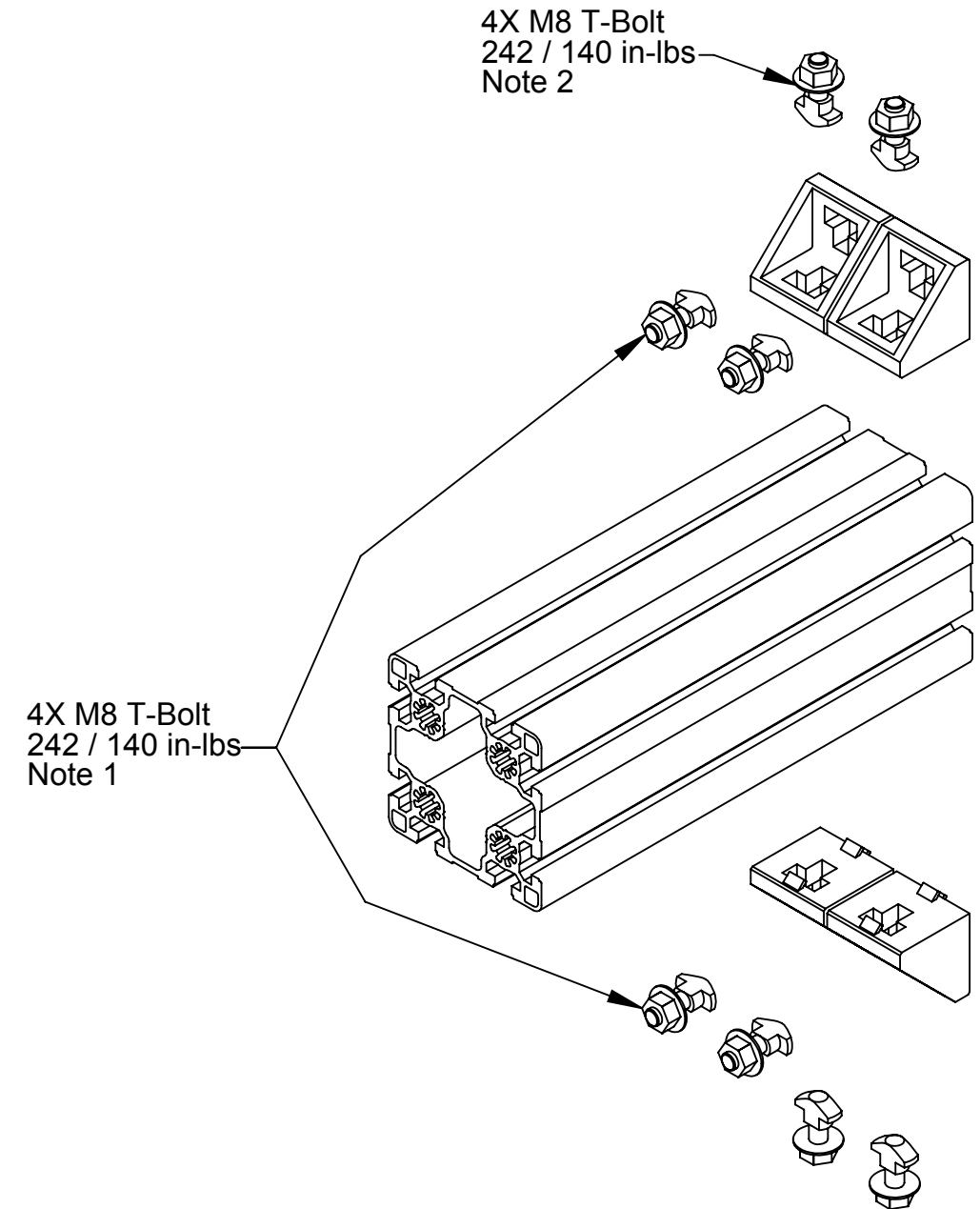
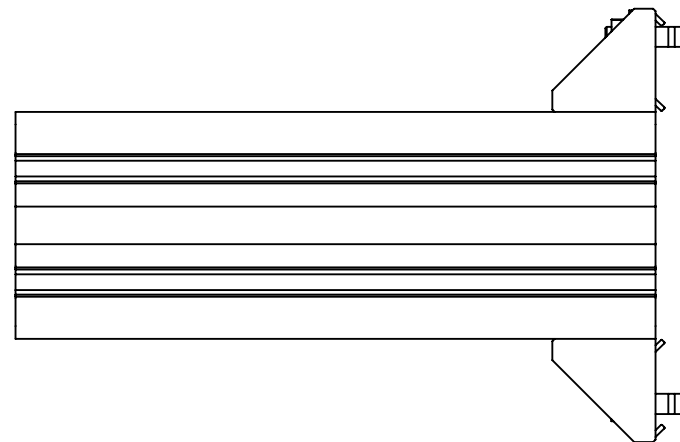
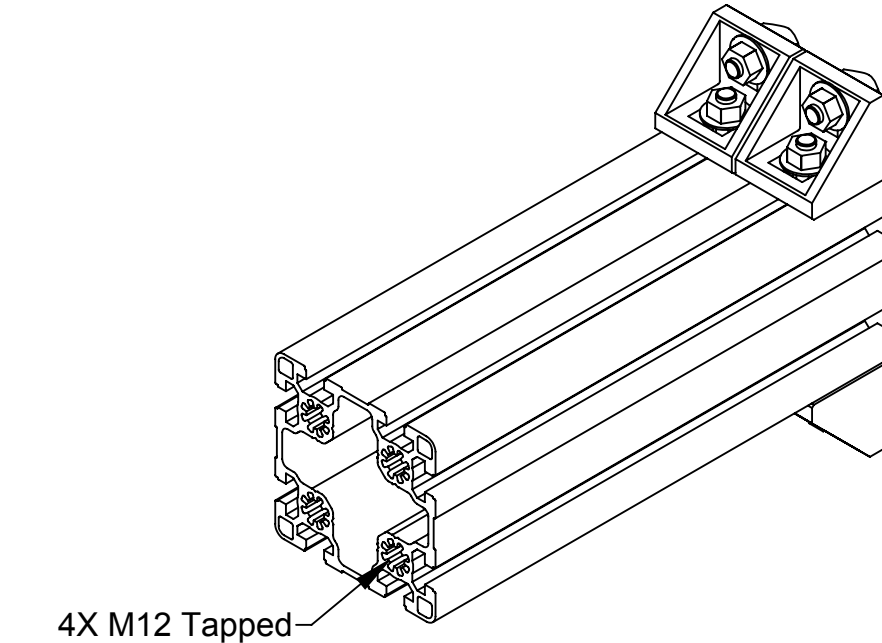
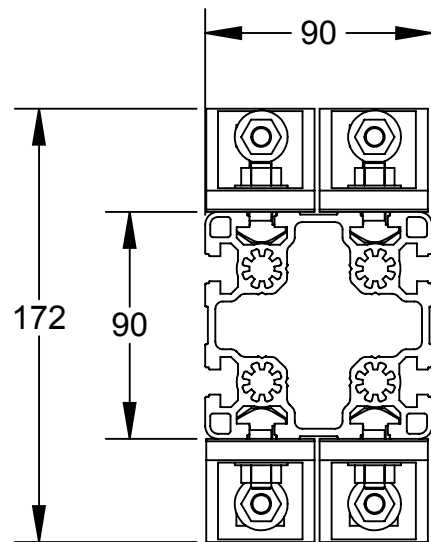
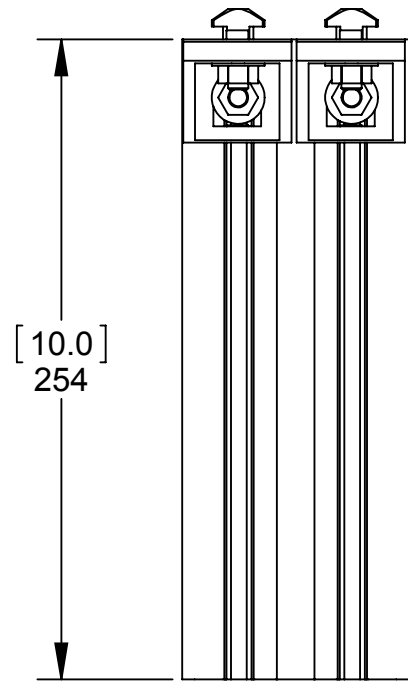

Notes:

1. Supplied hand tight w/o threadlocker. Customer to use Loctite or similar threadlocker and torque fasteners to listed torque value.
2. Customer to use Loctite or similar threadlocker and torque fasteners to listed torque value.

NOTES: UNLESS OTHERWISE SPECIFIED.

DO NOT SCALE DRAWING. ALL DIMENSIONS ARE IN MILLIMETERS.



3rd ANGLE PROJECTION

ITEM NO.	QTY.	PART NUMBER	DESCRIPTION
1	1	9120-TSM-HE-3321	TSM Horizontal Extension 10"

ATI INDUSTRIAL AUTOMATION

1031 Goodworth Drive, Apex, NC 27539, USA
Tel: +1.919.772.0115 Email: info@ati-ia.com
Fax: +1.919.772.8259 www.ati-ia.com
ISO 9001 Registered Company

PROPERTY OF ATI INDUSTRIAL AUTOMATION, INC. NOT TO BE REPRODUCED IN ANY MANNER EXCEPT ON ORDER OR WITH PRIOR WRITTEN AUTHORIZATION OF ATI.

TSM Horizontal Extension, 10"

DRAWN BY: J. Winterroth, 11/25/13	CHECKED BY: D. Norton, 12/04/13	SCALE: 1:3	SIZE: B	DRAWING NUMBER: 9630-20-TSM-HE-3321	REVISION: 01
-----------------------------------	---------------------------------	------------	---------	-------------------------------------	--------------