

Rev.	Description	Initiator	Date
01	Initial Drawing	JMW	02/14/2014
02	Eco 14741; Changed M5 CB to M6 CB	DS	8/4/2016

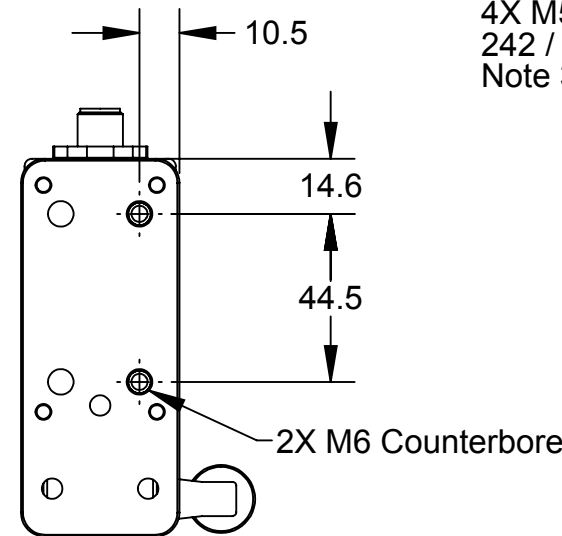

4X M5 SHCS  
242 / 50 in-lbs  
Note 3

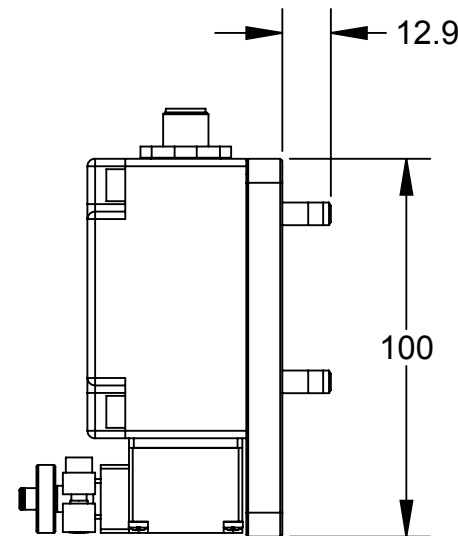
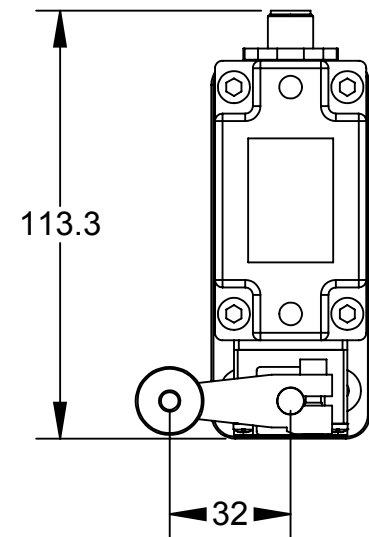
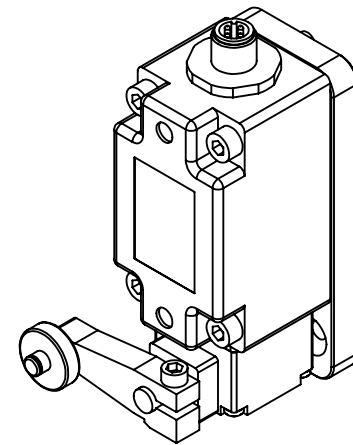
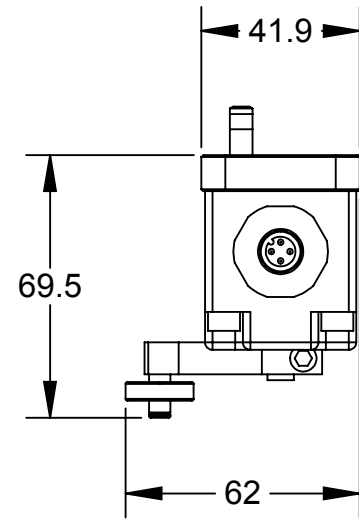
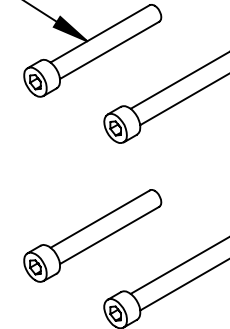

2X M6 SHCS  
Pre / 50 in-lbs  
Note 2

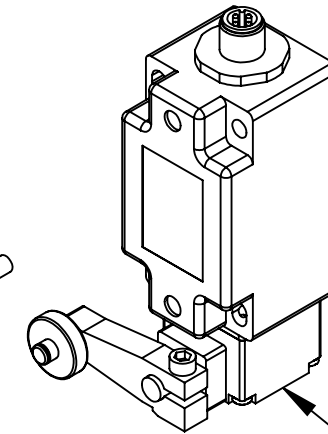
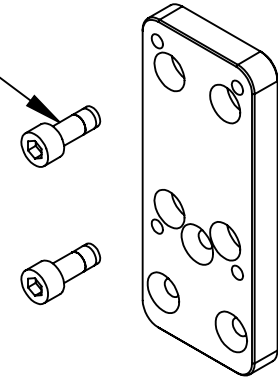

Safety Switch and Connector  
4-pin M12 Eurofast  
9005-20-1165  
Note 1, 4

Notes:

1. Fasteners and switch shipped loose. To be installed by customer.
2. Customer to install pre-applied fasteners and torque to listed torque value.
3. Customer to use Loctite or similar thread locker and torque to listed torque value.
4. Customer to orient switch arm as needed.

ITEM NO.	QTY.	PART NUMBER	DESCRIPTION
1	1	9120-TSL-SS-6044	TSL Tool Stand Interlock Switch Assembly no Trip Dog
NOTES: UNLESS OTHERWISE SPECIFIED.		 <p>1031 Goodworth Drive, Apex, NC 27539, USA Tel: +1.919.772.0115 Email: info@ati-ia.com Fax: +1.919.772.8259 www.ati-ia.com ISO 9001 Registered Company</p> <p>PROPERTY OF ATI INDUSTRIAL AUTOMATION, INC. NOT TO BE REPRODUCED IN ANY MANNER EXCEPT ON ORDER OR WITH PRIOR WRITTEN AUTHORIZATION OF ATI.</p>	
DO NOT SCALE DRAWING. ALL DIMENSIONS ARE IN MILLIMETERS.			
DRAWN BY: J. Winterroth, 2/14/14		TITLE	
CHECKED BY: D. Norton, 2/18/14		TSL Tool Stand Interlock Switch Assembly no Trip Dog	
PROJECT # -		SCALE	REVISION
SHEET 1 OF 2		1:2	02
		SIZE	DRAWING NUMBER
		B	9630-20-TSL-SS-6044

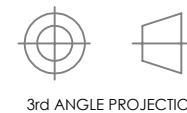

Rev.	Description	Initiator	Date
-	See Sheet1	-	-

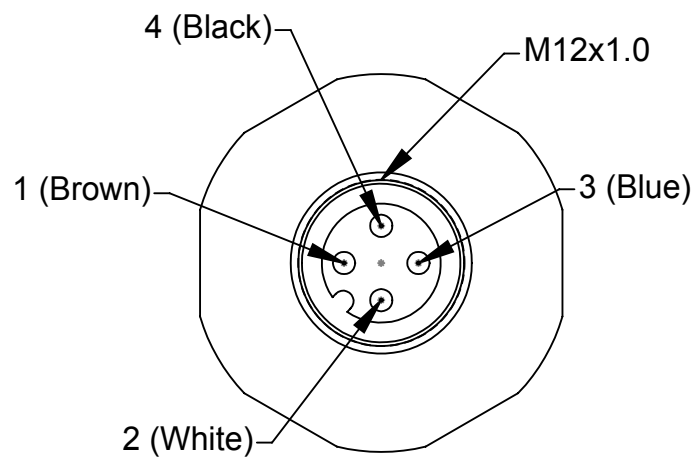
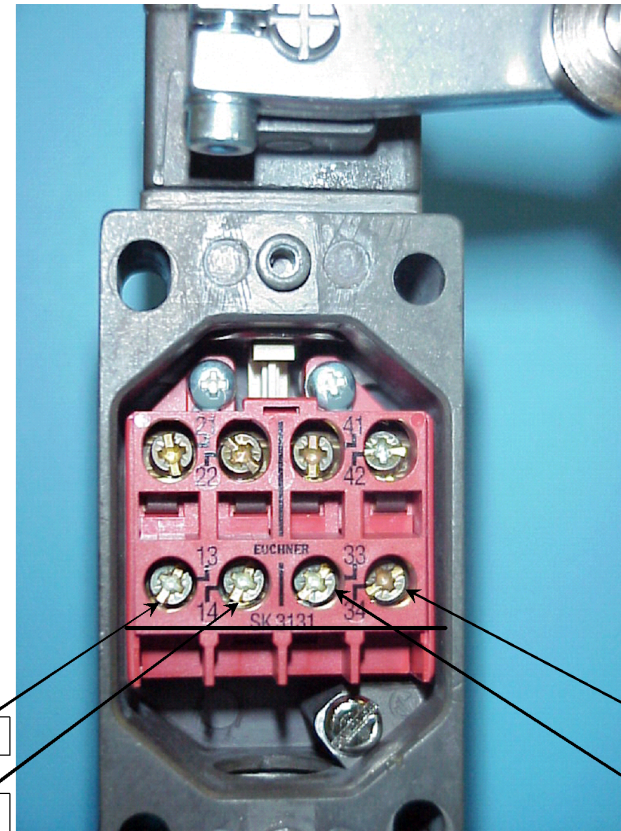

Face View  
Part #1510-1313006-04  
4-Pin Male Eurofast Receptacle

Pin #:	Wire Color	Contact Type (Group)	Internal switch #:
Pin 1	Brown	N.O. (Pin 1 & 4)	13
Pin 2	White	N.O. (Pin 2 & 3)	33
Pin 3	Blue	N.O. (Pin 2 & 3)	34
Pin 4	Black	N.O. (Pin 1 & 4)	14

Wiring Diagram (switch not actuated)

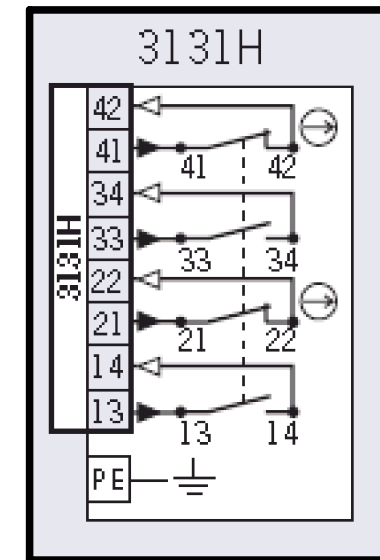

NOTES: UNLESS OTHERWISE SPECIFIED.

DO NOT SCALE DRAWING. ALL DIMENSIONS ARE IN MILLIMETERS.



3rd ANGLE PROJECTION



1031 Goodworth Drive, Apex, NC 27539, USA  
Tel: +1.919.772.0115 Email: info@ati-ia.com  
Fax: +1.919.772.8259 www.ati-ia.com  
ISO 9001 Registered Company

PROPERTY OF ATI INDUSTRIAL AUTOMATION, INC. NOT TO BE REPRODUCED IN ANY MANNER EXCEPT ON ORDER OR WITH PRIOR WRITTEN AUTHORIZATION OF ATI.

DRAWN BY: J. Winterroth, 2/14/14		TITLE	
CHECKED BY: D. Norton, 2/18/14		TSL Tool Stand Interlock Switch Assembly no Trip Dog	
PROJECT # -	SHEET 2 OF 2	SCALE 1:2	SIZE B
DRAWING NUMBER 9630-20-TSL-SS-6044		REVISION 02	