

Rev.	Description	Initiator	Date
02	ECO 14221; Replace 3700-20-8089 with 3700-20-9475	SZJ	3/30/2016

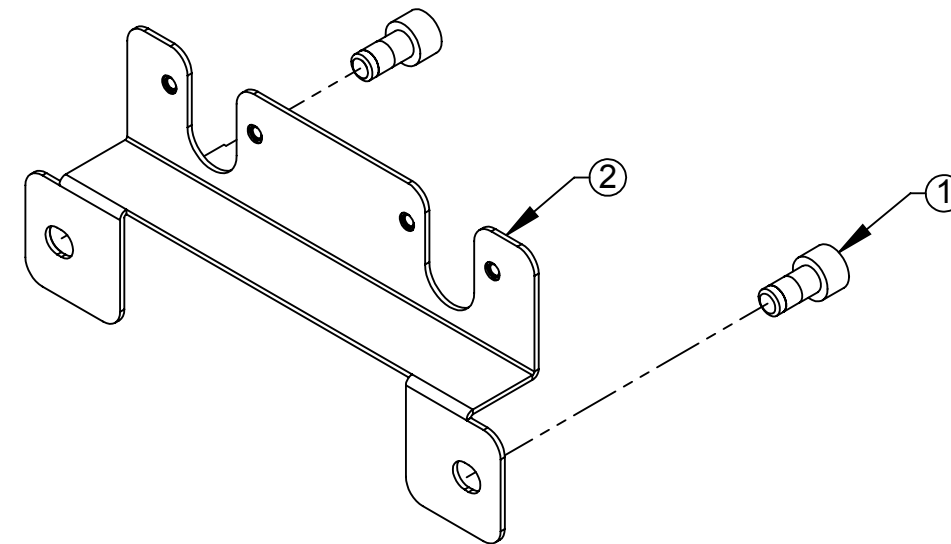
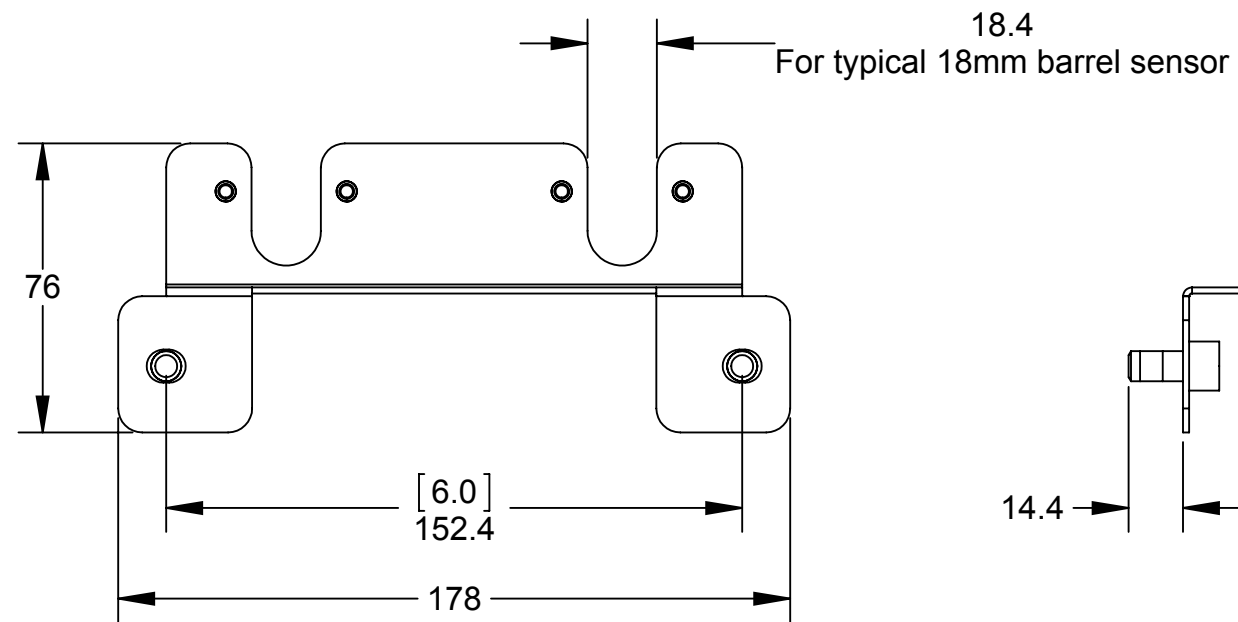

ITEM NO.	QTY.	PART NUMBER	DESCRIPTION
1	2	3500-1068016-15A	M8 x 16mm SHCS, Blue Dyed Magni-565 w/ ND Microspheres Epoxy
2	1	3700-20-9475	TSL SMA Bracket, SS, PEM Inserts

NOTES: UNLESS OTHERWISE SPECIFIED.

DO NOT SCALE DRAWING. ALL DIMENSIONS ARE IN MILLIMETERS.



1031 Goodworth Drive, Apex, NC 27539, USA
 Tel: +1.919.772.0115 Email: info@ati-ia.com
 Fax: +1.919.772.8259 www.ati-ia.com
 ISO 9001 Registered Company

PROPERTY OF ATI INDUSTRIAL AUTOMATION, INC. NOT TO BE REPRODUCED IN ANY MANNER EXCEPT ON ORDER OR WITH PRIOR WRITTEN AUTHORIZATION OF ATI.

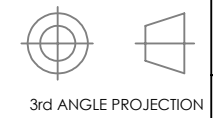

DRAWN BY: J. Winterroth, 7/29/13

CHECKED BY: D. Norton, 7/29/13

PROJECT # 130417-6 SHEET 1 OF 1

TITLE		SCALE	SIZE	DRAWING NUMBER	REVISION
TSL Dual Sensor Module Drawing		1:2	B	9630-20-TSL-SMA-8089	02