

Rev.	Description	Initiator	Date
01	Initial Drawing	JMW	10/22/2013

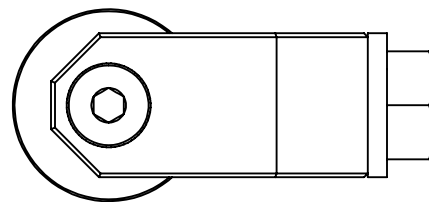
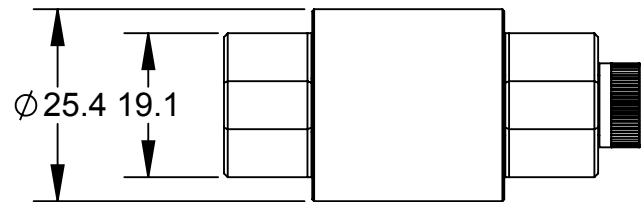
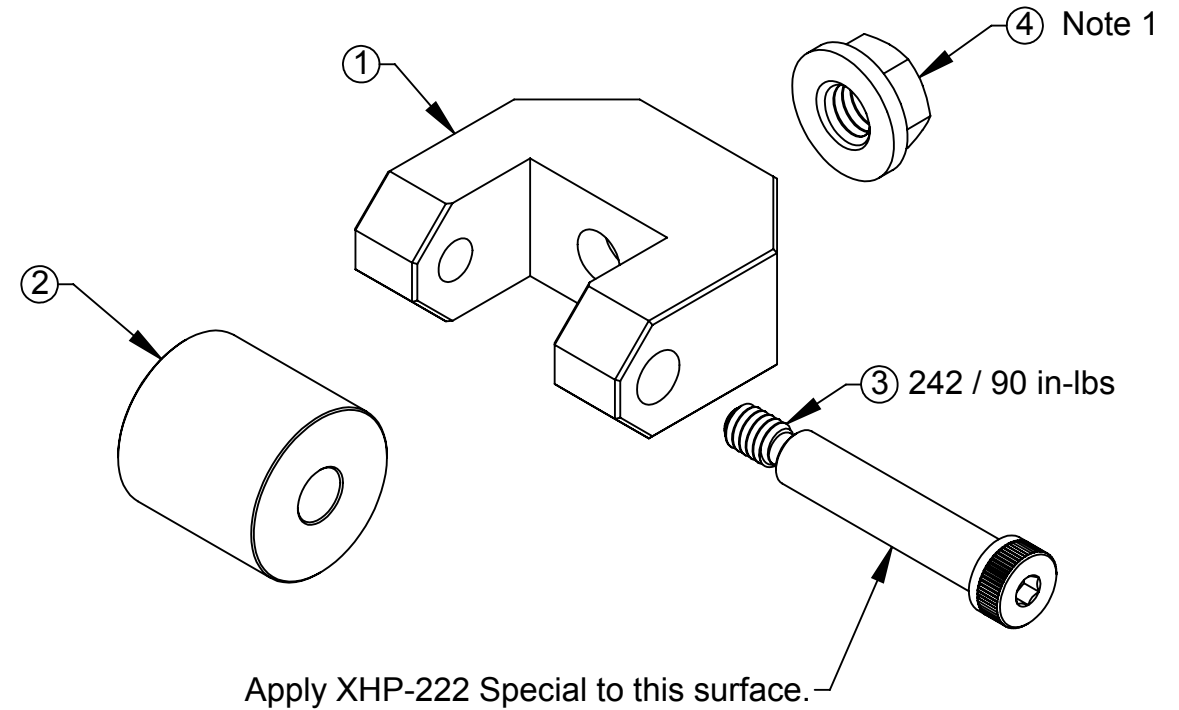
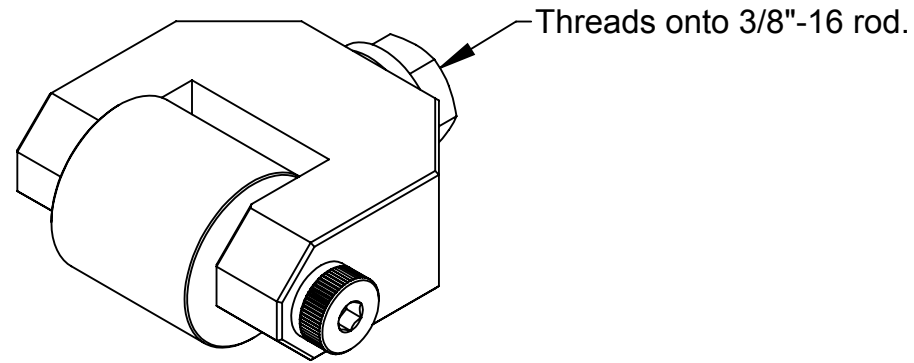
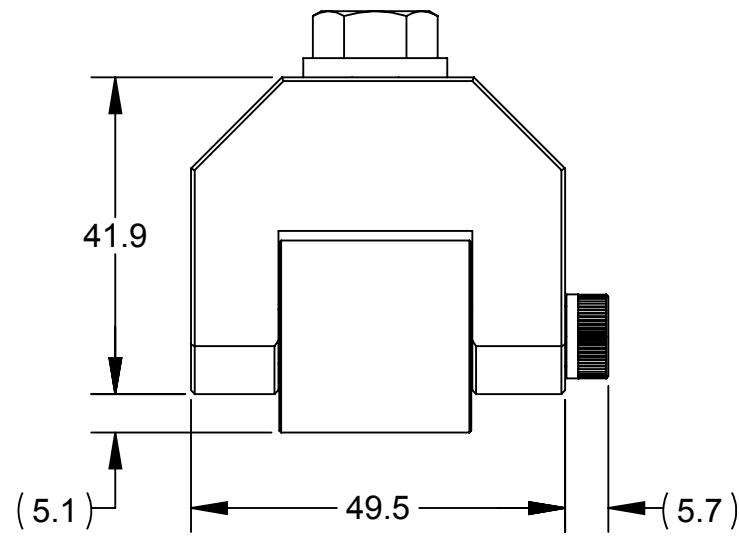

9120-TSL-PS-8229 - Detail

ITEM NO.	QTY.	PART NUMBER	DESCRIPTION
1	1	3700-20-8229	TSL Roller Stop Bracket
2	1	3710-20-3430	UHMW Roller - 1" OD, 5/16" ID, 1" Wide
3	1	3500-2024150-11	Shoulder SHCS, 1/4"-20 Thread, 5/16" Shoulder, 1.5" Long Alloy Steel
4	1	3505-0859000-12	3/8" Flange Hex Locknut, Zinc Plated

NOTES: UNLESS OTHERWISE SPECIFIED.

DO NOT SCALE DRAWING. ALL DIMENSIONS ARE IN MILLIMETERS.



1031 Goodworth Drive, Apex, NC 27539, USA
 Tel: +1.919.772.0115 Email: info@ati-ia.com
 Fax: +1.919.772.8259 www.ati-ia.com
 ISO 9001 Registered Company

PROPERTY OF ATI INDUSTRIAL AUTOMATION, INC. NOT TO BE REPRODUCED IN ANY MANNER EXCEPT ON ORDER OR WITH PRIOR WRITTEN AUTHORIZATION OF ATI.

Notes:

- 1. Hex nut shipped loose.



3rd ANGLE PROJECTION

DRAWN BY: J. Winterroth, 10/22/13		TITLE	
CHECKED BY: D. Norton, 10/23/13		TSL Post Support - Roller	
PROJECT # 121218-4	SHEET 1 OF 1	SCALE 1:1	SIZE B
DRAWING NUMBER 9630-20-TSL-PS-8229		REVISION 01	