

| Rev. | Description | Initiator | Date |
|------|---|-----------|-----------|
| 02 | ECO 18027; Removed note and updated callout to "Pre". | MLS | 9/23/2019 |

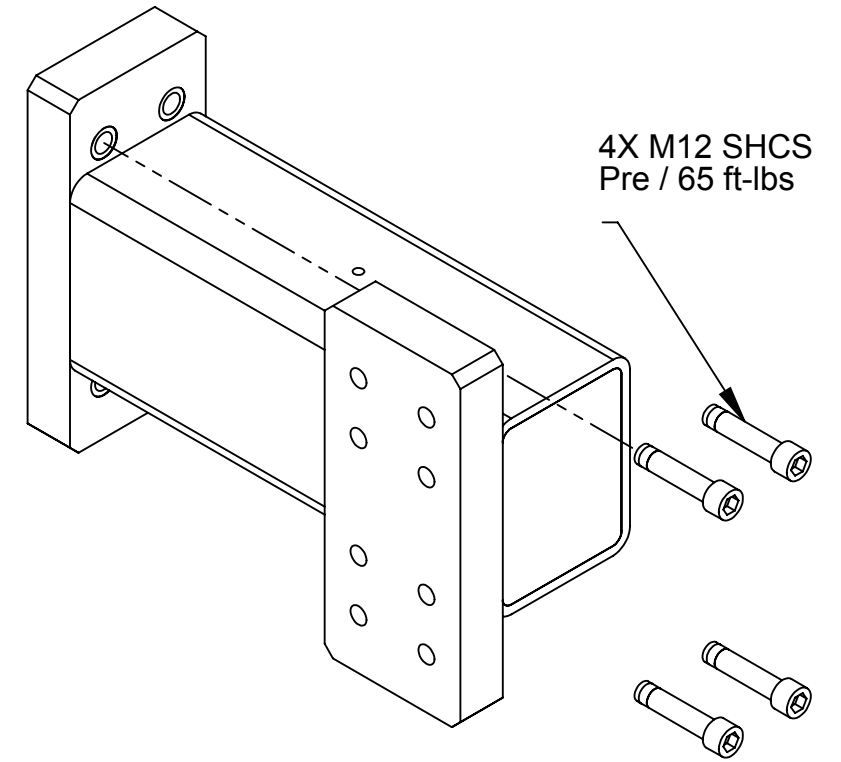

| ITEM NO. | QTY. | PART NUMBER | DESCRIPTION |
|----------|------|---------------------|------------------------------------|
| 1 | 1 | 9120-TSL-HE12A-7572 | TSL Horizontal Extension, 12", 90° |

NOTES: UNLESS OTHERWISE SPECIFIED.
 DO NOT SCALE DRAWING. ALL DIMENSIONS ARE IN MILLIMETERS.

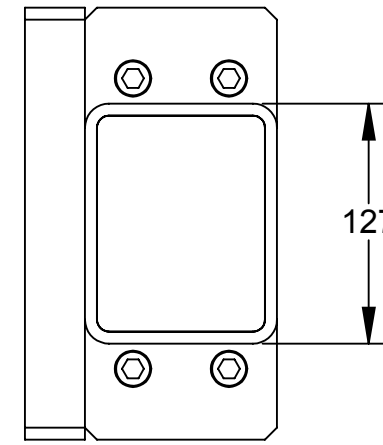
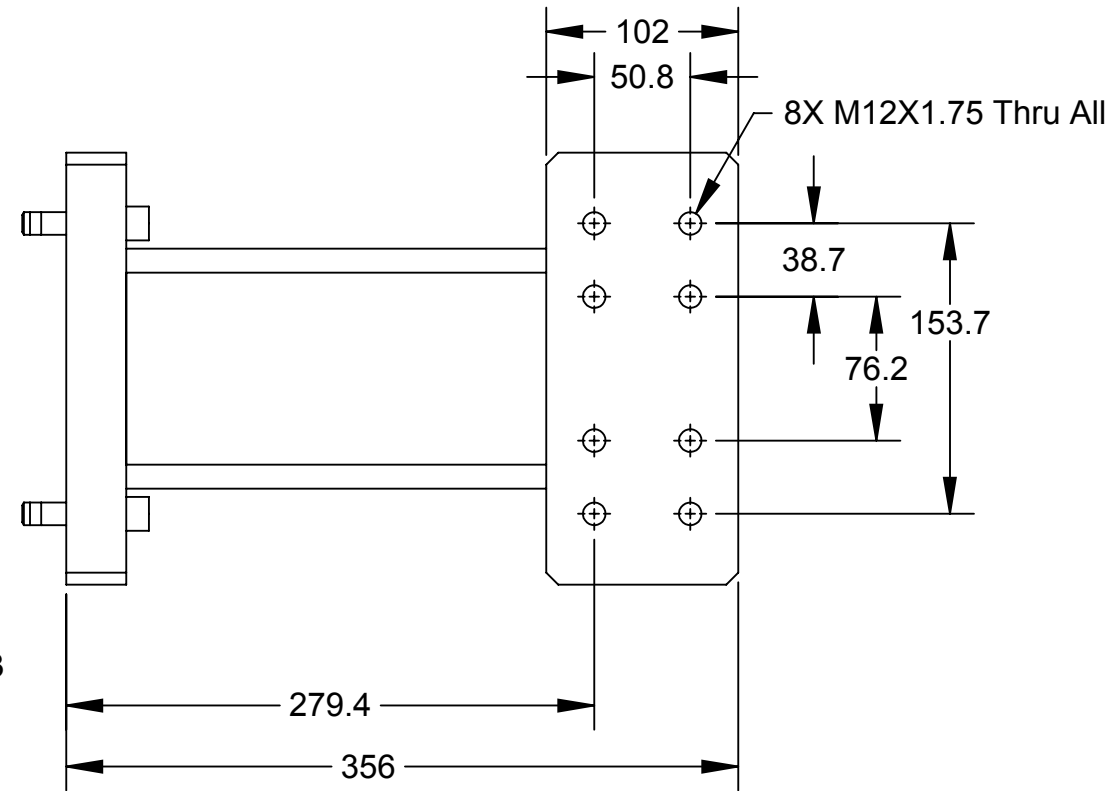
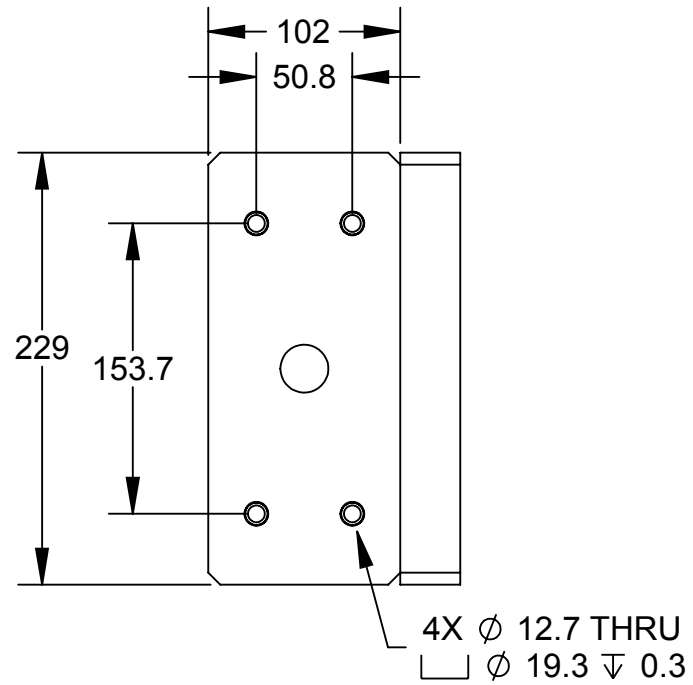
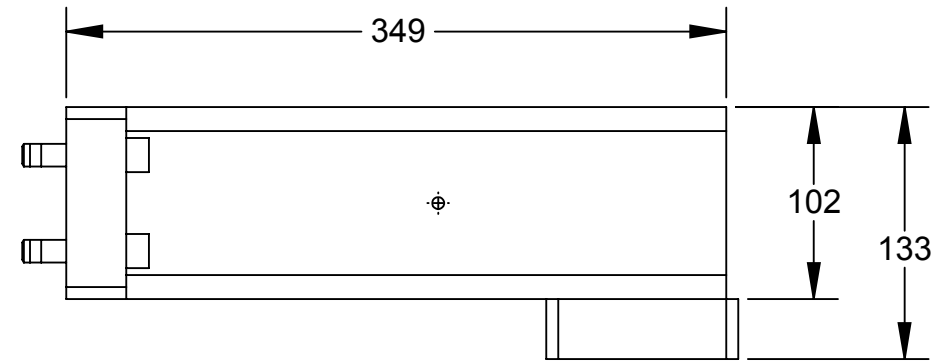

1031 Goodworth Drive, Apex, NC 27539, USA
 Tel: +1.919.772.0115 Email: info@ati-ia.com
 Fax: +1.919.772.8259 www.ati-ia.com
 ISO 9001 Registered Company

PROPERTY OF ATI INDUSTRIAL AUTOMATION, INC. NOT TO BE REPRODUCED IN ANY MANNER EXCEPT ON ORDER OR WITH PRIOR WRITTEN AUTHORIZATION OF ATI.

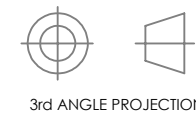

| | | | |
|------------------------------------|--------------|------------------------------------|----------|
| DRAWN BY: E. Donkor 10/30/2013 | | TITLE | |
| CHECKED BY: J. Winterroth, 1/09/14 | | TSL Horizontal Extension, 12", 90° | |
| PROJECT # - | SHEET 1 OF 1 | SCALE | SIZE |
| | | 1:4 | B |
| | | DRAWING NUMBER | REVISION |
| | | 9630-20-TSL-HE12A-7572 | 02 |