

REV.	DESCRIPTION	INITIATOR	DATE
02	ECO 16825; 3405-2220016-01 WAS 3405-2230003-01 2X 1/4" UNIFIT X 8mm TUBE SPEED CONTROLLER, 180° SWIVEL.	LJH	6/15/18

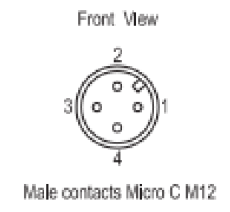
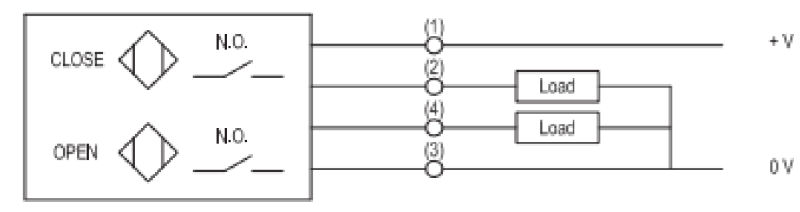
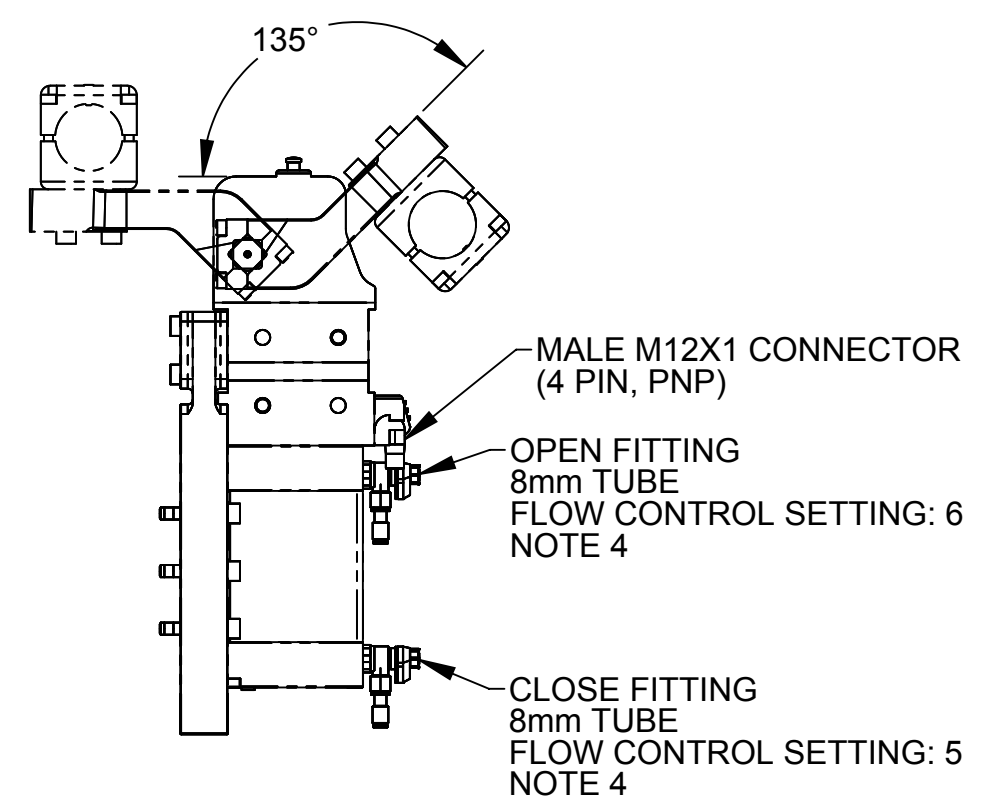
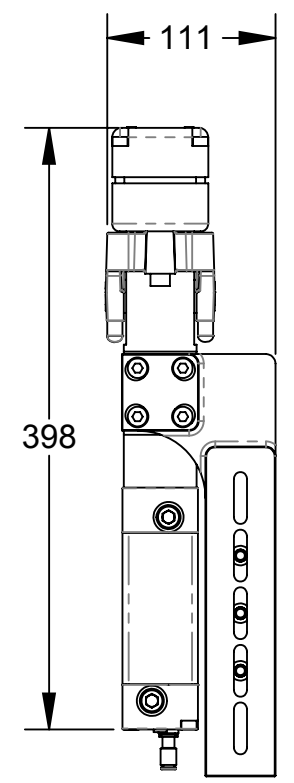
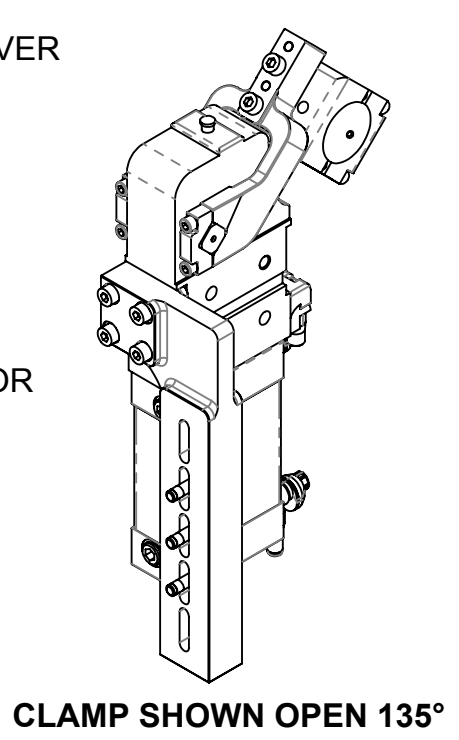
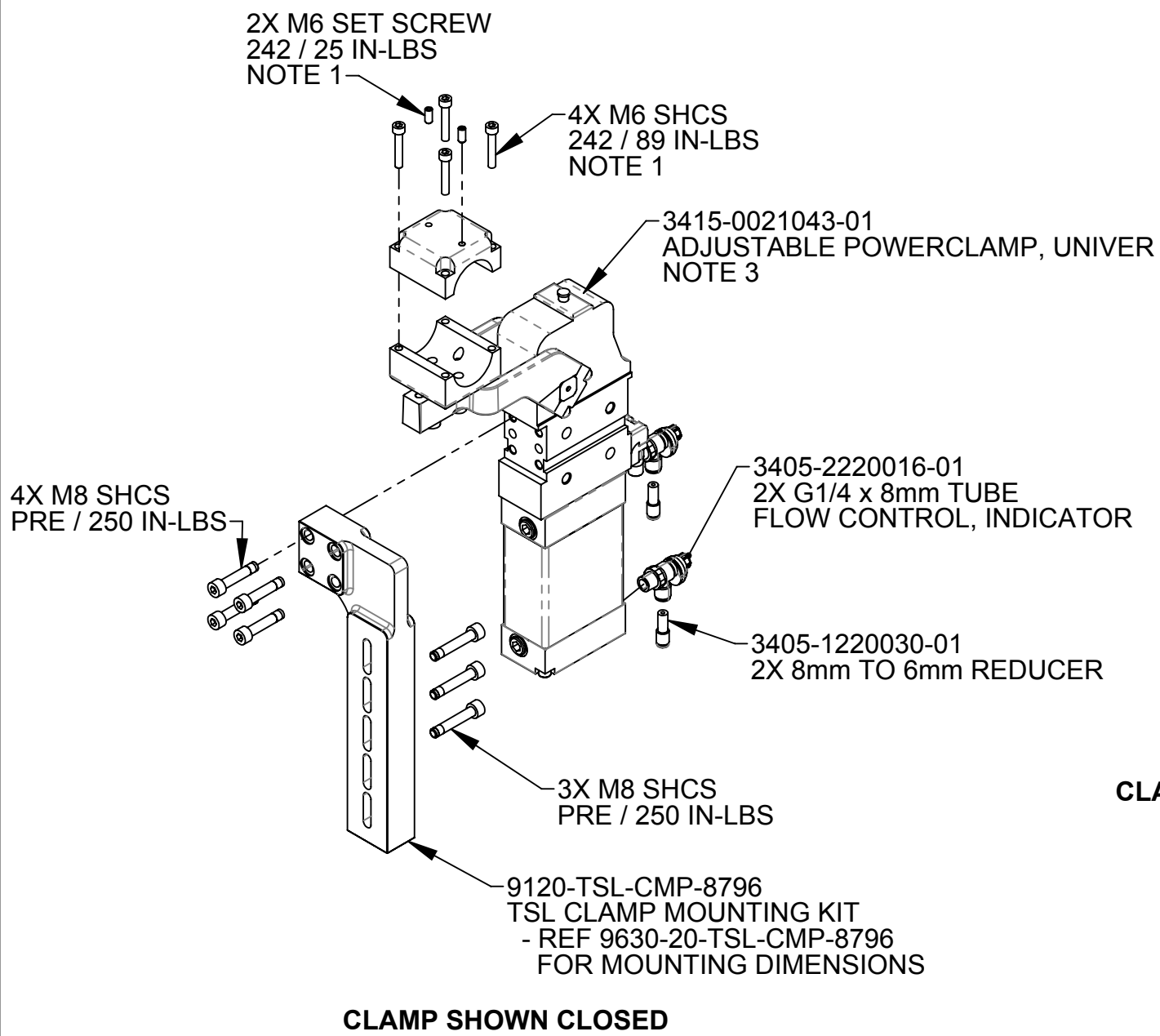

- NOTES:**
1. FASTENERS SHIPPED W/O THREAD LOCKER AND TIGHTENED TO CONTACT ONLY. CUSTOMER TO USE LOCTITE OR SIMILAR THREADLOCKER AND TORQUE FASTENERS TO LISTED TORQUE.
 2. CUSTOMER TO SUPPLY ONE INDEPENDENT, 5 PORT / 2 POSITION VALVE PER ACTUATOR FOR CONTROL. IF TWO ACTUATORS ARE USED ON A DUAL STAND, ONE VALVE MAY BE USED TO CONTROL BOTH ACTUATORS. CUSTOMER TO VERIFY CLEARANCE BETWEEN COMPONENTS BEFORE UTILIZING ONE VALVE FOR TWO ACTUATORS.
 3. CUSTOMER TO SUPPLY I/O MODULE FOR ACTUATORS, SENSORS AND VALVE CONTROL.
 4. FLOW CONTROLS ARE SHIPPED FACTORY SET. CUSTOMER TO ADJUST AS NEEDED. A HIGHER FLOW CONTROL SETTING WILL DECREASE THE OPEN/CLOSE ACTION. A LOWER FLOW CONTROL SETTING WILL INCREASE THE OPEN/CLOSE ACTION.

CLAMP POSITION SENSOR WIRING

NOTES: UNLESS OTHERWISE SPECIFIED.
DO NOT SCALE DRAWING. ALL DIMENSIONS ARE IN MILLIMETERS.



1031 Goodworth Drive, Apex, NC 27539, USA
Tel: +1.919.772.0115 Email: info@ati-ia.com
Fax: +1.919.772.8259 www.ati-ia.com
ISO 9001 Registered Company

PROPERTY OF ATI INDUSTRIAL AUTOMATION, INC. NOT TO BE REPRODUCED IN ANY MANNER EXCEPT ON ORDER OR WITH PRIOR WRITTEN AUTHORIZATION OF ATI.

DRAWN BY: D. Bohle 1/15/2018		TITLE	
CHECKED BY: J. Winterroth 1/23/2018		TSL Debris Shield Actuator - Vertical - 63mm – Adjustable Opening Angle - PNP	
PROJECT # 160202-1	SHEET 1 OF 2	SCALE 1:5	REVISION 02
		SIZE B	DRAWING NUMBER 9630-20-TSL-DSA-135-7486

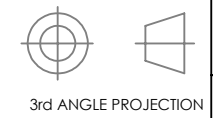

ARM ANGLE ADJUSTMENT PROCEDURE



OPENING ANGLE READOUT

CLAMP ARM

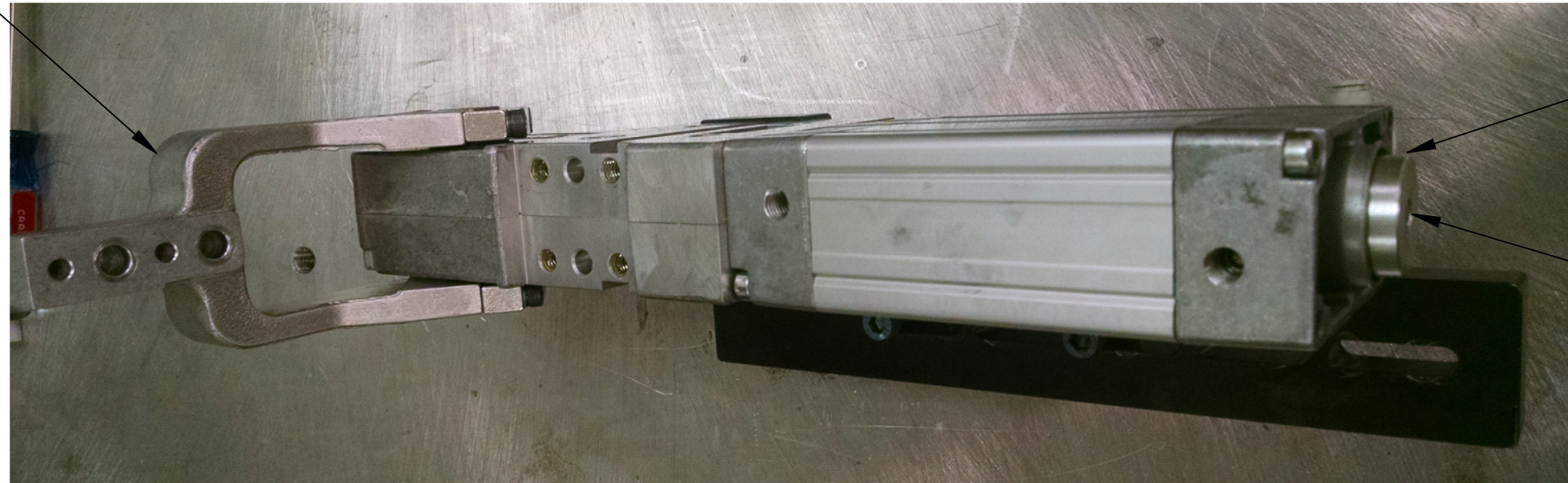

ADJUSTABLE MECHANISM

BROACH

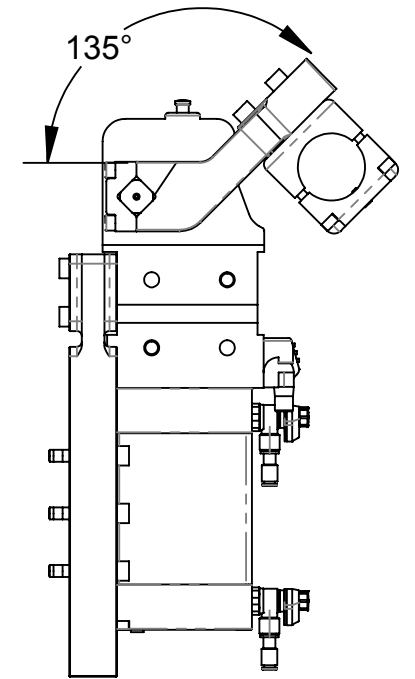

FACTORY SETTING 135°

1. ACTUATE CLAMP ARM TO FULLY OPEN POSITION (135°). THIS IS THE FACTORY SETTING.
2. TAKE AN M5 ALLEN WRENCH AND INSERT INTO BROACH ON BOTTOM OF POWER CLAMP.
3. TURN THE M5 ALLEN WRENCH COUNTER CLOCKWISE IF AN OPENING ANGLE OTHER THAN THE FACTORY SETTING IS REQUIRED.
4. REMOVE ALLEN WRENCH AND ACTUATE UNIT TO CHECK NEW OPENING ANGLE.

NOTES: UNLESS OTHERWISE SPECIFIED.

DO NOT SCALE DRAWING. ALL DIMENSIONS ARE IN MILLIMETERS.



3rd ANGLE PROJECTION



1031 Goodworth Drive, Apex, NC 27539, USA
 Tel: +1.919.772.0115 Email: info@ati-ia.com
 Fax: +1.919.772.8259 www.ati-ia.com
 ISO 9001 Registered Company

PROPERTY OF ATI INDUSTRIAL AUTOMATION, INC. NOT TO BE REPRODUCED IN ANY MANNER EXCEPT ON ORDER OR WITH PRIOR WRITTEN AUTHORIZATION OF ATI.

DRAWN BY: D. Bohle 1/15/2018		TITLE	
CHECKED BY: J. Winterroth 1/23/2018		TSL Debris Shield Actuator - Vertical - 63mm – Adjustable Opening Angle - PNP	
PROJECT # 160202-1	SHEET 2 OF 2	SCALE 1:5	SIZE B
		DRAWING NUMBER	REVISION
		9630-20-TSL-DSA-135-7486	02