

Rev.	Description	Initiator	Date
01	Initial Release	PDL	02/14/2011

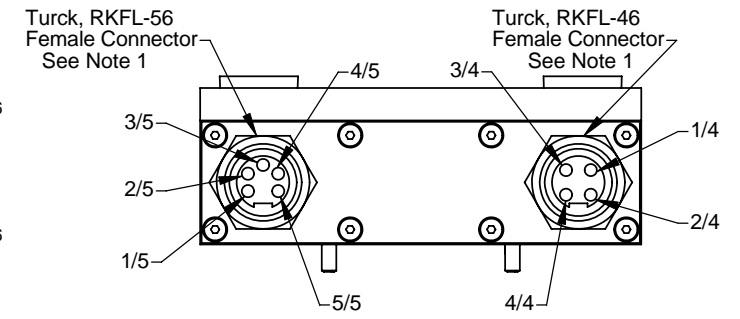
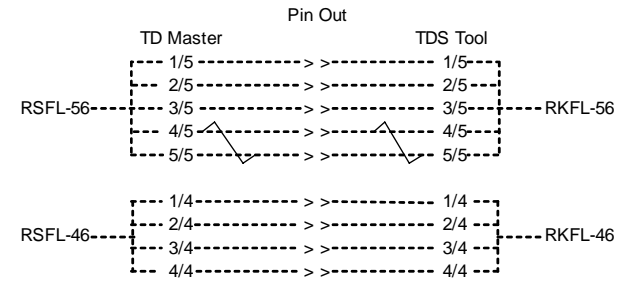
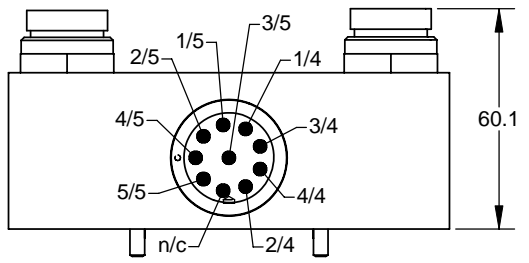
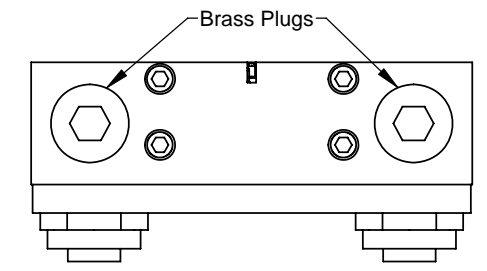
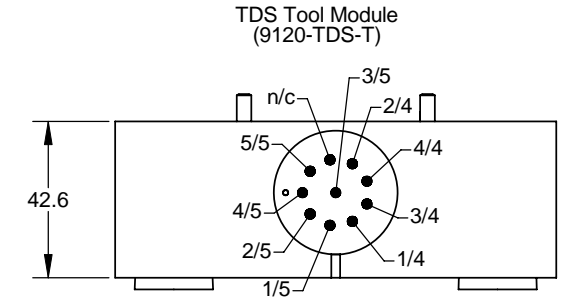
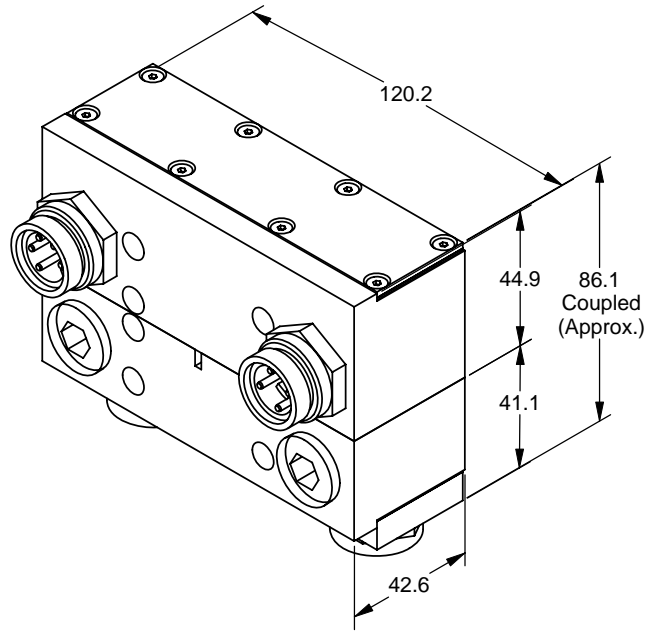
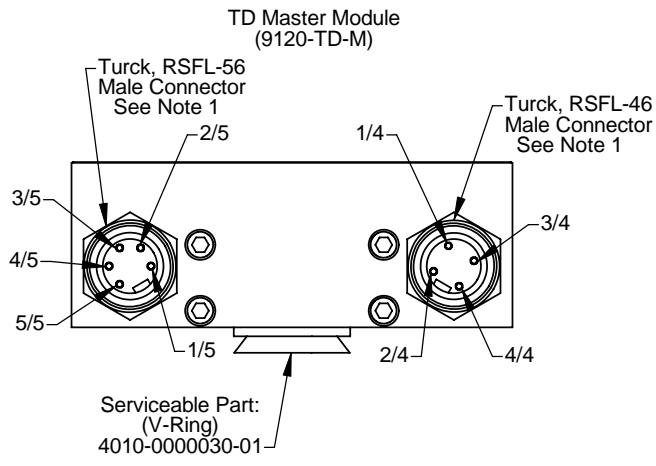

Legend: Connectors

1/5	Drain
2/5	V+
3/5	V-
4/5	CAN_H
5/5	CAN_L
1/4	Aux V+
2/4	Spare
3/4	Spare
4/4	Aux V-

Notes:
1. Connector orientation is not guaranteed.

NOTES: UNLESS OTHERWISE SPECIFIED.
DO NOT SCALE DRAWING. ALL DIMENSIONS ARE IN MILLIMETERS.

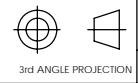

DRAWN BY: P.Luczka, 02/14/11		TITLE: TDS DeviceNet Module Drawing	
CHECKED BY: W.Berrocal, 12/14/11 A.Strotzer, 11/18/10		SCALE: 3:4	REVISION: 01
PROJECT # 101111-1	SHEET 1 OF 1	SIZE: B	DRAWING NUMBER: 9630-20-TDS

1031 Goodworth Drive, Apex, NC 27539, USA
Tel: +1.919.772.0115 Email: info@ati-ia.com
Fax: +1.919.772.8259 www.ati-ia.com
ISO 9001 Registered Company

PROPERTY OF ATI INDUSTRIAL AUTOMATION, INC. NOT TO BE REPRODUCED IN ANY MANNER EXCEPT ON ORDER OR WITH PRIOR WRITTEN AUTHORIZATION OF ATI.