

# "DANGER!" - Electrical Shock Hazard

This module has a Voltage of 50V or greater, NO contact should be attempted before removing power. This especially includes separation or insertion of the mating connectors or any contact with the tool changer or its components.

Rev.	Description	Initiator	Date
03	Eco 14209; Removed Cleat Assemblies from model and drawing. Added Electrical Shock Hazard Note.	CF	2/9/2016

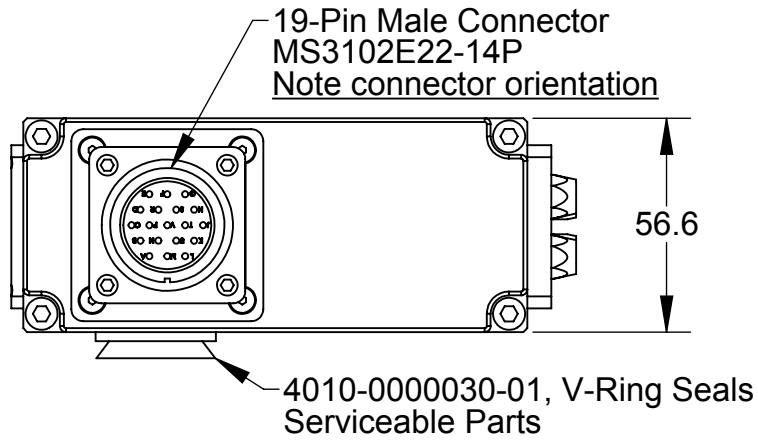

**9121-SA12-M**

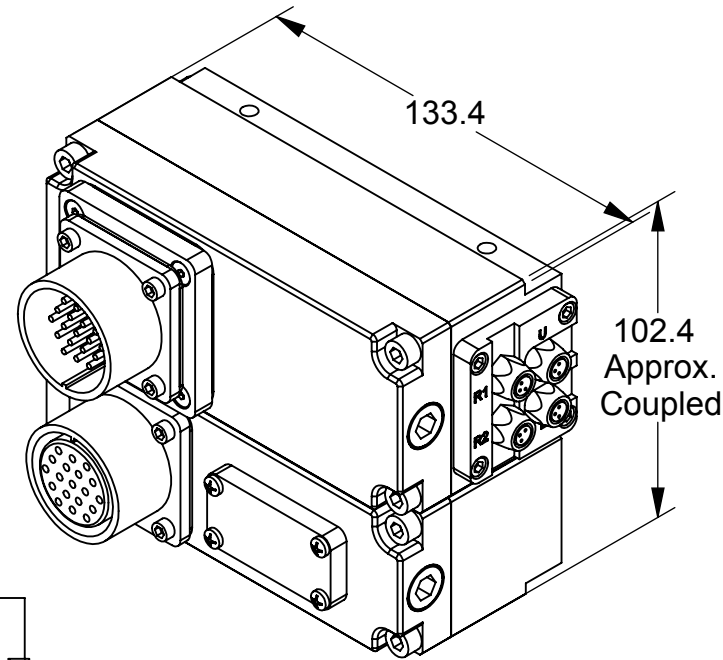

**SA12 Master and SA2 Tool Coupled**

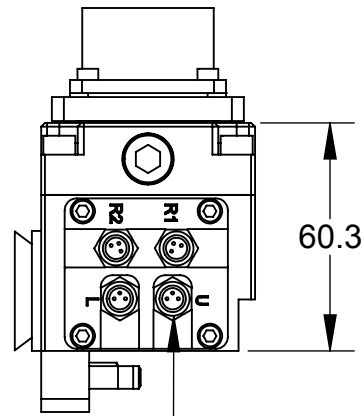
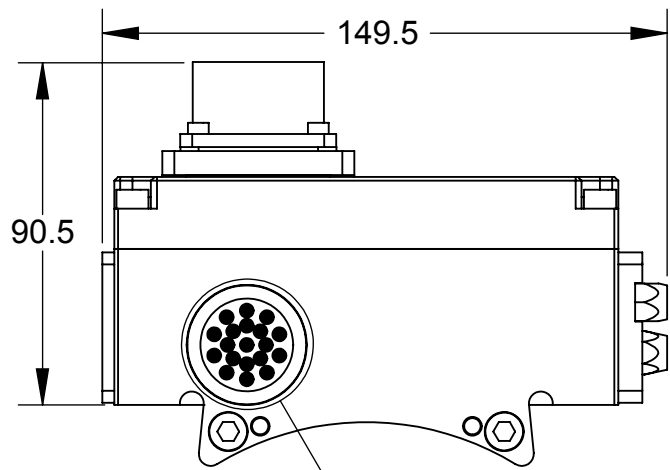

RTL, Lock, and Unlock  
Sensor Connectors  
4X Turck MFKS 3

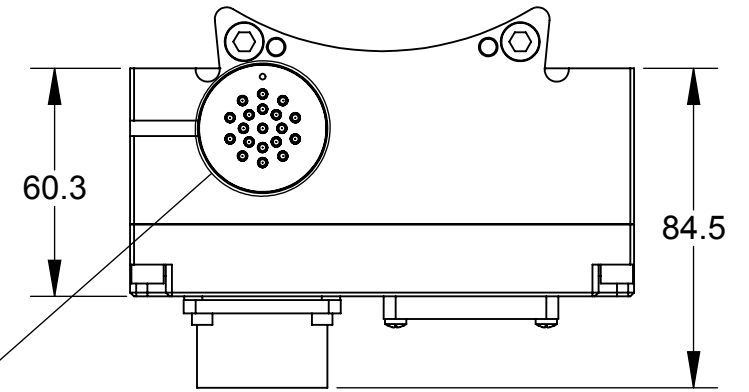

19-Pin Female Connector  
MS3102E22-14S  
Note connector orientation

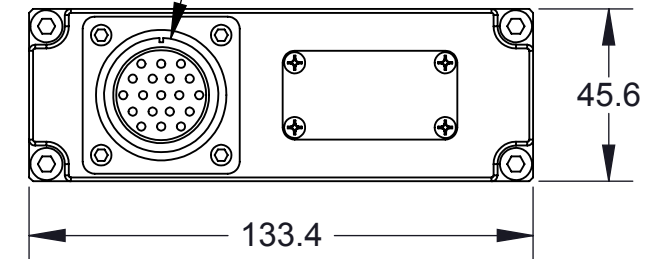

**9121-SA2-T**

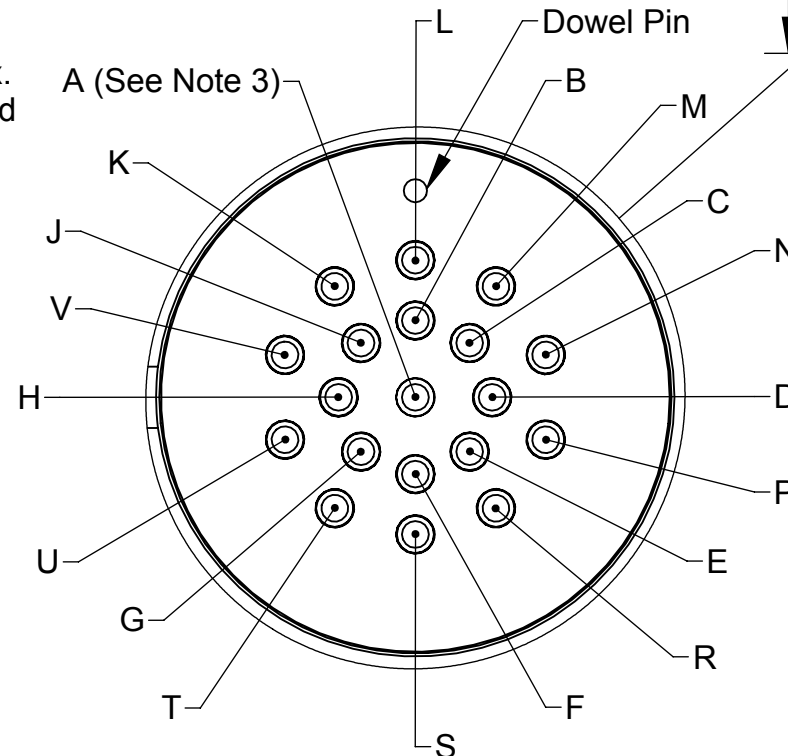

**Tool Side Pin Block**  
DETAIL B  
SCALE 2 : 1

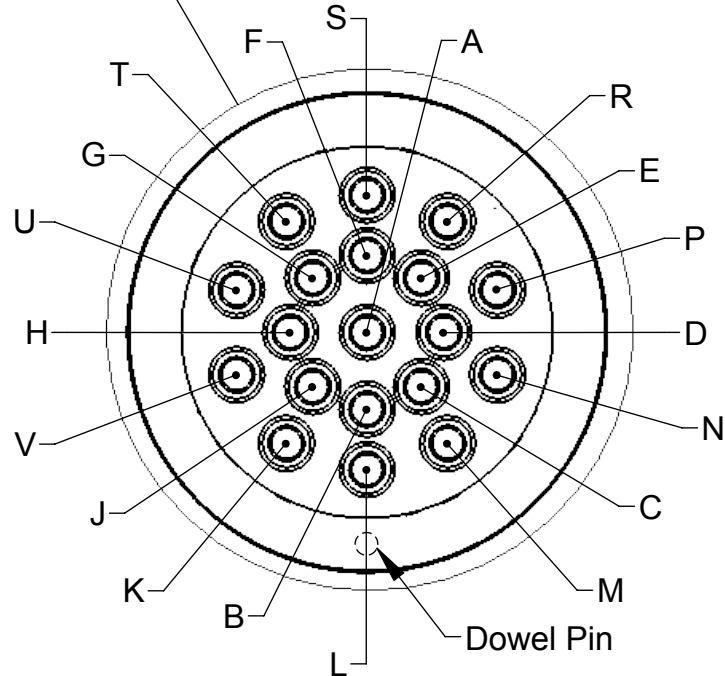

**Master Side Pin Block**  
DETAIL A  
SCALE 2 : 1

### Notes:

- Connector details and pin assignment information on Sheet 2.
- Electrical schematic and functional notes on Sheet 3.
- Pin A is first mate and last break during a tool change and is specified for use 0 VDC.

NOTES: UNLESS OTHERWISE SPECIFIED.

DO NOT SCALE DRAWING. ALL DIMENSIONS ARE IN MILLIMETERS.



3rd ANGLE PROJECTION



1031 Goodworth Drive, Apex, NC 27539, USA  
Tel: +1.919.772.0115 Email: info@ati-ia.com  
Fax: +1.919.772.8259 www.ati-ia.com  
ISO 9001 Registered Company

PROPERTY OF ATI INDUSTRIAL AUTOMATION, INC. NOT TO BE REPRODUCED IN ANY MANNER EXCEPT ON ORDER OR WITH PRIOR WRITTEN AUTHORIZATION OF ATI.

DRAWN BY: W. Berrocal, 2/22/11

CHECKED BY: D. Mushow, 2/23/11

PROJECT # 110222-1 SHEET 1 OF 3

TITLE

SA12-M/SA2-T Customer Drawing

SCALE  
2:3

SIZE  
B

DRAWING NUMBER  
9630-20-SA12M SA2T

REVISION  
03

Rev.	Description	Initiator	Date
-	See Sheet1	-	-

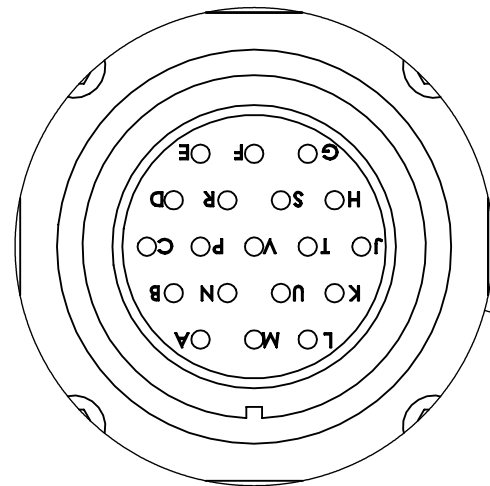

19-Pin Male Connector  
MS3102E22-14P  
Face View  
Scale 3:2

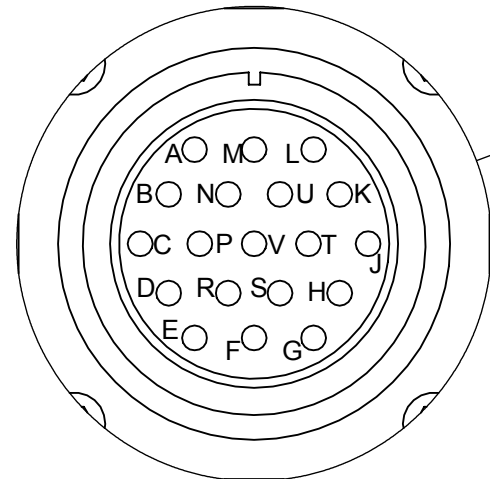

19-Pin Female Connector  
MS3102E22-14S  
Face View  
Scale 3:2

9121-SA12-M

Note connector orientation

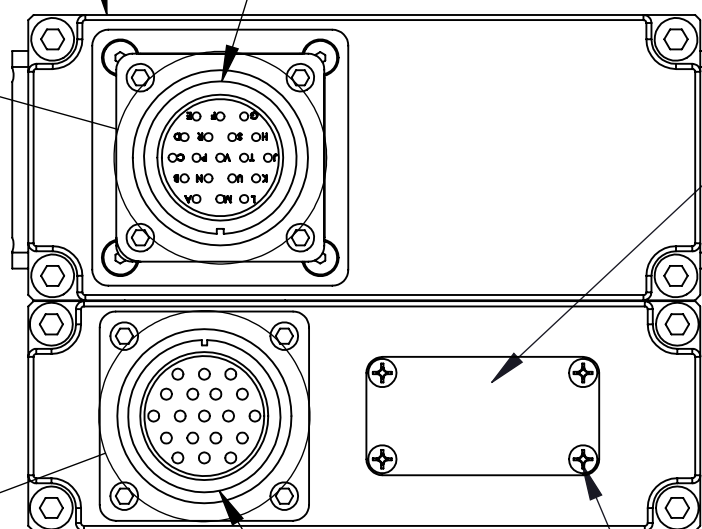

3700-20-2696, Thick Window Serviceable Part

9121-SA2-T

Note connector orientation

(4) 3500-9957012-21, M3 x 12 Slotted Screw, SS Serviceable Part

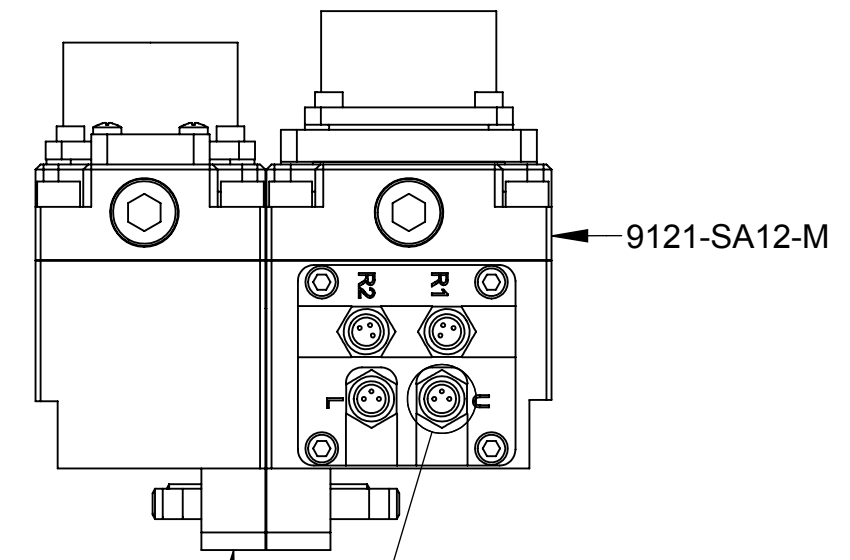

9121-SA2-T

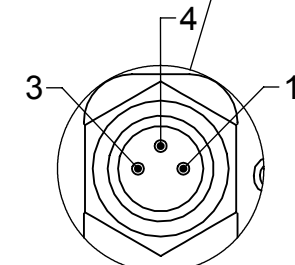

Sensor Connectors  
4X Turck MFKS  
Face View  
Scale 2:1

NOTES: UNLESS OTHERWISE SPECIFIED.

DO NOT SCALE DRAWING. ALL DIMENSIONS ARE IN MILLIMETERS.

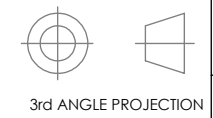

1031 Goodworth Drive, Apex, NC 27539, USA  
Tel: +1.919.772.0115 Email: info@ati-ia.com  
Fax: +1.919.772.8259 www.ati-ia.com  
ISO 9001 Registered Company

PROPERTY OF ATI INDUSTRIAL AUTOMATION, INC. NOT TO BE REPRODUCED IN ANY MANNER EXCEPT ON ORDER OR WITH PRIOR WRITTEN AUTHORIZATION OF ATI.

DRAWN BY: W. Berrocal, 2/22/11

CHECKED BY: D. Mushow, 2/23/11

PROJECT # 110222-1 SHEET 2 OF 3

TITLE		SCALE		SIZE	DRAWING NUMBER	REVISION
SA12-M/SA2-T Customer Drawing		2:3		B	9630-20-SA12M SA2T	03

Rev.	Description	Initiator	Date
-	See Sheet1	-	-

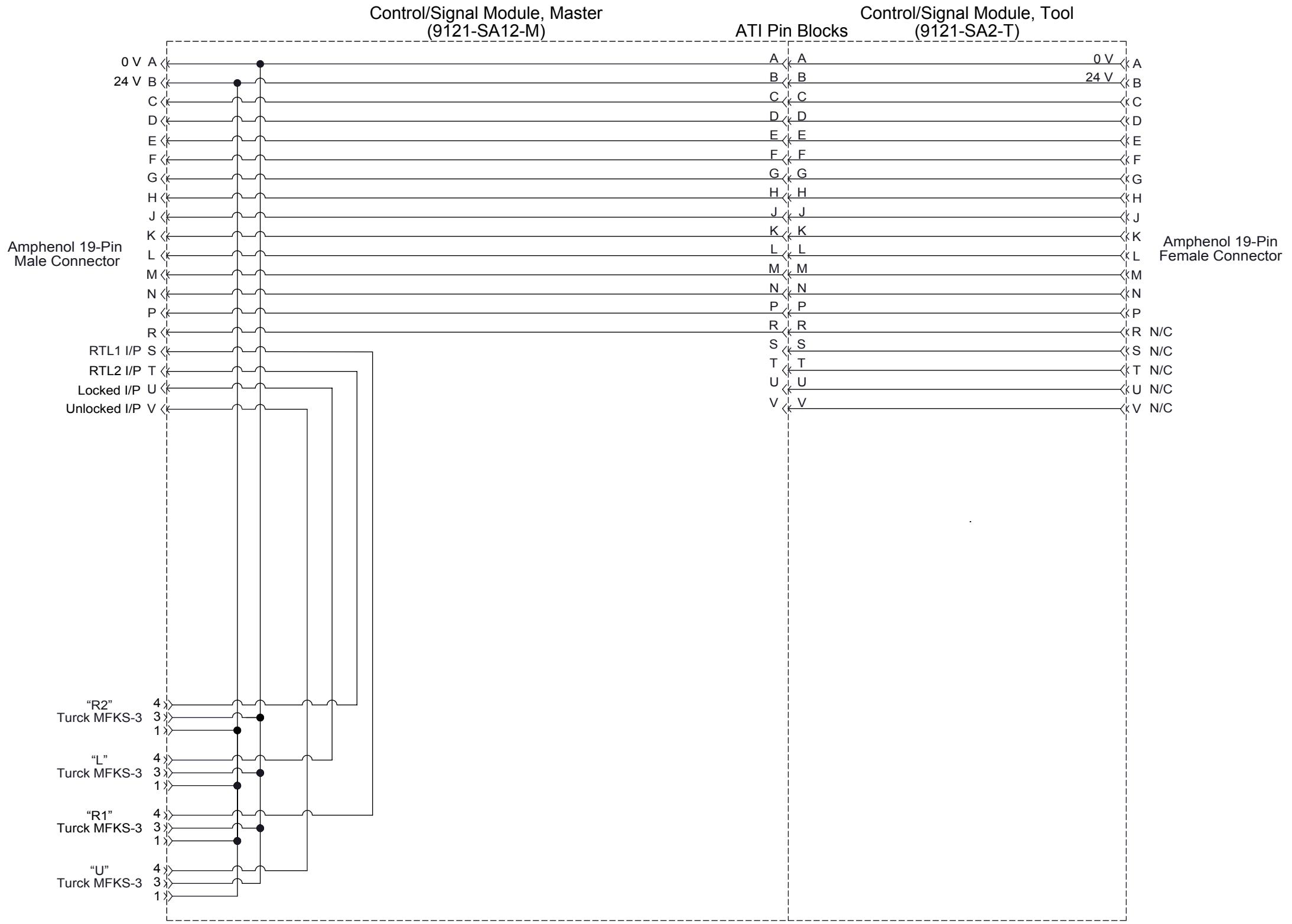

Notes:  
 1. The complete tool changer package comes equipped with external cables that are connected to the sensors.

NOTES: UNLESS OTHERWISE SPECIFIED.  
 DO NOT SCALE DRAWING. ALL DIMENSIONS ARE IN MILLIMETERS.

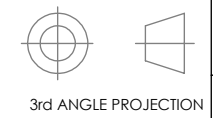

1031 Goodworth Drive, Apex, NC 27539, USA  
 Tel: +1.919.772.0115 Email: info@ati-ia.com  
 Fax: +1.919.772.8259 www.ati-ia.com  
 ISO 9001 Registered Company

PROPERTY OF ATI INDUSTRIAL AUTOMATION, INC. NOT TO BE REPRODUCED IN ANY MANNER EXCEPT ON ORDER OR WITH PRIOR WRITTEN AUTHORIZATION OF ATI.

DRAWN BY: W. Berrocal, 2/22/11		TITLE	
CHECKED BY: D. Mushow, 2/23/11		SA12-M/SA2-T Customer Drawing	
PROJECT # 110222-1	SHEET 3 OF 3	SCALE 1:1	SIZE B
DRAWING NUMBER 9630-20-SA12M SA2T		REVISION 03	