

Rev.	Description	Initiator	Date
01P	Initial design.	MH	3/14/2013
02P	Fixed Mate	RMH	6/24/2013
03P	Hide O-ring	RMH	6/24/2013
04	Release	RMH	6/24/2013

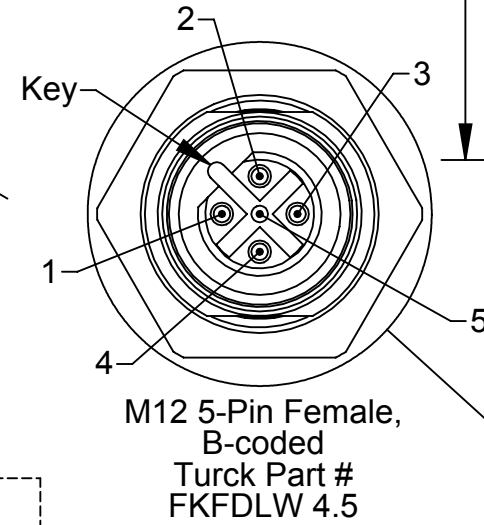

**ELECTRICAL SCHEMATIC**

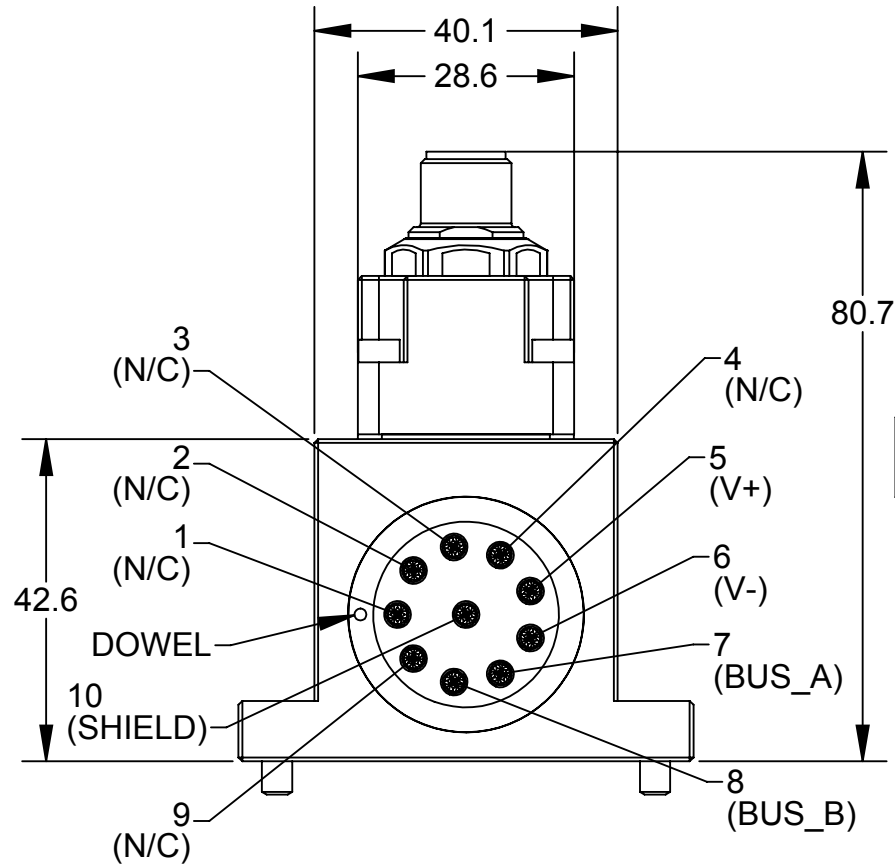
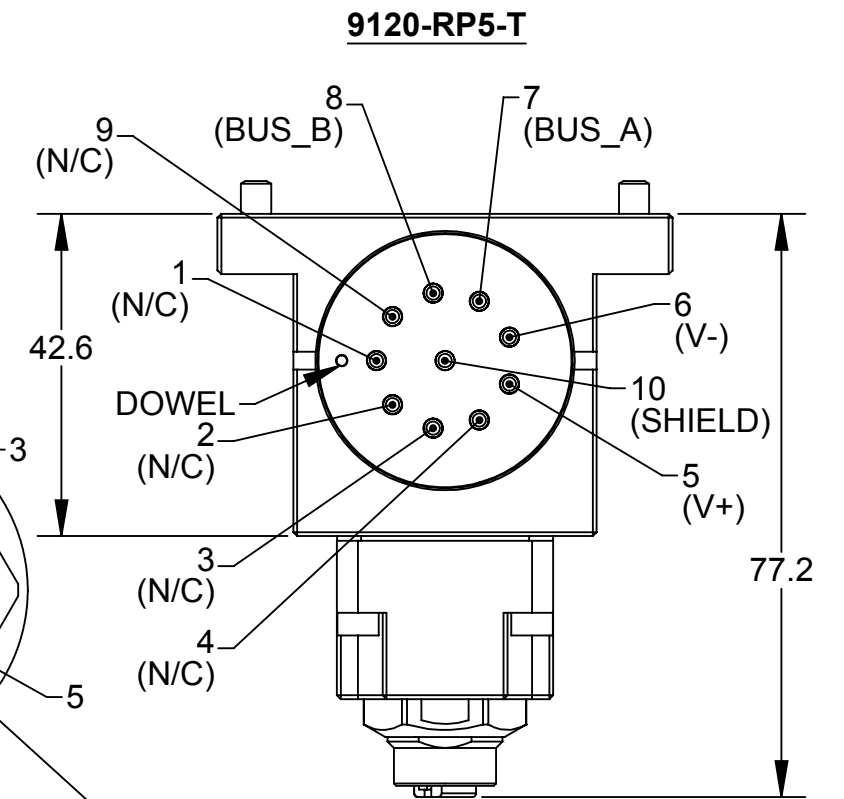
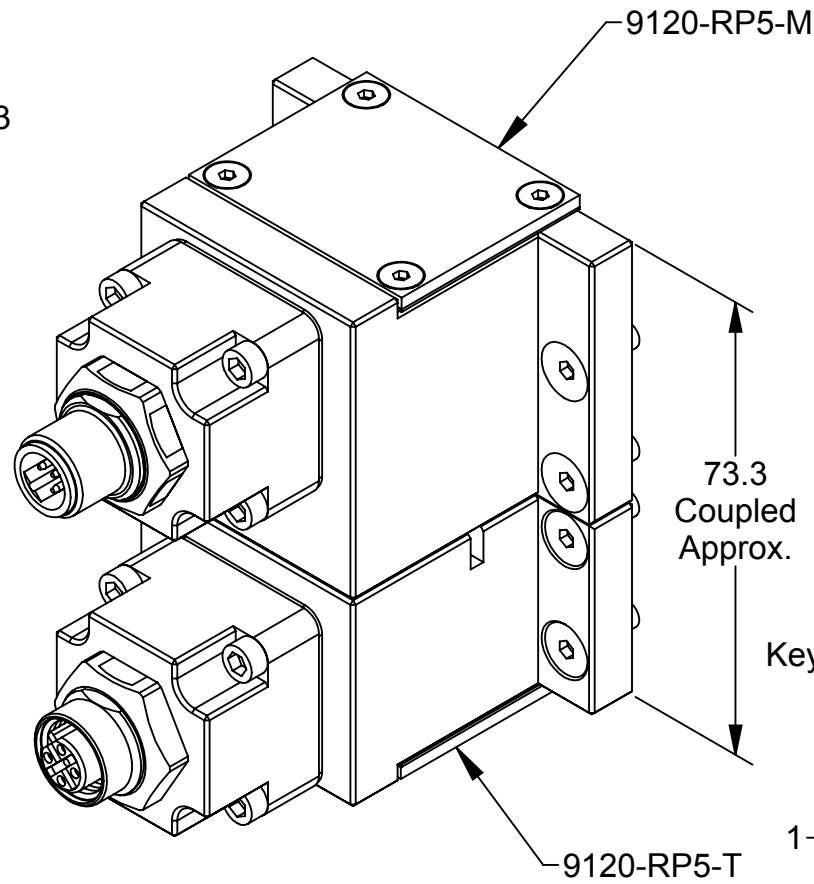
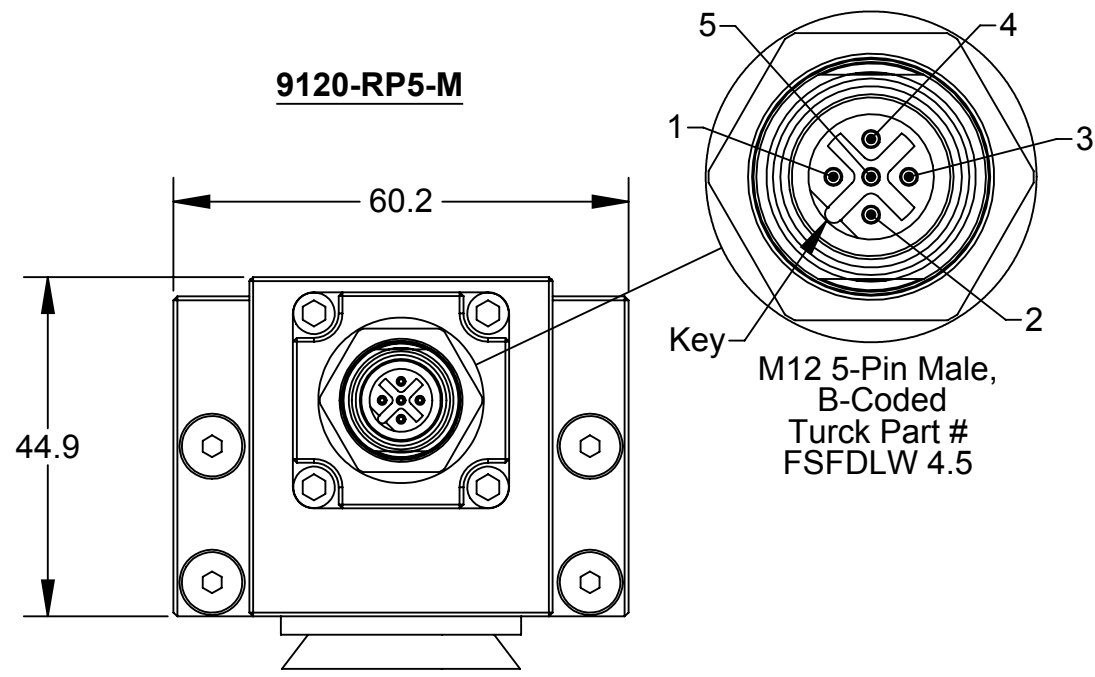
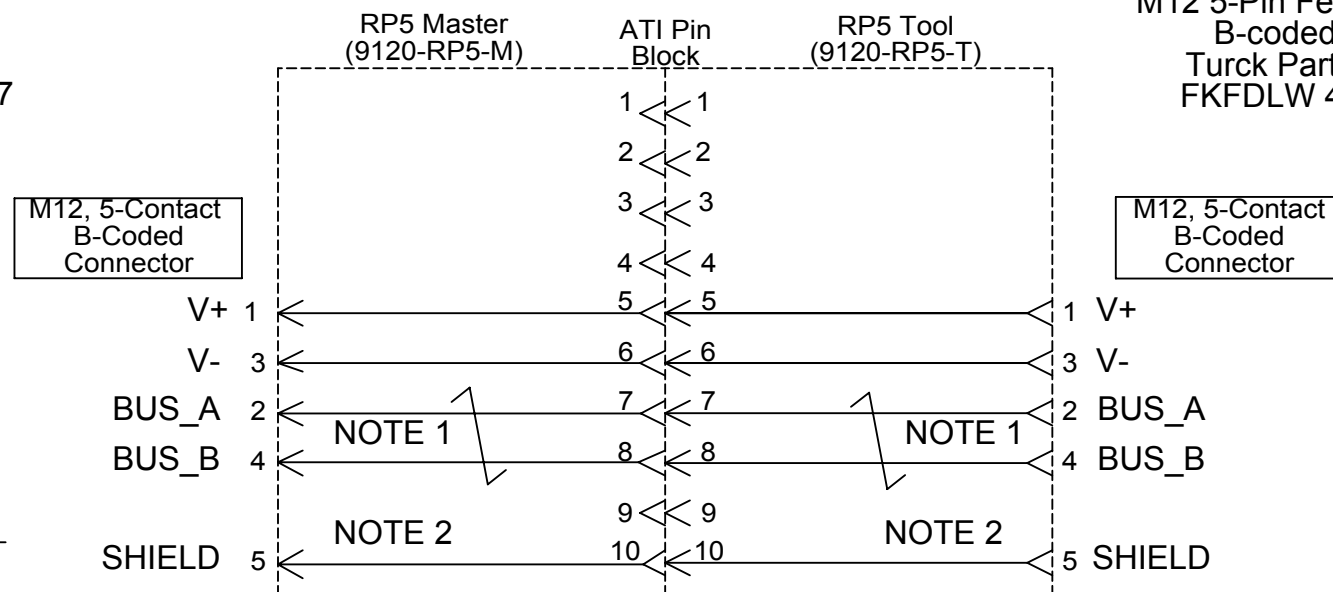

- Notes:**
- Twisted wire pair is maintained through the Master and Tool on pins 7-8.
  - The shield is passed from Master to Tool via Pin 10 of the 10-Pin Pin Block.

NOTES: UNLESS OTHERWISE SPECIFIED.

DO NOT SCALE DRAWING. ALL DIMENSIONS ARE IN MILLIMETERS.



3rd ANGLE PROJECTION



1031 Goodworth Drive, Apex, NC 27539, USA  
 Tel: +1.919.772.0115 Email: info@ati-ia.com  
 Fax: +1.919.772.8259 www.ati-ia.com  
 ISO 9001 Registered Company

PROPERTY OF ATI INDUSTRIAL AUTOMATION, INC. NOT TO BE REPRODUCED IN ANY MANNER EXCEPT ON ORDER OR WITH PRIOR WRITTEN AUTHORIZATION OF ATI.

DRAWN BY: M.Hallmark, 3/15/2013		TITLE	
CHECKED BY: W.Berrocal, 3/15/2013 A. Strotzer, 4/2/2013		RP5 Customer Drawing	
PROJECT # 130205-1	SHEET 1 OF 1	SCALE 1:1	SIZE B
DRAWING NUMBER 9630-20-RP5		REVISION 04	