

Rev.	Description	Initiator	Date
03	Eco 18477; Removed note 3, added "Note Connector Orientation".	LJH	11/11/19

### 9120-RF5-M Master Module

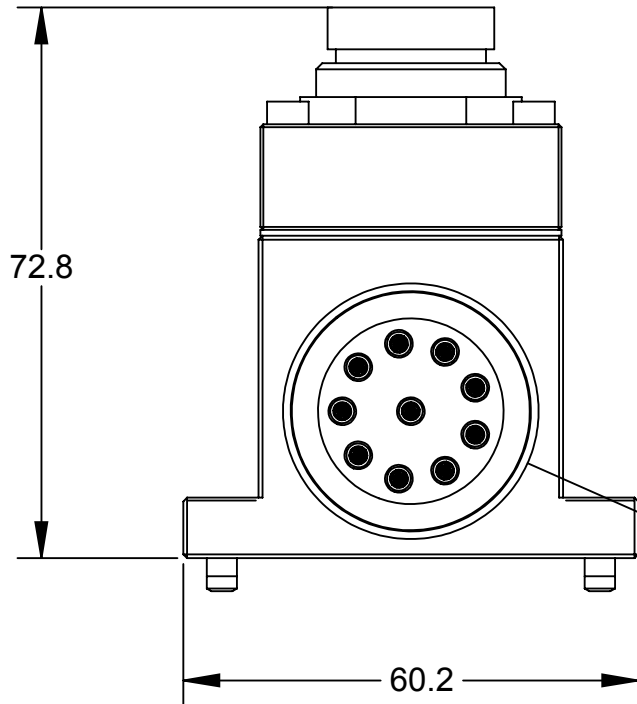

- Notes:
- Pin 10 is first to mate and last to brake contact.
  - Rating: 9A / 250VAC

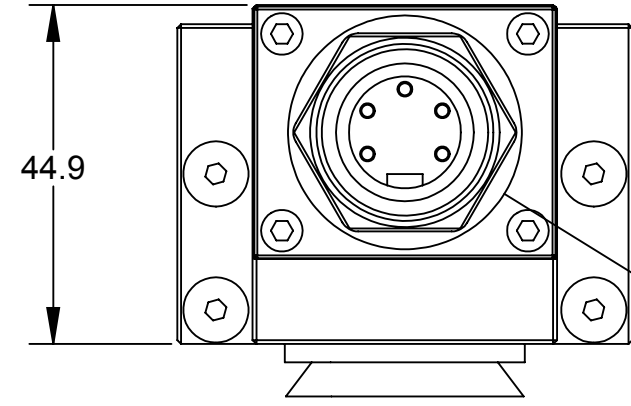
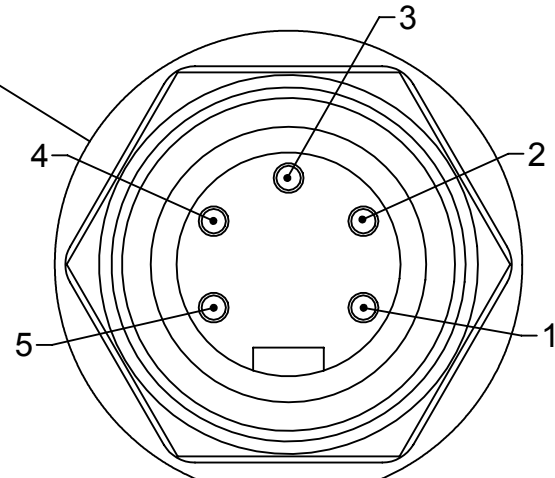

Turck RSFL56-U5229-12  
5-Pin Male Connector  
SCALE 2 : 1  
Note Connector Orientation

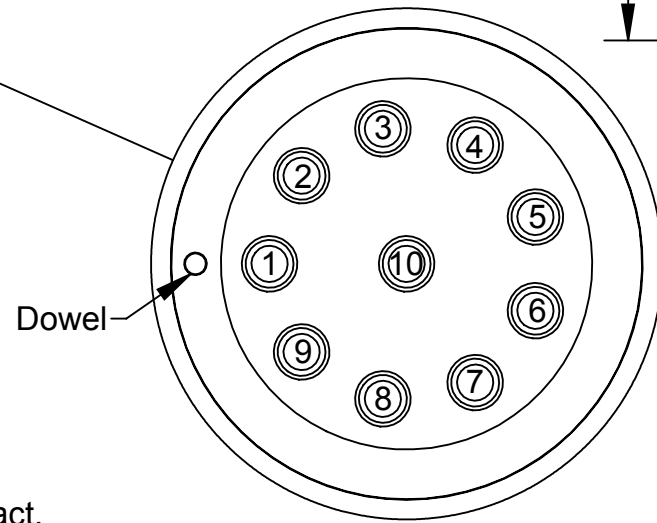

10-Pin Master Pin Block  
SCALE 2 : 1

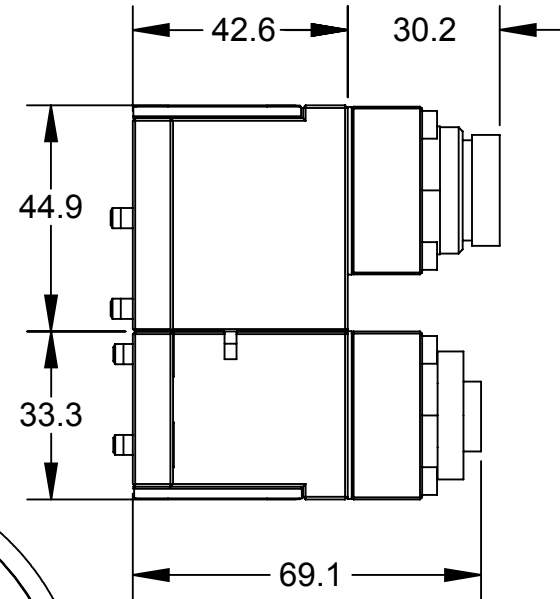
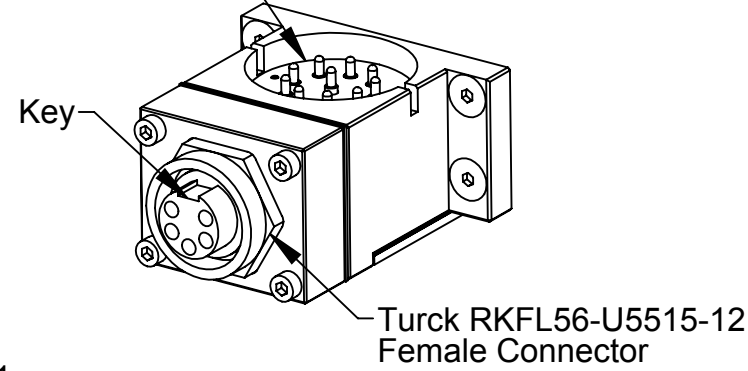
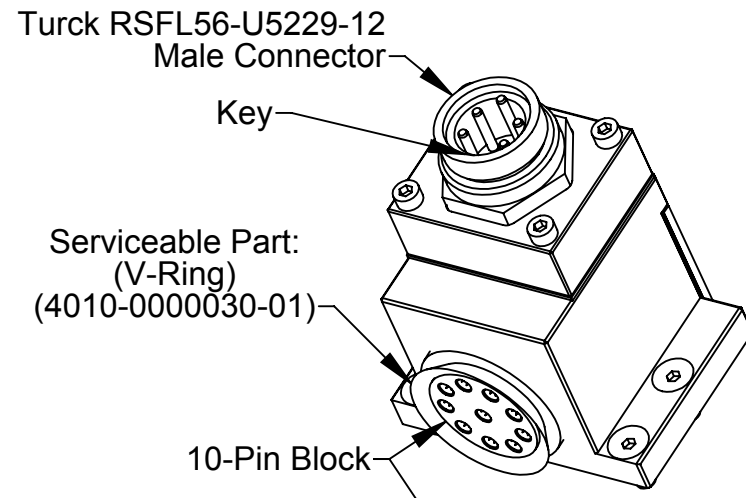

### 9120-RF5-T Tool Module

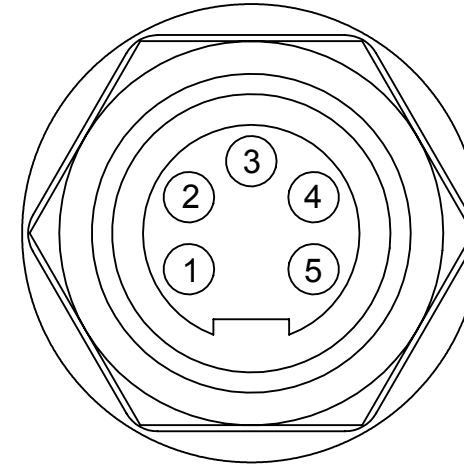

Turck RKFL56-U5515-12  
5-Pin Female Connector  
SCALE 2 : 1  
Note Connector Orientation

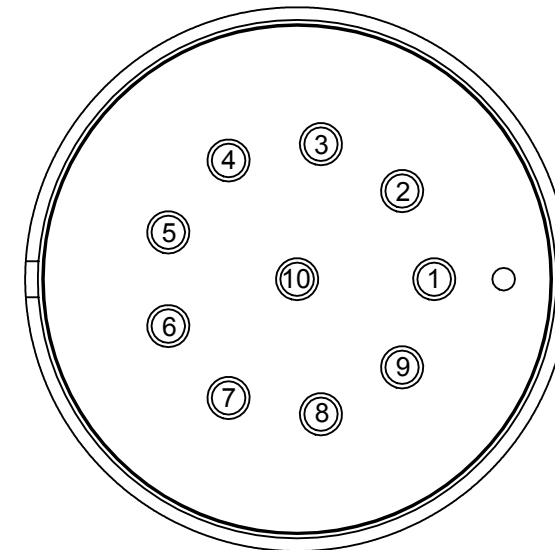

10-Pin Tool Pin Block  
SCALE 2 : 1

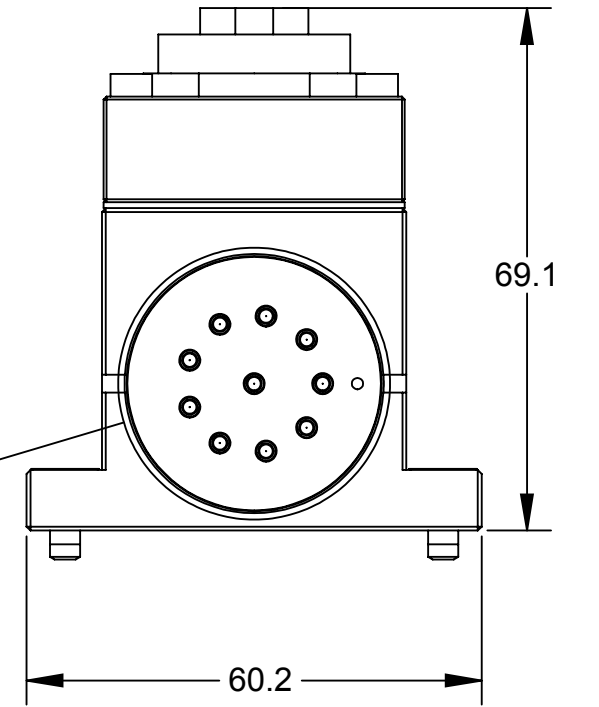
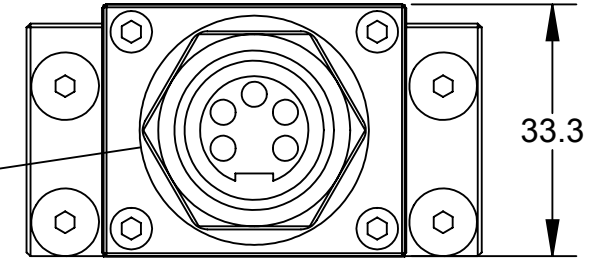

NOTES: UNLESS OTHERWISE SPECIFIED.

DO NOT SCALE DRAWING. ALL DIMENSIONS ARE IN MILLIMETERS.



3rd ANGLE PROJECTION



1031 Goodworth Drive, Apex, NC 27539, USA  
Tel: +1.919.772.0115 Email: info@ati-ia.com  
Fax: +1.919.772.8259 www.ati-ia.com  
ISO 9001 Registered Company

PROPERTY OF ATI INDUSTRIAL AUTOMATION, INC. NOT TO BE REPRODUCED IN ANY MANNER EXCEPT ON ORDER OR WITH PRIOR WRITTEN AUTHORIZATION OF ATI.

DRAWN BY: A. Takla, 10/18/12		TITLE	
CHECKED BY: W. Berrocal, 10/18/12 L. Costello, 10/18/12		RF5 Module Customer Drawing	
PROJECT #	120926-3	SHEET	1 OF 2
SCALE	1:2	SIZE	B
DRAWING NUMBER	9630-20-RF5	REVISION	03

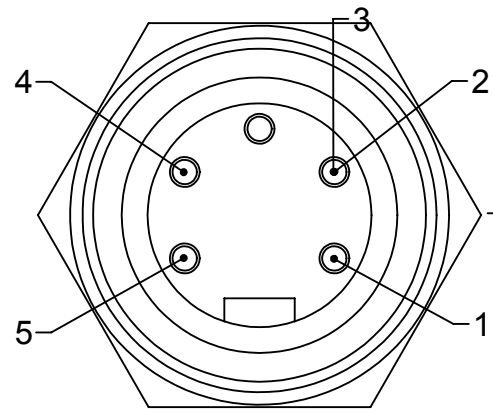

Turck RSFL56-U5229-12  
Male Connector  
SCALE 2:1

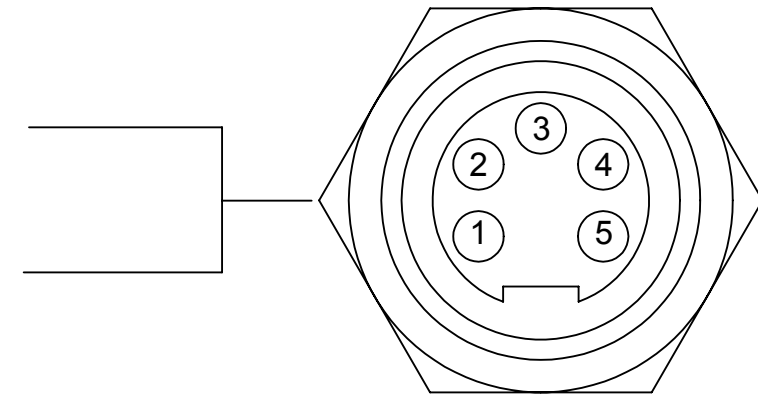
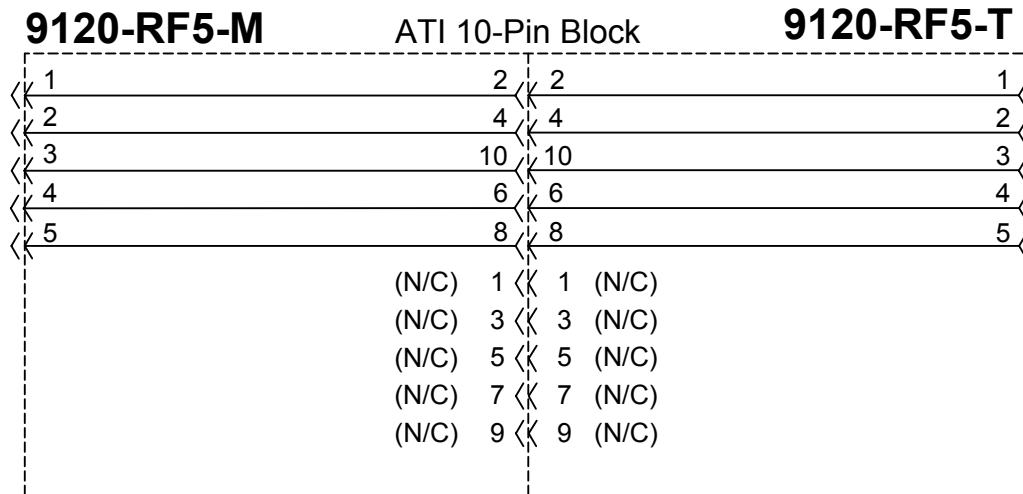
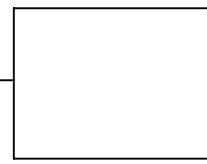

Turck RKFL56-U5515-12  
Female Connector  
SCALE 2:1

NOTES: UNLESS OTHERWISE SPECIFIED.

DO NOT SCALE DRAWING. ALL DIMENSIONS ARE IN MILLIMETERS.



3rd ANGLE PROJECTION



1031 Goodworth Drive, Apex, NC 27539, USA  
Tel: +1.919.772.0115 Email: info@ati-ia.com  
Fax: +1.919.772.8259 www.ati-ia.com  
ISO 9001 Registered Company

PROPERTY OF ATI INDUSTRIAL AUTOMATION, INC. NOT TO BE REPRODUCED IN ANY MANNER EXCEPT ON ORDER OR WITH PRIOR WRITTEN AUTHORIZATION OF ATI.

DRAWN BY: A. Takla, 10/18/12		TITLE		
CHECKED BY: W. Berrocal, 10/18/12 L. Costello, 10/18/12		RF5 Module Customer Drawing		
PROJECT #	120926-3	SHEET	2	OF 2
SCALE	1:1	SIZE	B	DRAWING NUMBER
				9630-20-RF5
				REVISION
				03