

Rev.	Description	Initiator	Date
01P	Initial Design	AAT	01/21/2014
02	Production Release	AAT	05/12/2014

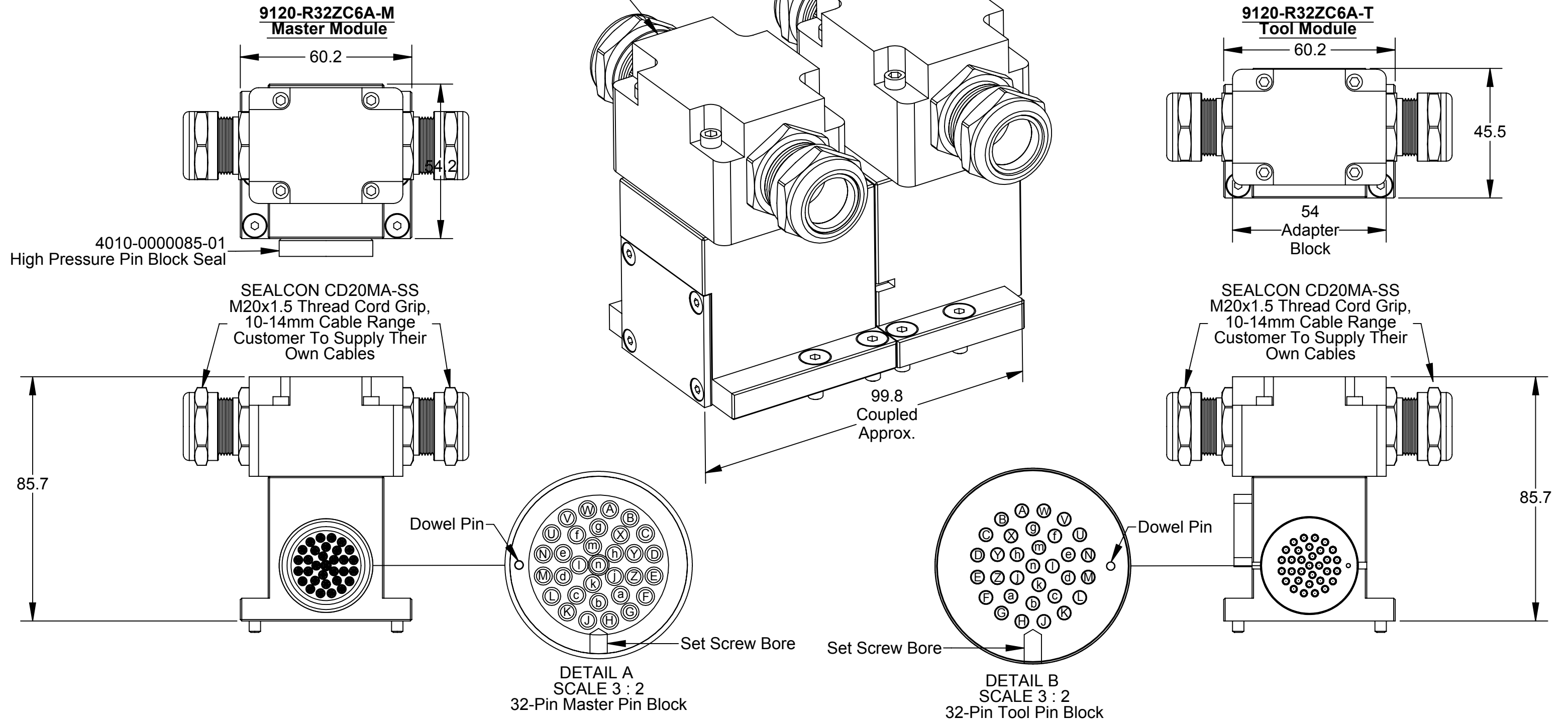

- Notes:
1. The R32ZC6A Master and Tool Module Pin Blocks are rated to 6A.
  2. Customer is responsible for supplying, wiring and securing cables to R32ZC6A Modules.
  3. For wet working conditions, it is strongly recommended that the R32ZC6A Modules be potted.

NOTES: UNLESS OTHERWISE SPECIFIED.

DO NOT SCALE DRAWING. ALL DIMENSIONS ARE IN MILLIMETERS.



3rd ANGLE PROJECTION



1031 Goodworth Drive, Apex, NC 27539, USA  
 Tel: +1.919.772.0115 Email: info@ati-ia.com  
 Fax: +1.919.772.8259 www.ati-ia.com  
 ISO 9001 Registered Company

PROPERTY OF ATI INDUSTRIAL AUTOMATION, INC. NOT TO BE REPRODUCED IN ANY MANNER EXCEPT ON ORDER OR WITH PRIOR WRITTEN AUTHORIZATION OF ATI.

DRAWN BY: A. Takla, 01/21/14		TITLE	
CHECKED BY: W. Berrocal, 01/28/14 A. Strotzer, 01/28/14		R32ZC6A Module Customer Drawing	
PROJECT # 140110-1	SHEET 1 OF 2	SCALE 1:2	REVISION 02
DRAWING NUMBER 9630-20-R32ZC6A		SIZE B	

Rev.	Description	Initiator	Date
-	See Sheet1	-	-

9120-R32ZC6A-M Module

9120-R32ZC6A-T Module

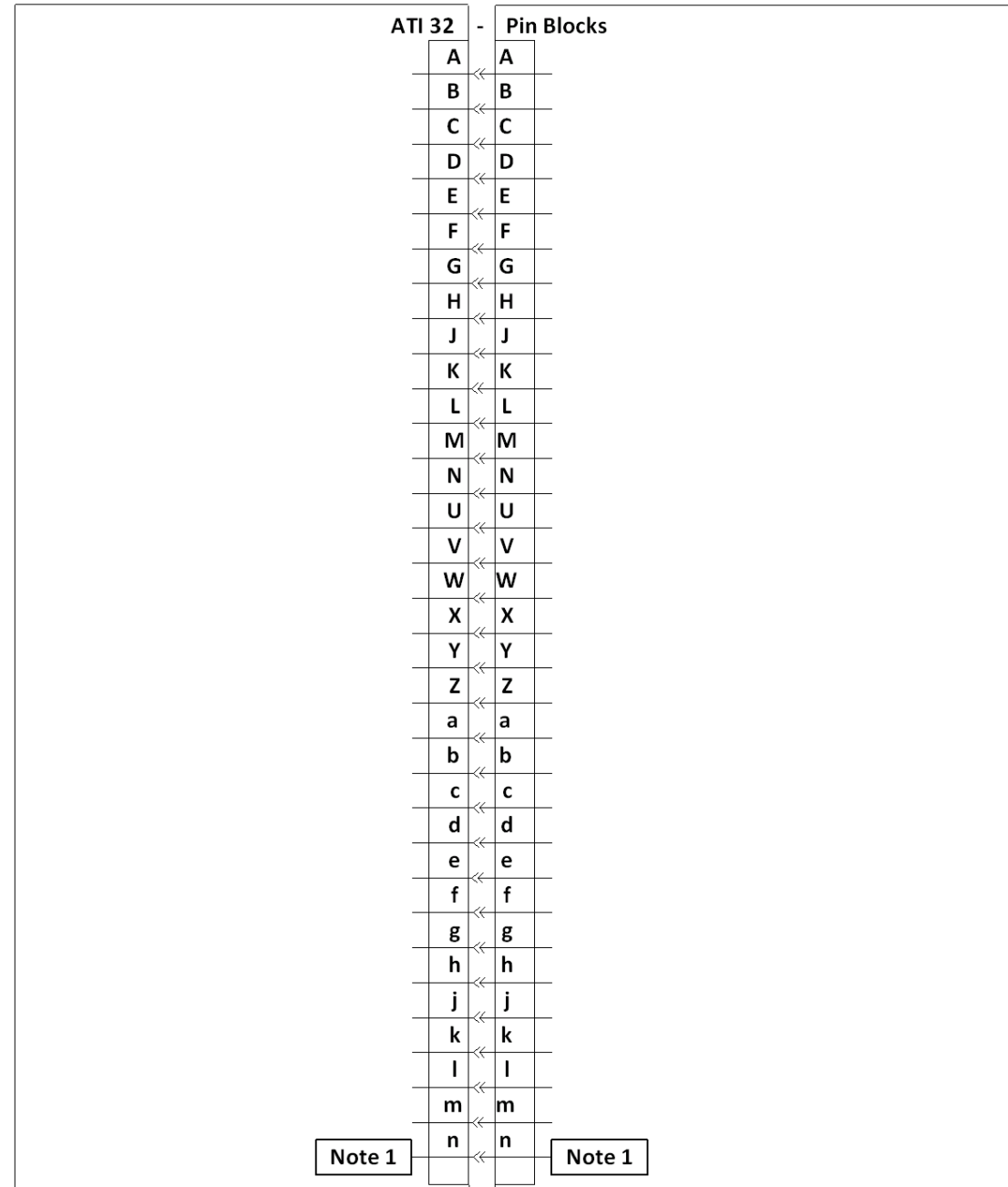

Notes:  
 1. Pin "n" of the ATI pin block is First-To-Mate and Last-To-Break contact, this pin is recommended for use as ground.

NOTES: UNLESS OTHERWISE SPECIFIED.  DO NOT SCALE DRAWING. ALL DIMENSIONS ARE IN MILLIMETERS.			1031 Goodworth Drive, Apex, NC 27539, USA Tel: +1.919.772.0115 Email: info@ati-ia.com Fax: +1.919.772.8259 www.ati-ia.com ISO 9001 Registered Company	
			PROPERTY OF ATI INDUSTRIAL AUTOMATION, INC. NOT TO BE REPRODUCED IN ANY MANNER EXCEPT ON ORDER OR WITH PRIOR WRITTEN AUTHORIZATION OF ATI.	
	DRAWN BY: A. Takla, 01/21/14	TITLE R32ZC6A Module Customer Drawing		
	CHECKED BY: W. Berrocal, 01/28/14 A. Strotzer, 01/28/14	SCALE 1:2	SIZE B	DRAWING NUMBER 9630-20-R32ZC6A
	PROJECT # 140110-1 SHEET 2 OF 2	REVISION 02		