

Rev.	Description	Initiator	Date
01	Initial Drawing	JMW	6/23/2015
02	Eco 17804; Replaced 3405-1020001-01 with updated model.	LJH	4/8/2019

P8M5 Master Module (9120-P8M5-M)

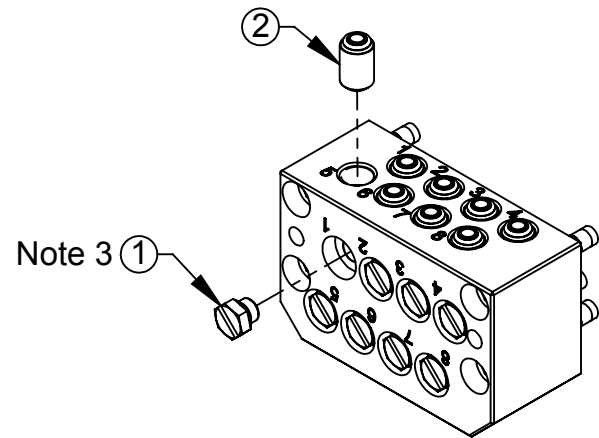

M5 Plugs in Radial Ports
(Default Configuration)
(View Rotated)

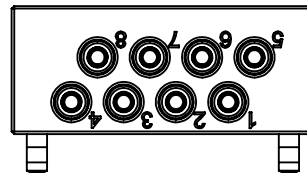
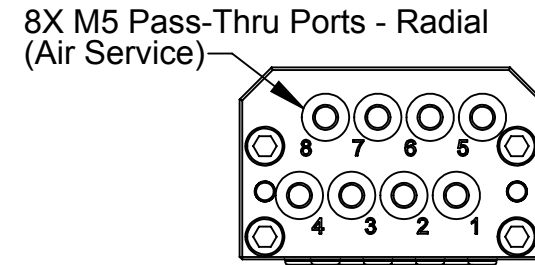
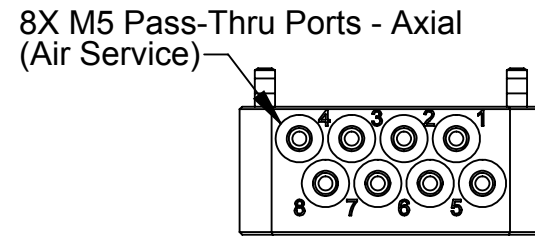
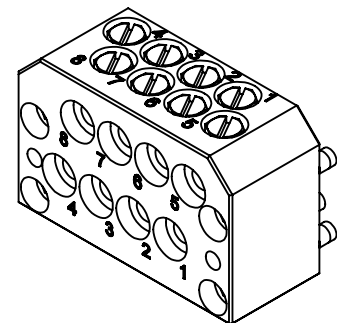

M5 Plugs in Axial Ports

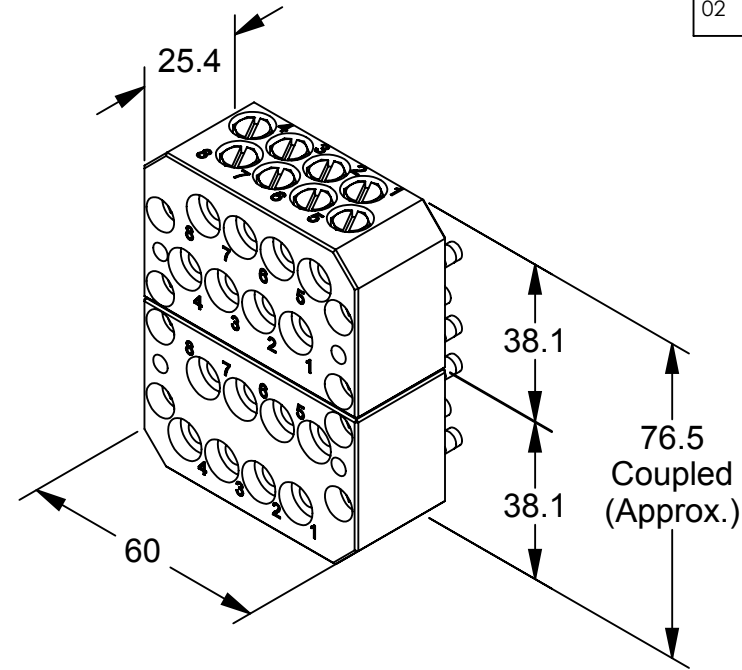

Notes:

- Material Of Construction**
- Housing - Anodized Aluminum
 - Other - Nitrile, Nylon 66

Operation

- Pneumatic Operation Only
- For optimum performance inspect mating surfaces regularly to ensure they are free of debris.
- M5 Plugs installed in Radial ports as default. Customer to move to Axial ports if desired.

P8M5 Tool Module (9120-P8M5-T)

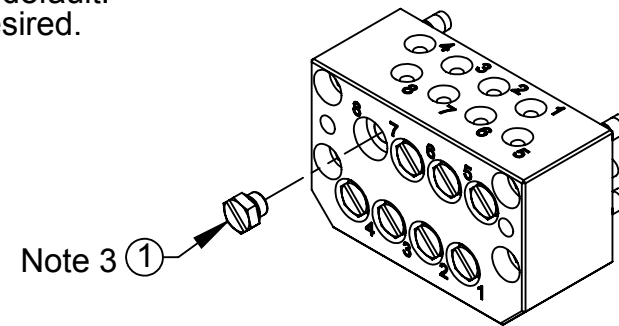
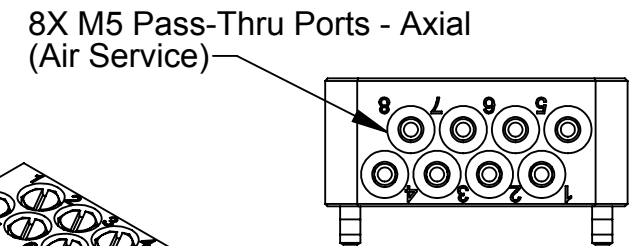
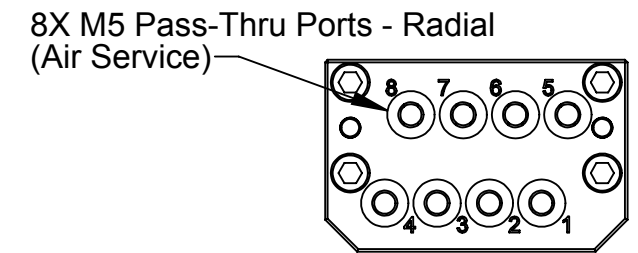
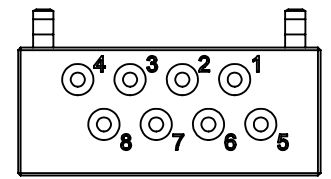

M5 Plugs in Radial Ports
(Default Configuration)

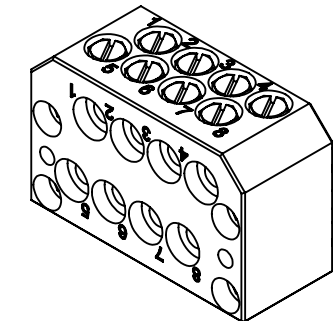

M5 Plugs in Axial Ports
(View Rotated)

P8M5-T Serviceable Parts			
ITEM NO.	QTY.	PART NUMBER	DESCRIPTION
1	8	3405-1020001-01	M5 Blanking Plug w/ gasket, SS, Nylon 66

P8M5-M Serviceable Parts			
ITEM NO.	QTY	PART NUMBER	DESCRIPTION
1	8	3405-1020001-01	M5 Blanking Plug w/ gasket, SS, Nylon 66
2	8	4010-0000014-02	M5 Rubber Bushing, Nitrile

NOTES: UNLESS OTHERWISE SPECIFIED.

DO NOT SCALE DRAWING. ALL DIMENSIONS ARE IN MILLIMETERS.



3rd ANGLE PROJECTION



1031 Goodworth Drive, Apex, NC 27539, USA
 Tel: +1.919.772.0115 Email: info@ati-ia.com
 Fax: +1.919.772.8259 www.ati-ia.com
 ISO 9001 Registered Company

PROPERTY OF ATI INDUSTRIAL AUTOMATION, INC. NOT TO BE REPRODUCED IN ANY MANNER EXCEPT ON ORDER OR WITH PRIOR WRITTEN AUTHORIZATION OF ATI.

DRAWN BY: J. Winterroth, 6/23/15		TITLE	
CHECKED BY: D. Norton, 6/25/15		P8M5 Module Drawing	
PROJECT # 150309-1	SHEET 1 OF 1	SCALE 2:3	SIZE B
		DRAWING NUMBER 9630-20-P8M5	REVISION 02