

Rev.	Description	Initiator	Date
03P	Changed Wiring for Mfg.	RMH	3/13/2014
04	Release	RMH	3/18/2014

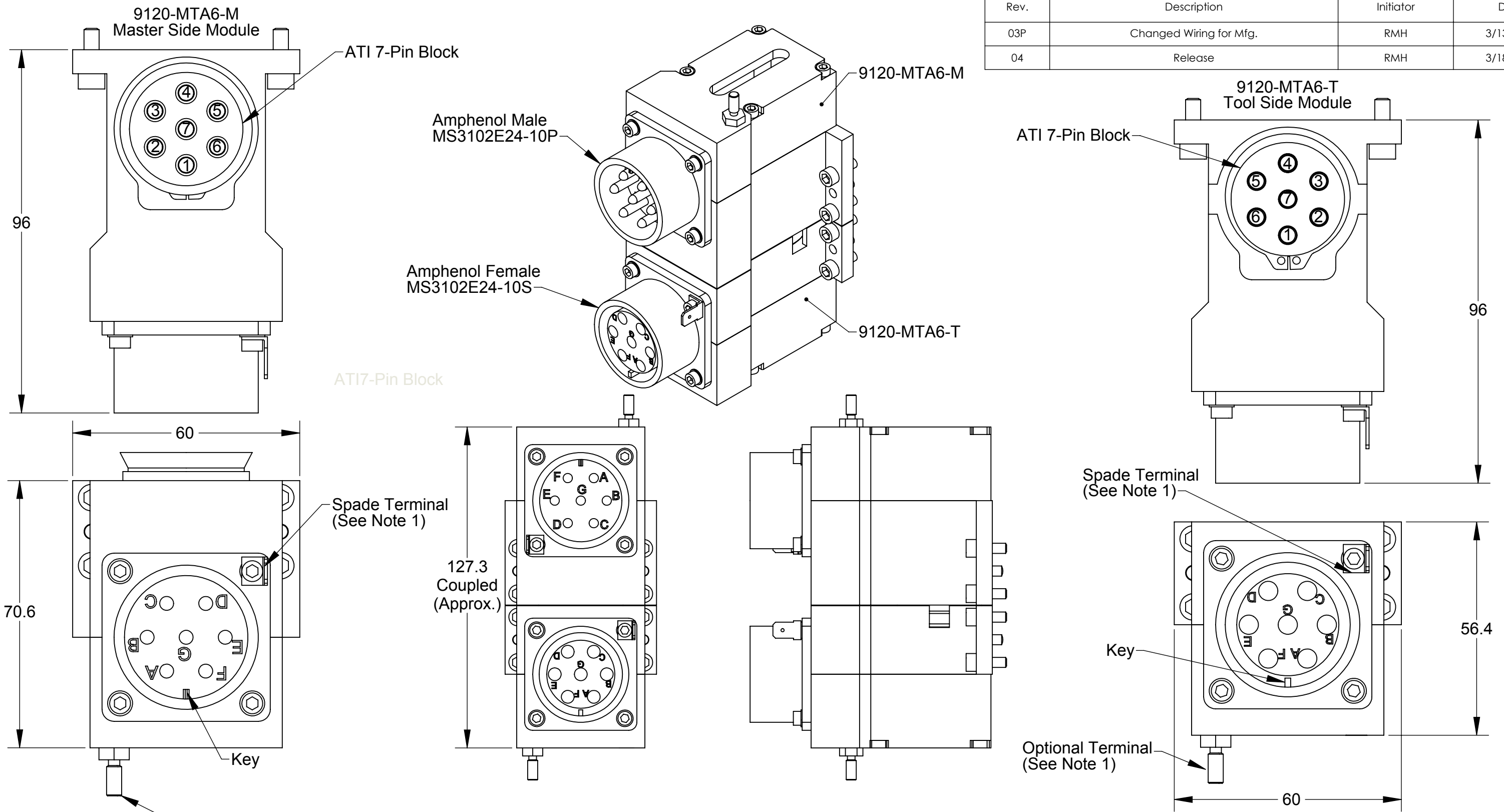

- Notes:**
- Spade terminal connection is First-to-mate Last-to-break at the Tool Changer interface. Spade terminals provided for passing PE from master module to tool module.
 - DANGER!** - For electrical modules using > 60 VDC or 42 VAC, NO contact should be attempted before removing power. This especially includes separation or insertion of the mating connectors or any contact with the tool changer or its' components.

NOTES: UNLESS OTHERWISE SPECIFIED.
DO NOT SCALE DRAWING. ALL DIMENSIONS ARE IN MILLIMETERS.

ATI INDUSTRIAL AUTOMATION

1031 Goodworth Drive, Apex, NC 27539, USA
Tel: +1.919.772.0115 Email: info@ati-ia.com
Fax: +1.919.772.8259 www.ati-ia.com
ISO 9001 Registered Company

PROPERTY OF ATI INDUSTRIAL AUTOMATION, INC. NOT TO BE REPRODUCED IN ANY MANNER EXCEPT ON ORDER OR WITH PRIOR WRITTEN AUTHORIZATION OF ATI.

DRAWN BY: A Pongor 3/7/13	TITLE
CHECKED BY: P Luczka 3/11/13 B Henderson 3/12/2013	MTA6 Module Drawing
PROJECT # 120807-1 SHEET 1 OF 2	SCALE 1:2
	SIZE B
	DRAWING NUMBER 9630-20-MTA6
	REVISION 04

3rd ANGLE PROJECTION

Rev.	Description	Initiator	Date
-	See Sheet1	-	-

ATI 7-Pin Block

9120-MTA6-M

9120-MTA6-T

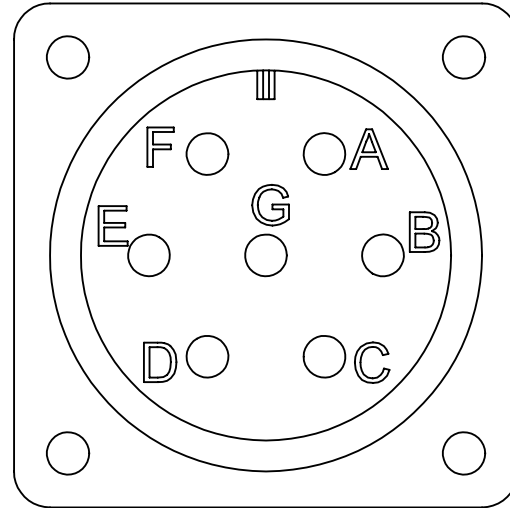

Amphenol Male
MS3102E24-10P

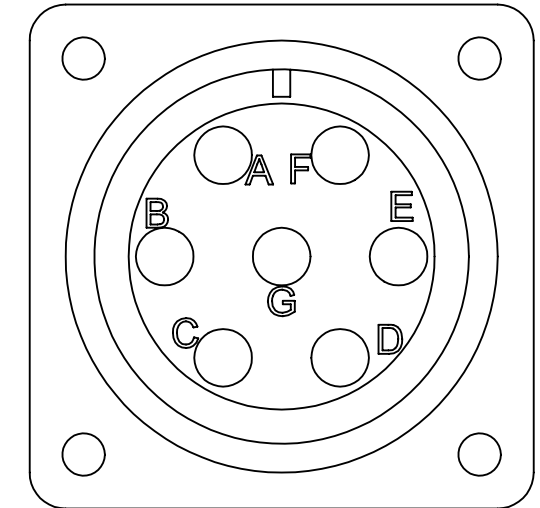
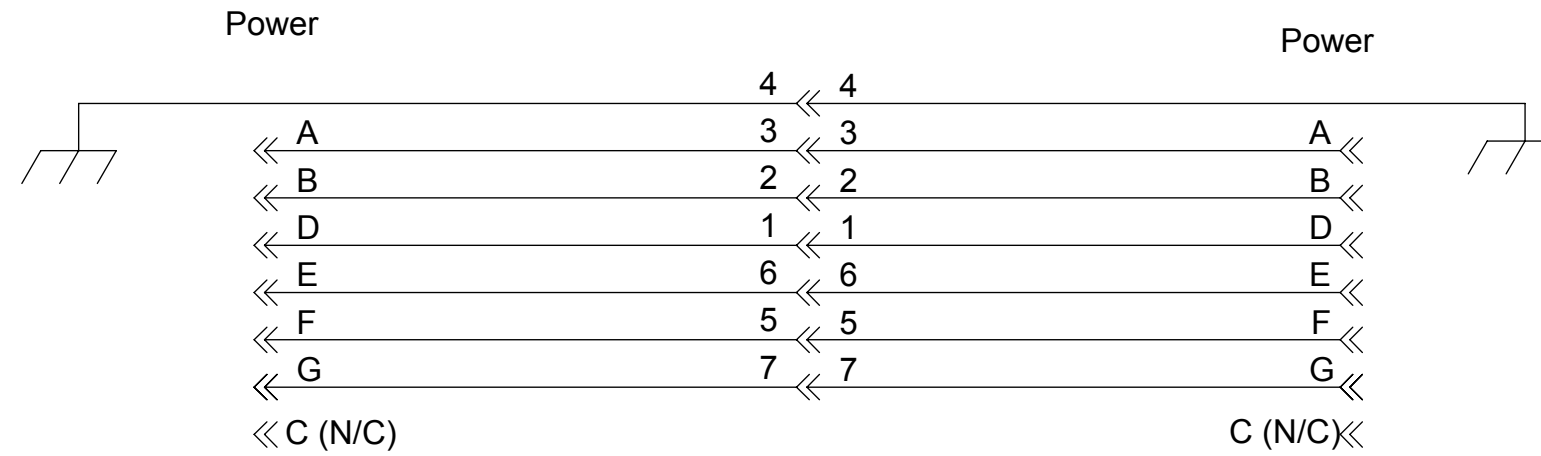

Amphenol Female
MS3102E24-10S

Note:
1. Pin 4 on 7 -pin block is to first-to-mate , last-to-break.

NOTES: UNLESS OTHERWISE SPECIFIED.

DO NOT SCALE DRAWING. ALL DIMENSIONS ARE IN MILLIMETERS.



3rd ANGLE PROJECTION



1031 Goodworth Drive, Apex, NC 27539, USA
Tel: +1.919.772.0115 Email: info@ati-ia.com
Fax: +1.919.772.8259 www.ati-ia.com
ISO 9001 Registered Company

PROPERTY OF ATI INDUSTRIAL AUTOMATION, INC. NOT TO BE REPRODUCED IN ANY MANNER EXCEPT ON ORDER OR WITH PRIOR WRITTEN AUTHORIZATION OF ATI.

DRAWN BY: A Pongor 3/7/13		TITLE	
CHECKED BY: P Luczka 3/11/13 B Henderson 3/12/2013		MTA6 Module Drawing	
PROJECT #	120807-1	SHEET	OF 2
SCALE	1:2	SIZE	B
DRAWING NUMBER	9630-20-MTA6		REVISION
			04