

REV.	DESCRIPTION	INITIATOR	DATE
08	ECO 19733; page 4 note 1 now reads 1A / 30VDC	EPR	2/12/2021
09	Eco 19860; Updated Potting Opening.	CF	4/14/2021

**9120-ML8A-M
Master Module**

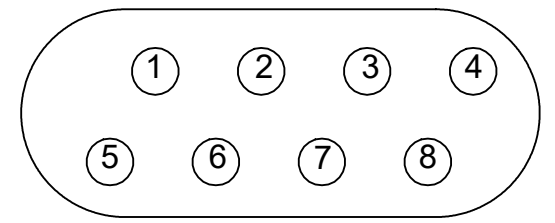
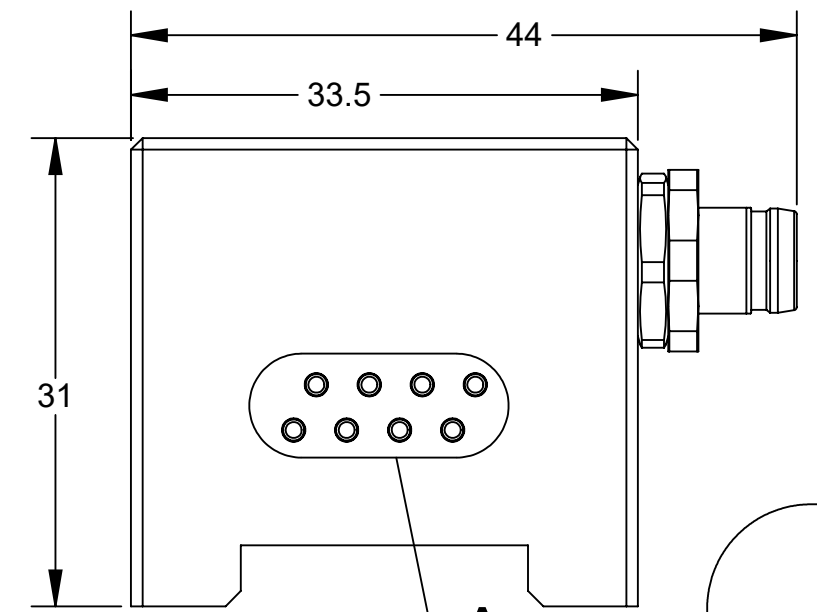
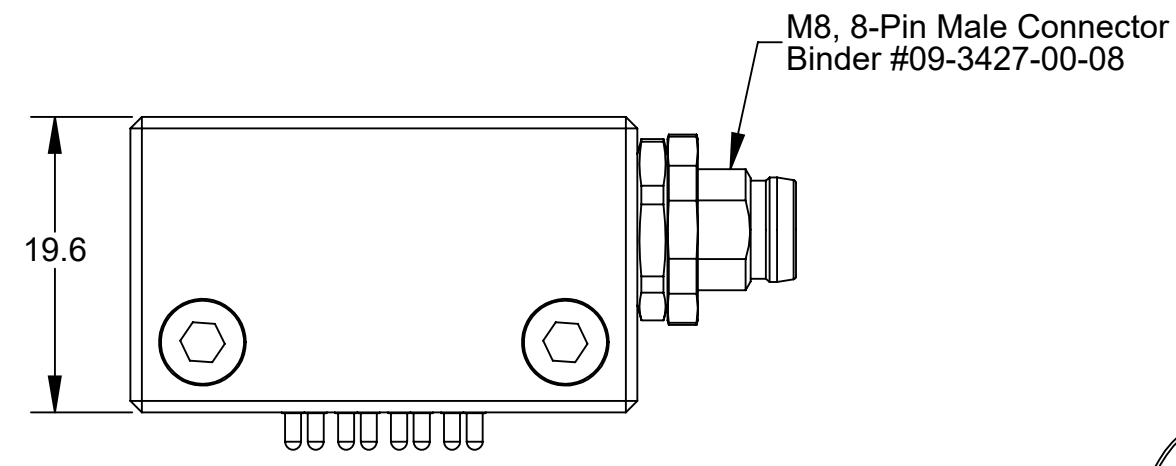

DETAIL A
SCALE 4 : 1

See Note 2

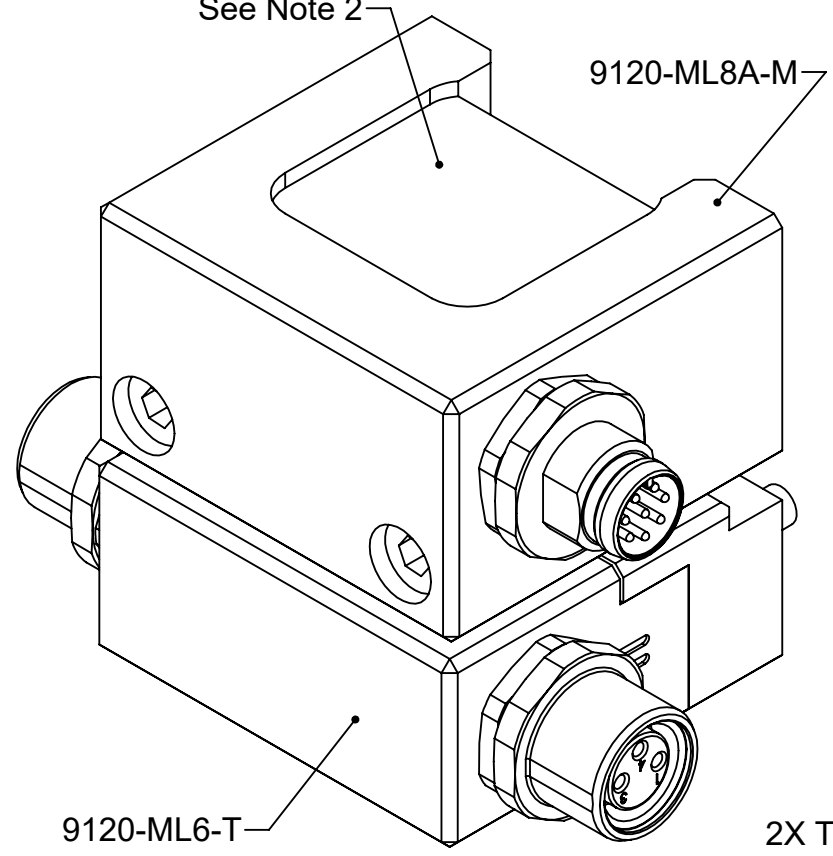

**9120-ML6-T
Tool Module**

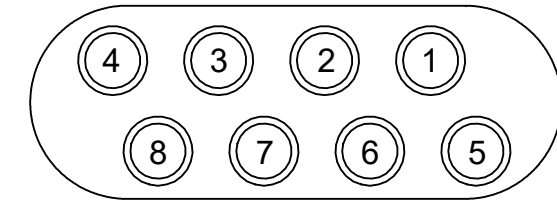
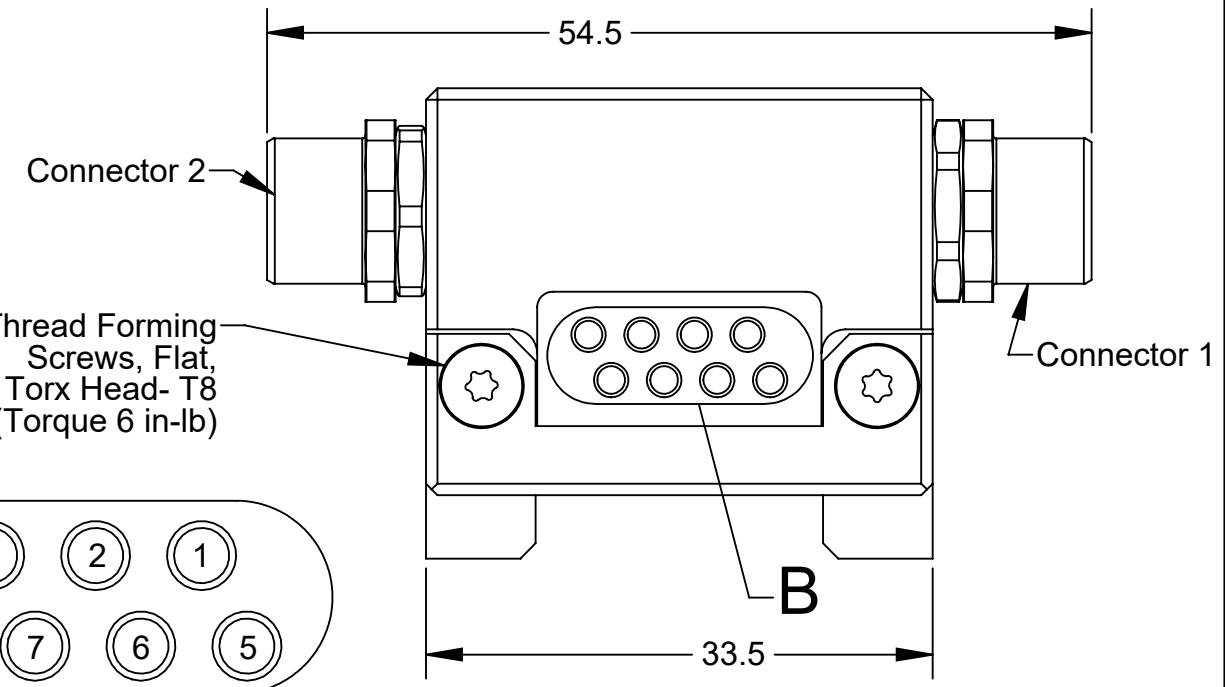
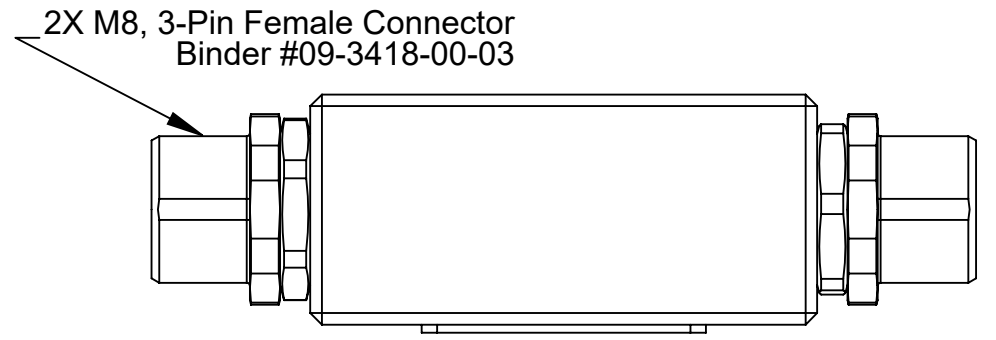

DETAIL B
SCALE 4 : 1

- Notes:
1. See Sheet 3 for detailed Electrical Schematic and Electrical rating.
 2. Both modules are potted with 3M DP270 potting material.

NOTES: UNLESS OTHERWISE SPECIFIED.

DO NOT SCALE DRAWING. ALL DIMENSIONS ARE IN MILLIMETERS.

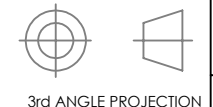

1031 Goodworth Drive, Apex, NC 27539, USA
 Tel: +1.919.772.0115 www.ati-ia.com
 Fax: +1.919.772.8259 ISO 9001 Registered Company

PROPERTY OF ATI INDUSTRIAL AUTOMATION, INC. NOT TO BE REPRODUCED IN ANY MANNER EXCEPT ON ORDER OR WITH PRIOR WRITTEN AUTHORIZATION OF ATI.

DRAWN BY: B. Smith, 6/06/19		TITLE	
CHECKED BY: W.Berrocal, 12/2/2019		ML8AM ML6T Potted Module Customer Drawing	
PROJECT # 181129-2	SHEET 1 OF 4	SCALE 2:1	SIZE B
		DRAWING NUMBER	REVISION
		9630-20-ML8AM ML6T	09

**9120-ML8A-M
Master Module**

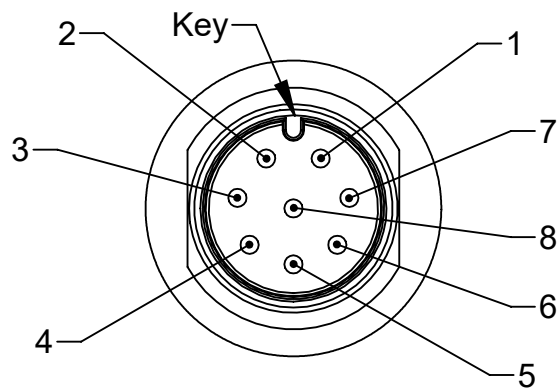
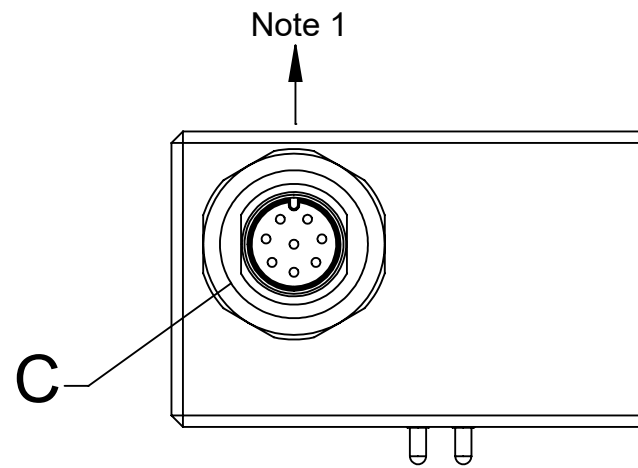

DETAIL C
Master 8-Pin
Male Connector
SCALE 4 : 1

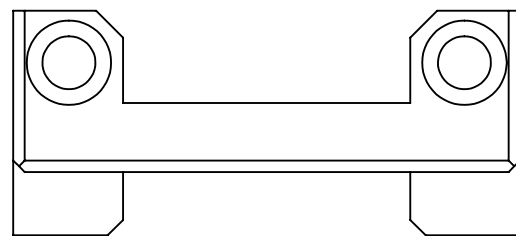
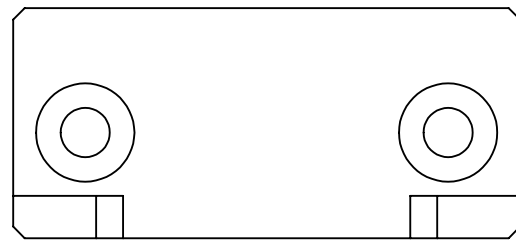

Serviceable part 3700-20-11153 Adapter Plate
common on all Tool modules.

**9120-ML6-T
Tool Module**

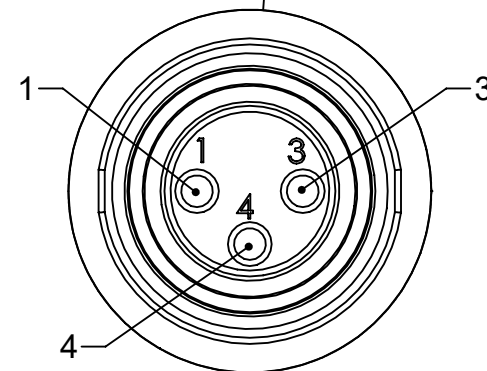
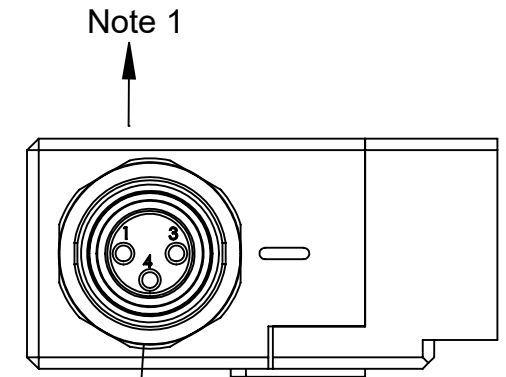
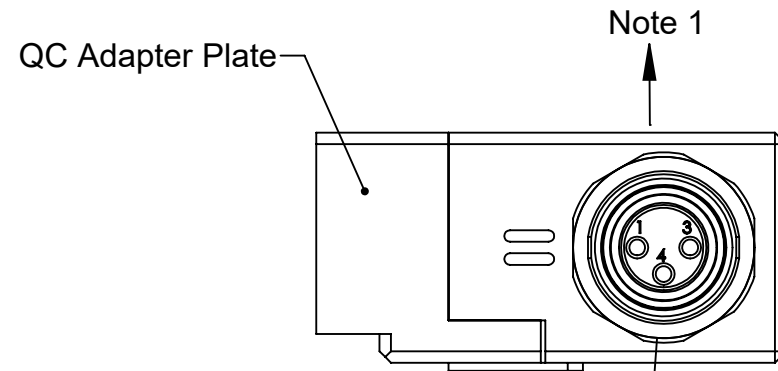

DETAIL D
3-POLE FEMALE CONNECTOR
SCALE 4 : 1

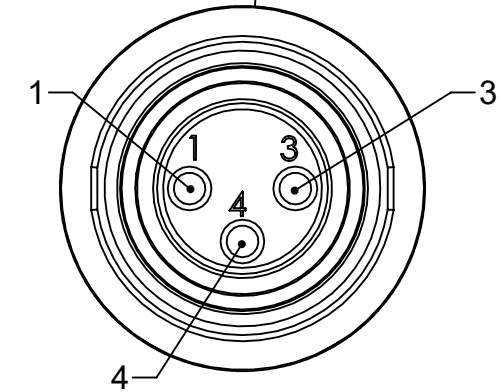

DETAIL E
3-POLE FEMALE CONNECTOR
SCALE 4 : 1

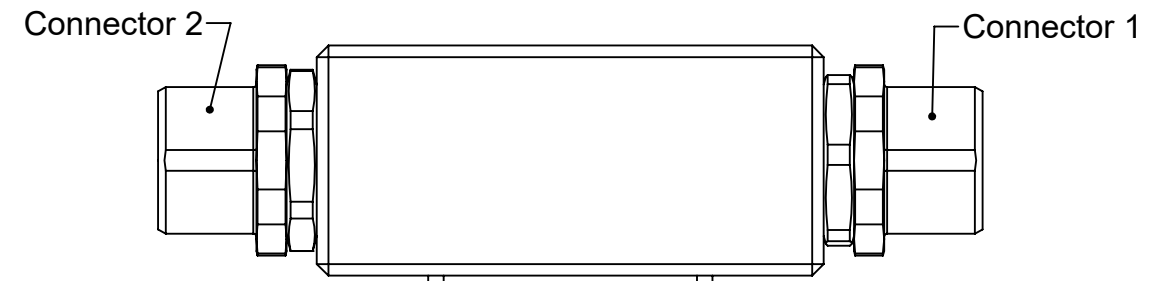

Notes:
1. Mating right angle cordset direction.

NOTES: UNLESS OTHERWISE SPECIFIED.

DO NOT SCALE DRAWING.
ALL DIMENSIONS ARE IN
MILLIMETERS.

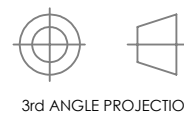

1031 Goodworth Drive, Apex, NC 27539, USA
Tel: +1.919.772.0115 www.ati-ia.com
Fax: +1.919.772.8259 ISO 9001 Registered Company

PROPERTY OF ATI INDUSTRIAL AUTOMATION, INC. NOT TO BE REPRODUCED IN ANY MANNER EXCEPT ON ORDER OR WITH PRIOR WRITTEN AUTHORIZATION OF ATI.

DRAWN BY: B. Smith, 6/06/19		TITLE		
CHECKED BY: W.Berrocal, 12/2/2019		ML8AM ML6T Potted Module Customer Drawing		
PROJECT # 181129-2	SHEET 2 OF 4	SCALE	SIZE	DRAWING NUMBER
		2:1	B	9630-20-ML8AM ML6T
				REVISION
				09

Mounting Hardware

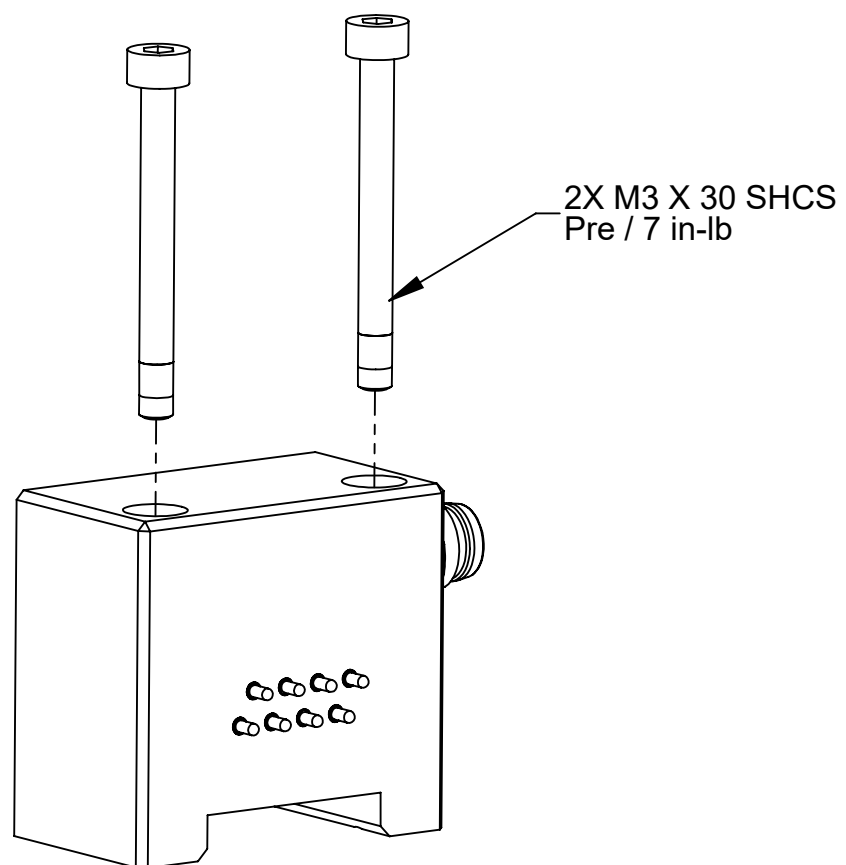

**9120-ML8A-M
Master Module**

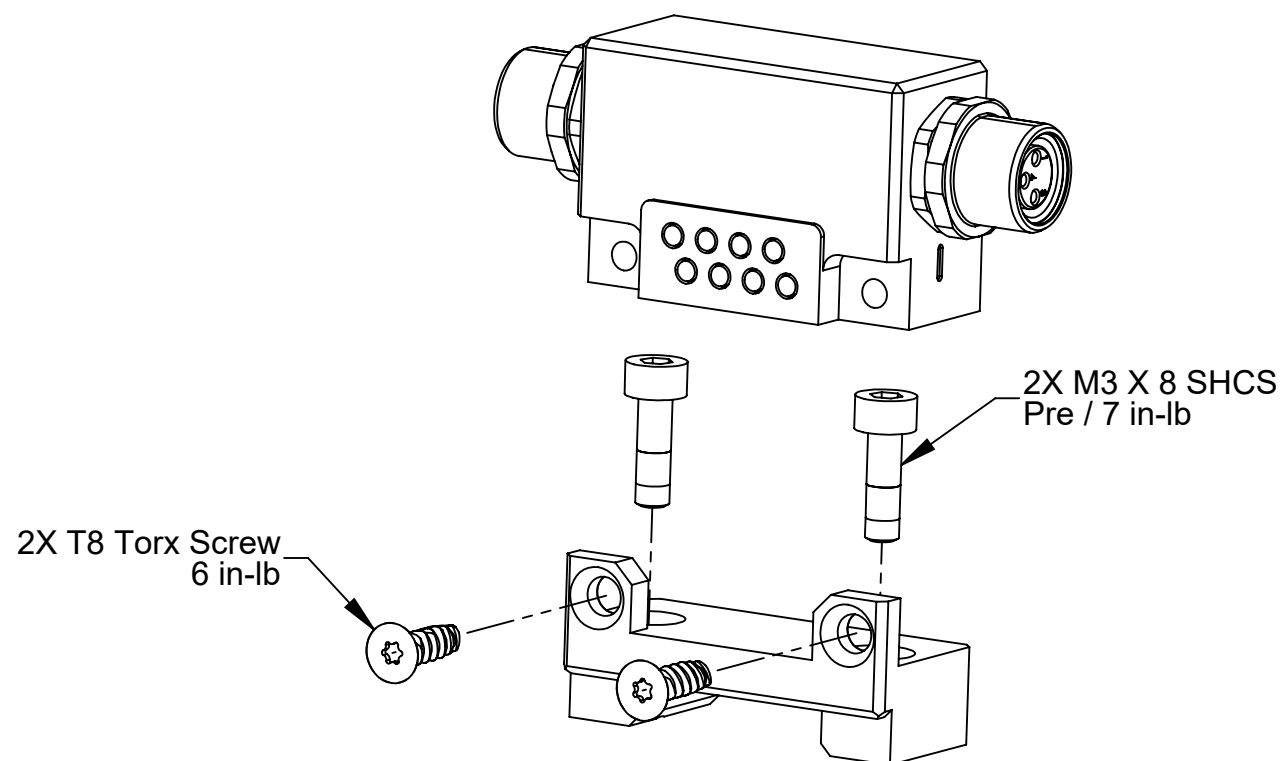

**9120-ML6-T
Tool Module**

NOTES: UNLESS OTHERWISE SPECIFIED.

DO NOT SCALE DRAWING.
ALL DIMENSIONS ARE IN
MILLIMETERS.



3rd ANGLE PROJECTION

1031 Goodworth Drive, Apex, NC 27539, USA
Tel: +1.919.772.0115 www.ati-ia.com
Fax: +1.919.772.8259 ISO 9001 Registered Company

PROPERTY OF ATI INDUSTRIAL AUTOMATION, INC. NOT TO BE REPRODUCED IN ANY MANNER EXCEPT ON ORDER OR WITH PRIOR WRITTEN AUTHORIZATION OF ATI.

DRAWN BY: B. Smith, 6/06/19		TITLE		
CHECKED BY: W.Berrocal, 12/2/2019		ML8AM ML6T Potted Module Customer Drawing		
PROJECT # 181129-2	SHEET 3 OF 4	SCALE	SIZE	DRAWING NUMBER
		3:2	B	9630-20-ML8AM ML6T
				REVISION
				09

9120-ML8A-M

9120-ML6-T

M8, 8-Pin
Male Connector

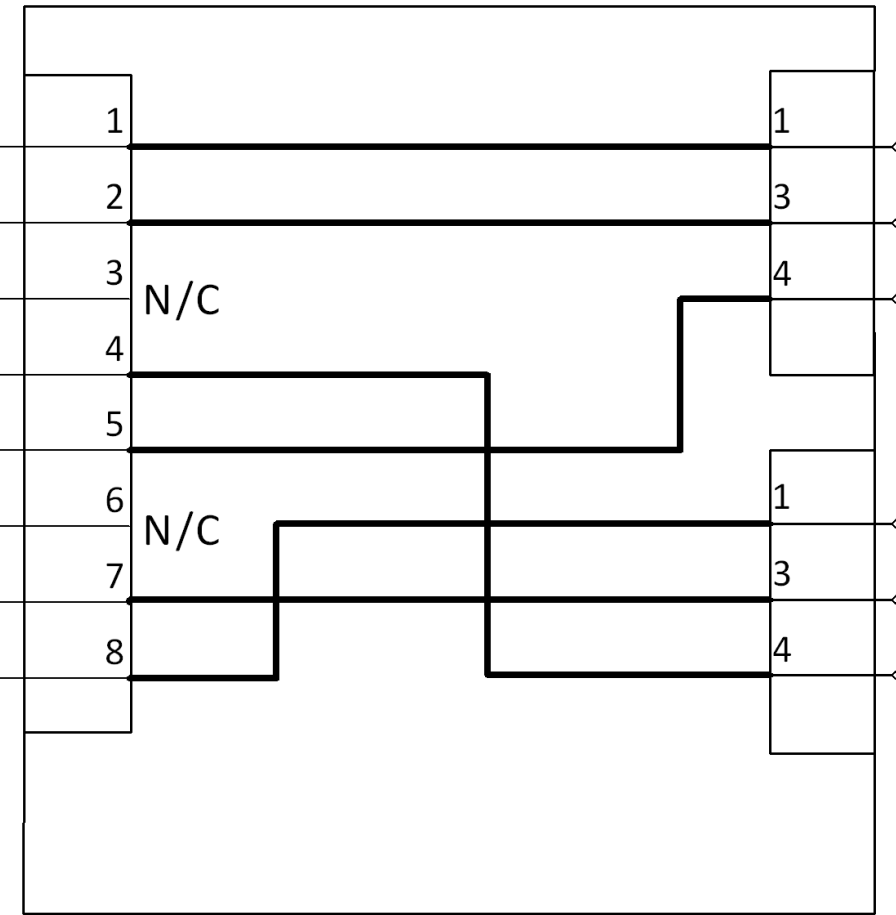
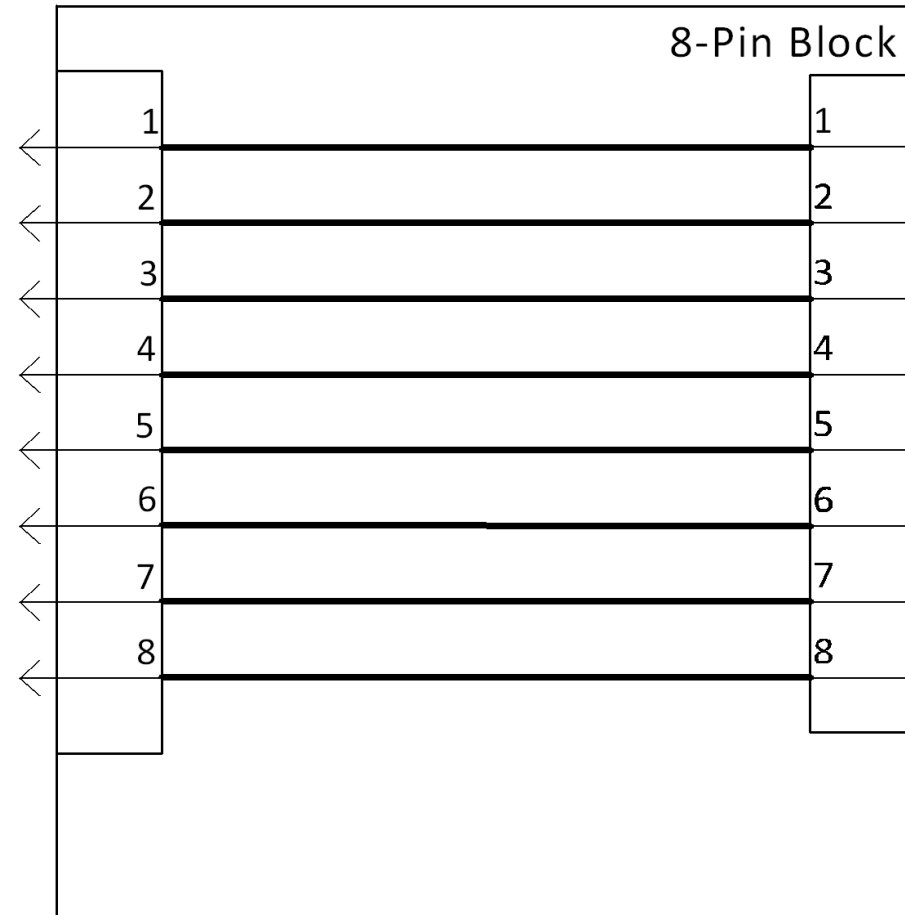

M8, 3-Pin
Female
Connector 1

M8, 3-Pin
Female
Connector 2

Notes:
1. Electrical Rating: 1A / 30 VDC

NOTES: UNLESS OTHERWISE SPECIFIED.

DO NOT SCALE DRAWING.
ALL DIMENSIONS ARE IN
MILLIMETERS.



3rd ANGLE PROJECTION

1031 Goodworth Drive, Apex, NC 27539, USA
Tel: +1.919.772.0115 Email: info@ati-ia.com
Fax: +1.919.772.8259 www.ati-ia.com
ISO 9001 Registered Company

PROPERTY OF ATI INDUSTRIAL AUTOMATION, INC. NOT TO BE REPRODUCED IN ANY MANNER EXCEPT ON ORDER OR WITH PRIOR WRITTEN AUTHORIZATION OF ATI.

DRAWN BY: B. Smith, 6/06/19		TITLE	
CHECKED BY: W.Berrocal, 12/2/2019		ML8AM ML6T Potted Module Customer Drawing	
PROJECT #	181129-2	SHEET	4 OF 4
SCALE	2:1	SIZE	B
DRAWING NUMBER	9630-20-ML8AM ML6T		REVISION
			09