

| Rev. | Description | Initiator | Date |
|------|---------------------------|-----------|-----------|
| 02 | Eco 9568; Created Drawing | CF | 4/11/2012 |

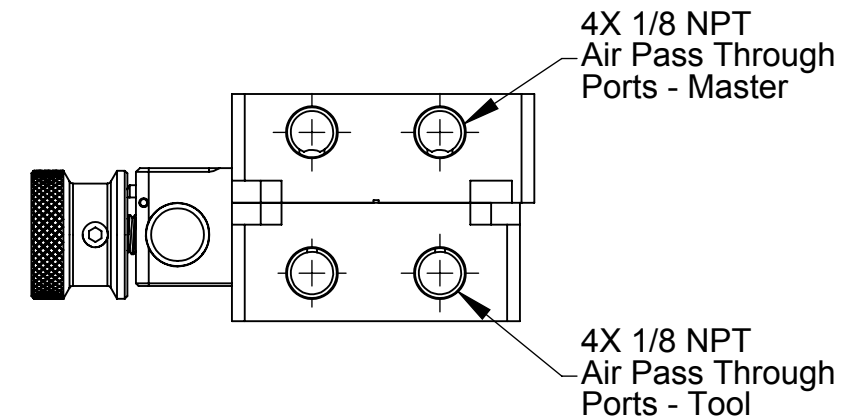
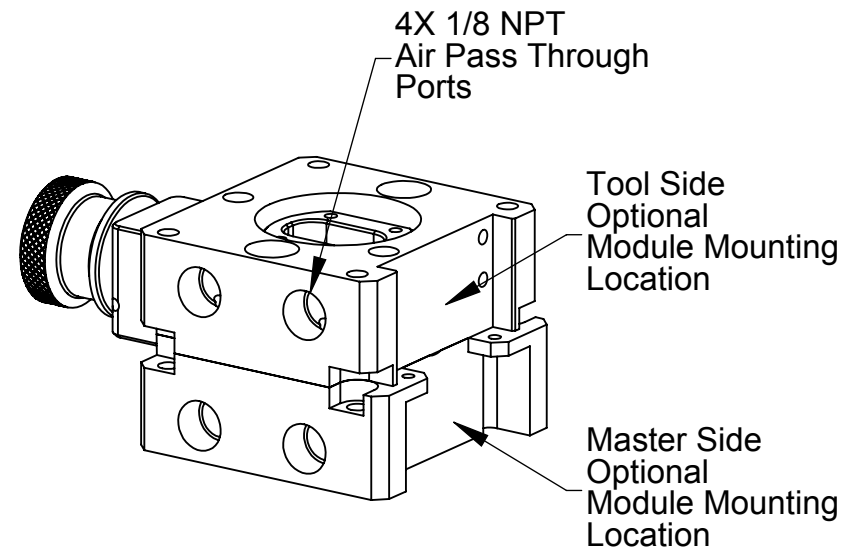
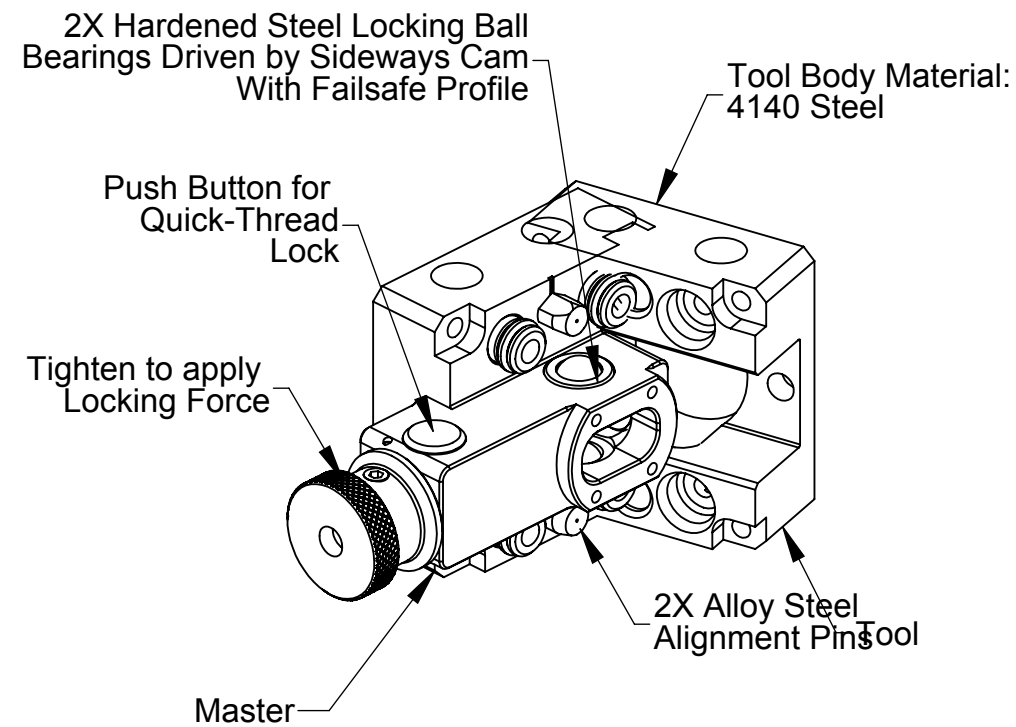
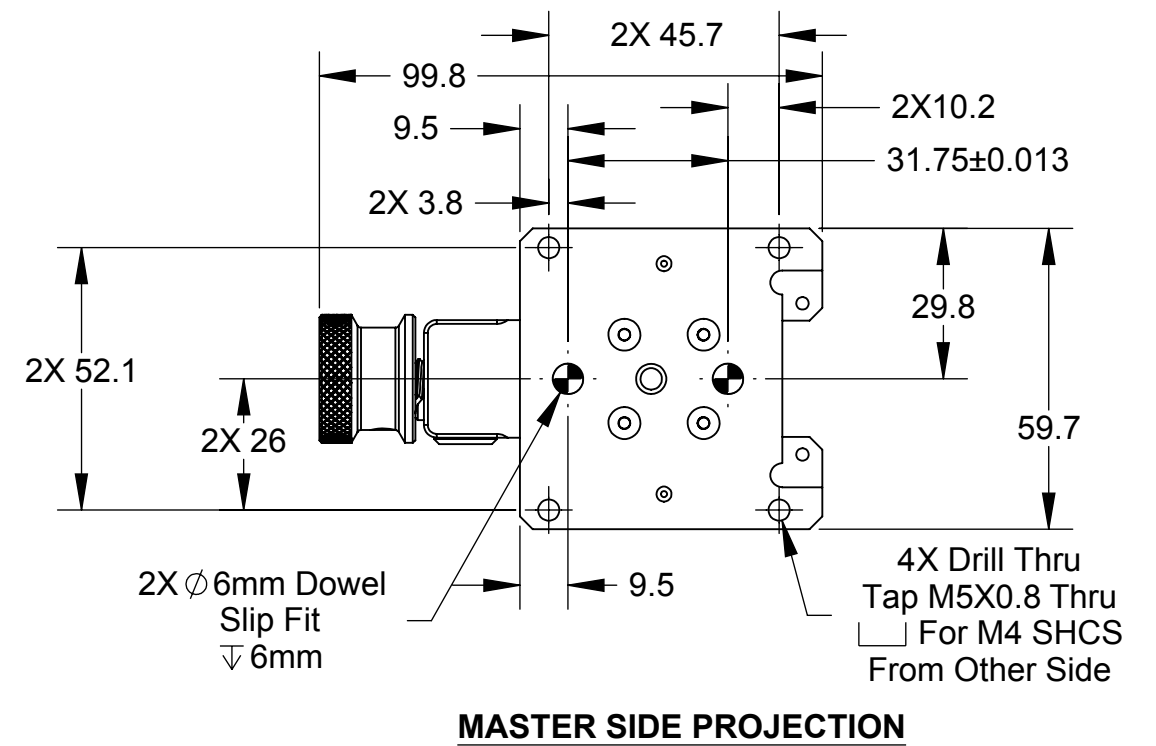
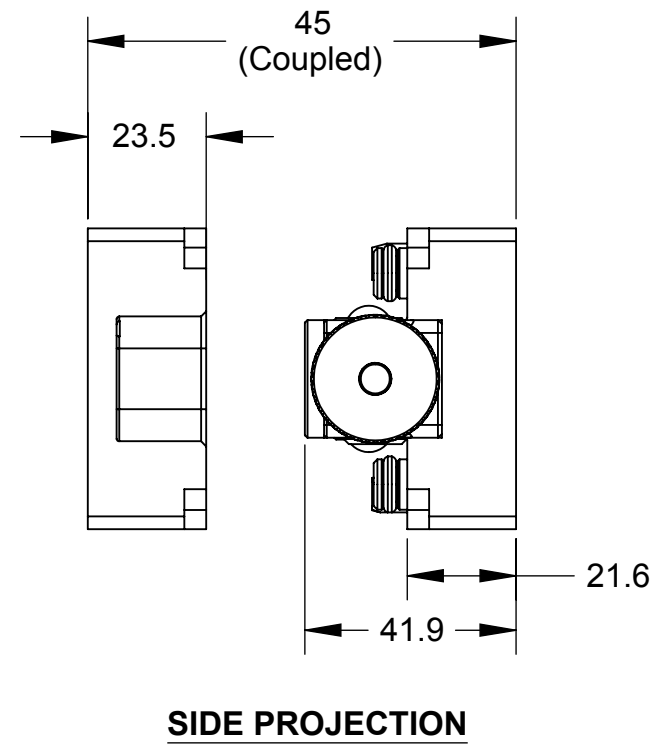
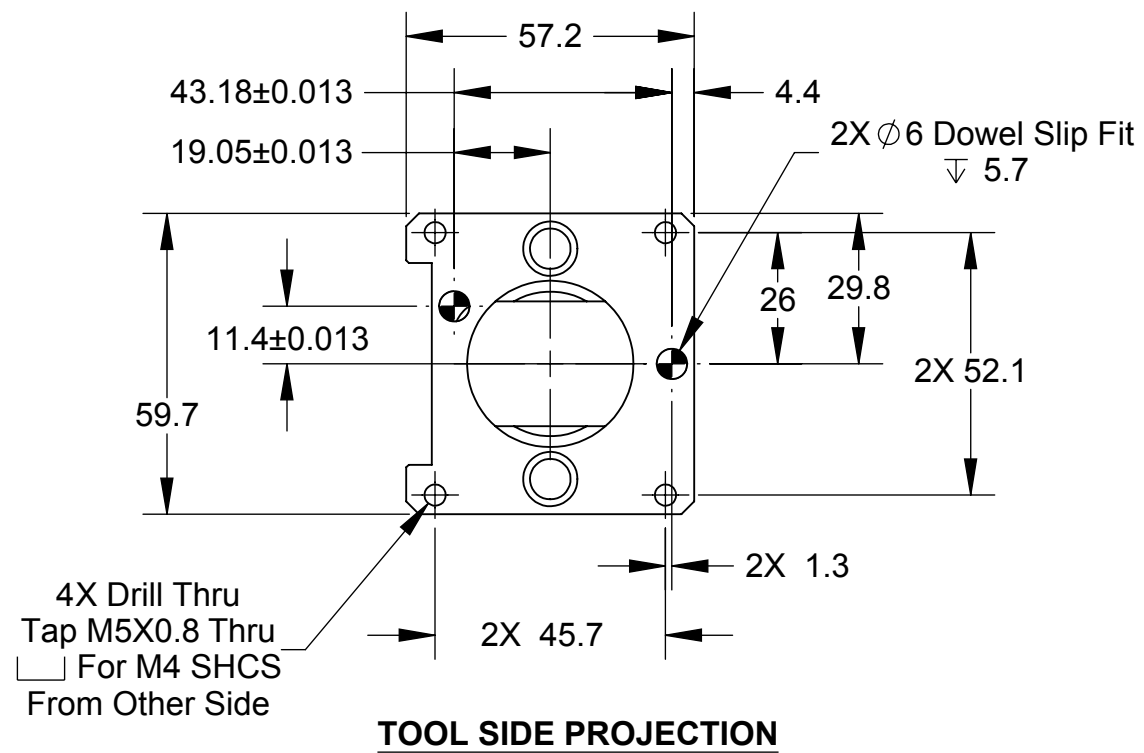

Notes:

1. Suggested Payload Limit: 35 lbs
Pneumatic Pass Through: (4) 1/8" NPT
2. Unit Features one additional module mounting flat
3. Compatible Modules: D series and K series electrical modules

NOTES: UNLESS OTHERWISE SPECIFIED.

DO NOT SCALE DRAWING. ALL DIMENSIONS ARE IN MILLIMETERS.

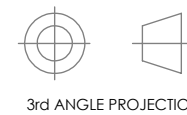

1031 Goodworth Drive, Apex, NC 27539, USA
Tel: +1.919.772.0115 Email: info@ati-ia.com
Fax: +1.919.772.8259 www.ati-ia.com
ISO 9001 Registered Company

PROPERTY OF ATI INDUSTRIAL AUTOMATION, INC. NOT TO BE REPRODUCED IN ANY MANNER EXCEPT ON ORDER OR WITH PRIOR WRITTEN AUTHORIZATION OF ATI.

| | | | |
|---|--------------|---|-------------|
| DRAWN BY: C. Flesock, 4/11/12 | | TITLE | |
| CHECKED BY: D. Wagner/D.Norton 4/11/12 | | Manual Coupler with Quick Action Screw Lock Drawing | |
| PROJECT # 070724-1 | SHEET 1 OF 2 | SCALE 1:1.5 | SIZE B |
| | | DRAWING NUMBER 9630-20-MC16 | REVISION 02 |

| Rev. | Description | Initiator | Date |
|------|-------------|-----------|------|
| - | See Sheet1 | - | - |

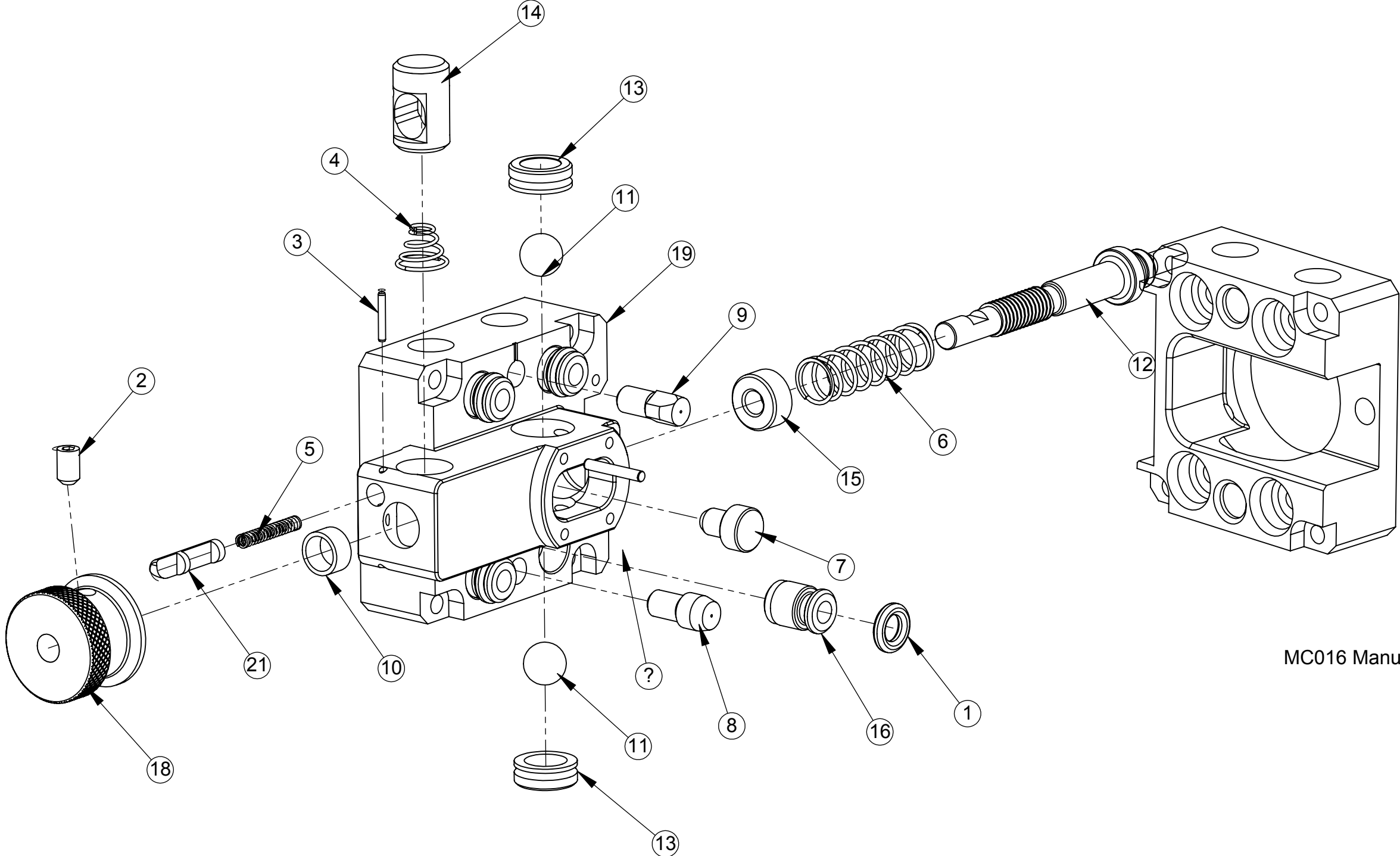



9122-016T-000
MC016 Manual Coupler Base Tool with (4) 1/8" NPT Ports

9122-016M-000
MC016 Manual Coupler Base Master with (4) 1/8" NPT Ports

NOTES: UNLESS OTHERWISE SPECIFIED.

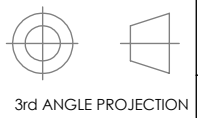
DO NOT SCALE DRAWING. ALL DIMENSIONS ARE IN MILLIMETERS.



| | | | | |
|---|--------------|--|--------------------------------|----------------|
|  | | 1031 Goodworth Drive, Apex, NC 27539, USA Tel: +1.919.772.0115 Email: info@ati-ia.com Fax: +1.919.772.8259 www.ati-ia.com ISO 9001 Registered Company | | |
| | | PROPERTY OF ATI INDUSTRIAL AUTOMATION, INC. NOT TO BE REPRODUCED IN ANY MANNER EXCEPT ON ORDER OR WITH PRIOR WRITTEN AUTHORIZATION OF ATI. | | |
| DRAWN BY: C. Flesock, 4/11/12 CHECKED BY: D. Wagner/D.Norton 4/11/12 | | TITLE Manual Coupler with Quick Action Screw Lock Drawing | | |
| PROJECT # 070724-1 SHEET 2 OF 2 | SCALE 1:1 | SIZE B | DRAWING NUMBER 9630-20-MC16 | REVISION 02 |