

Rev.	Description	Initiator	Date
01P	Initial design.	WB	8/31/2015
02	No changes. Release.	WB	4/19/2016

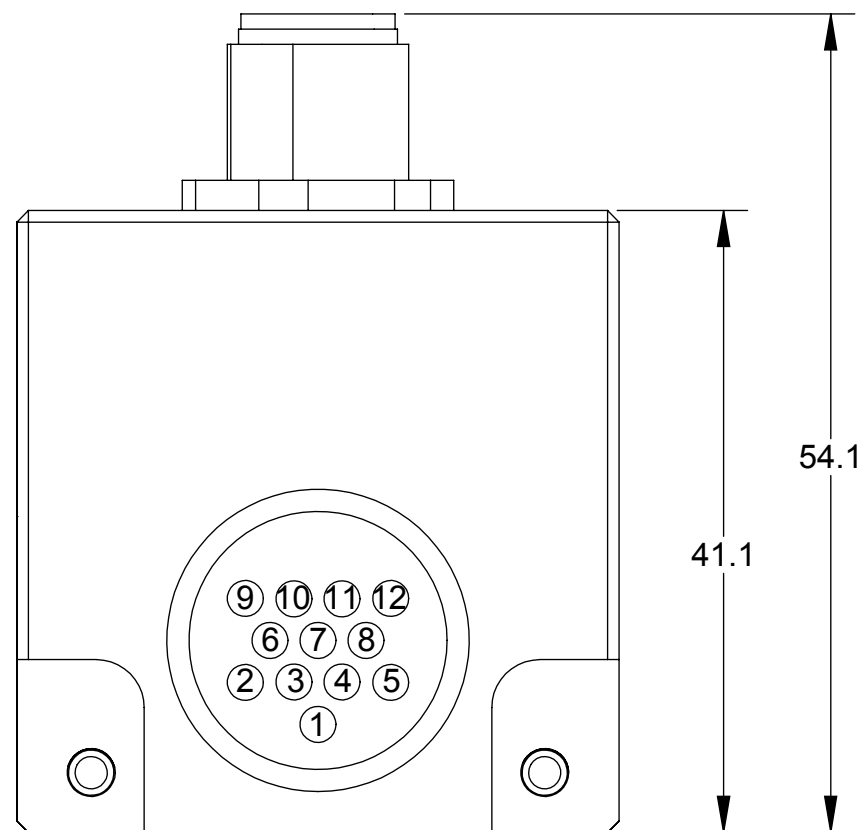

ELECTRICAL SCHEMATIC

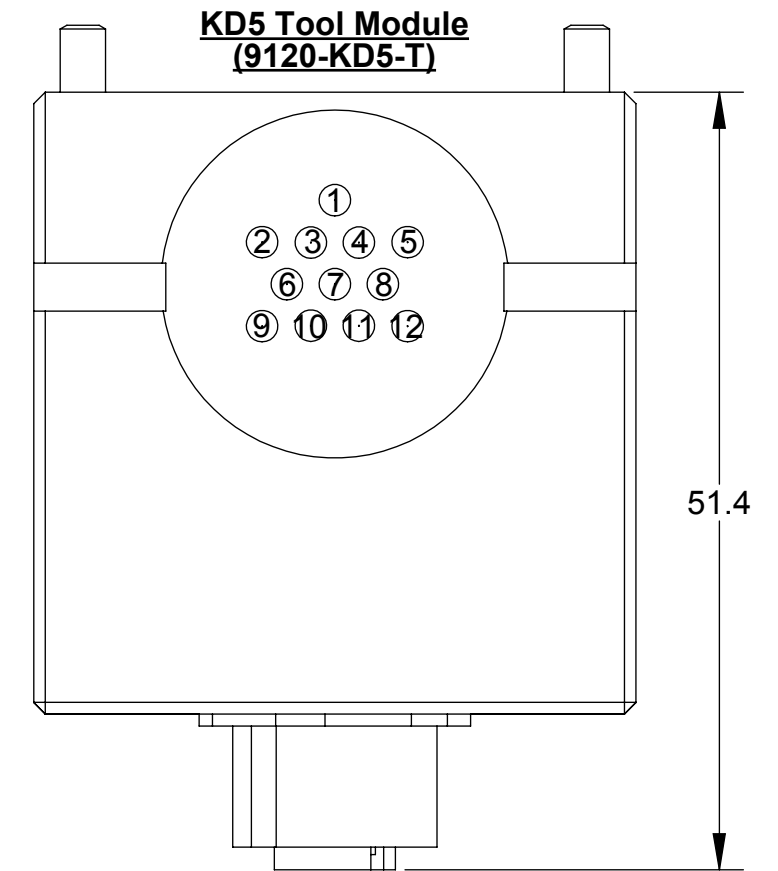
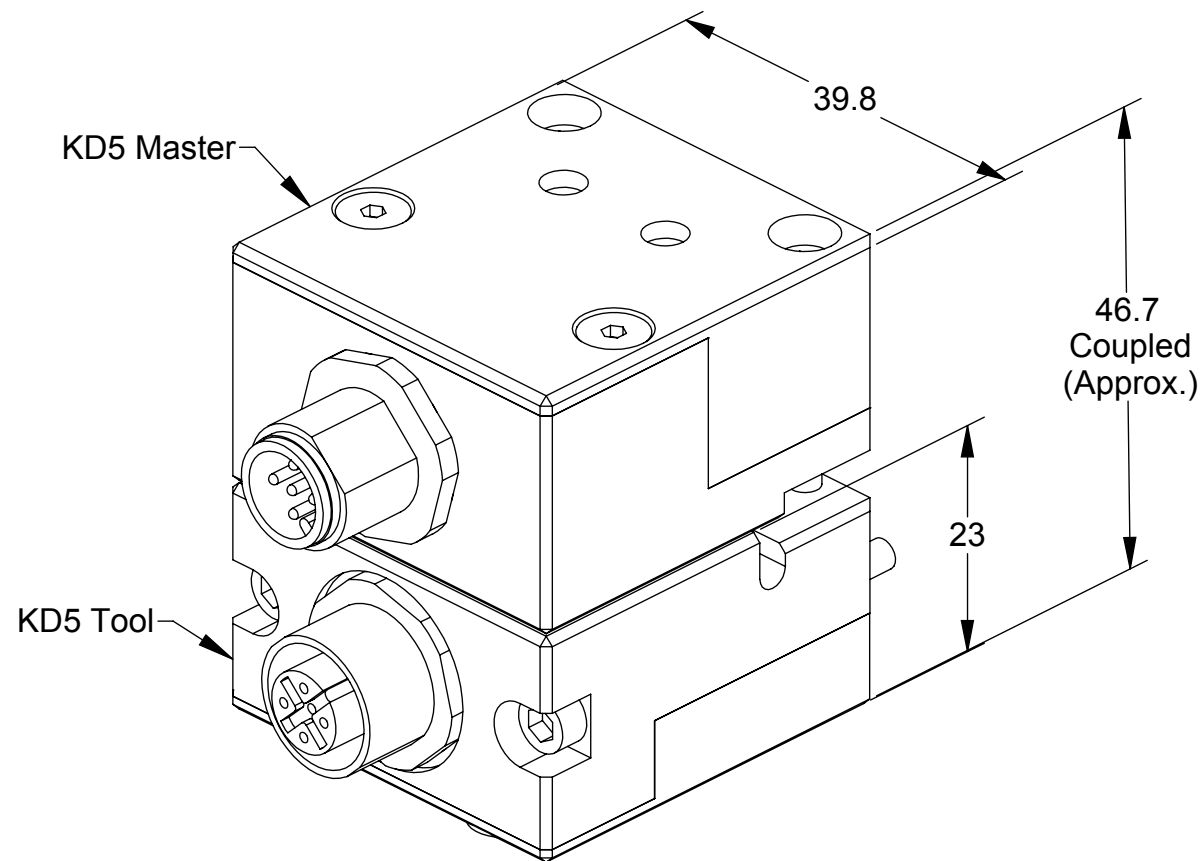
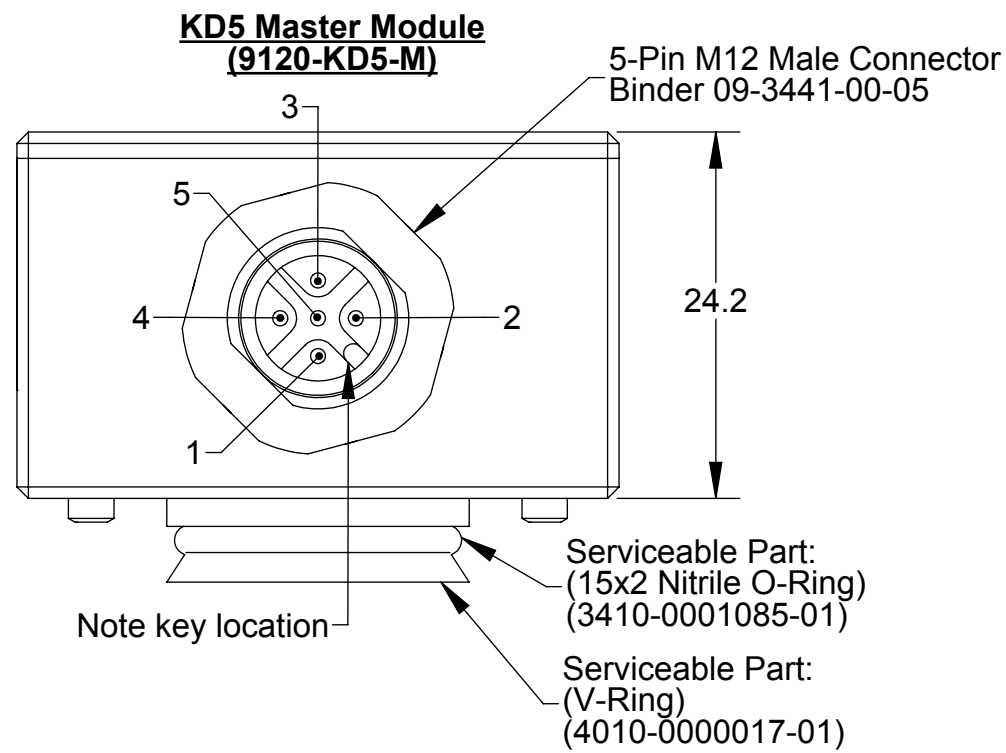
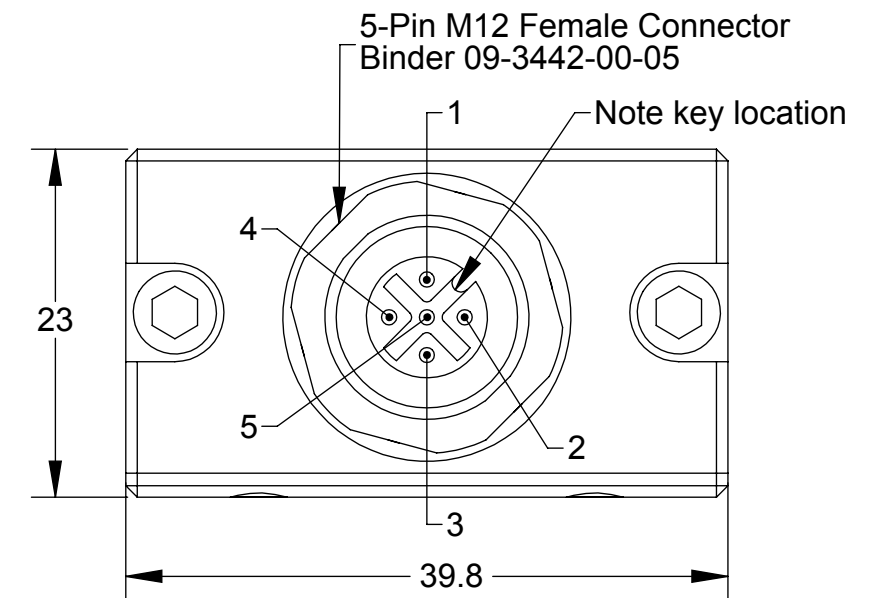
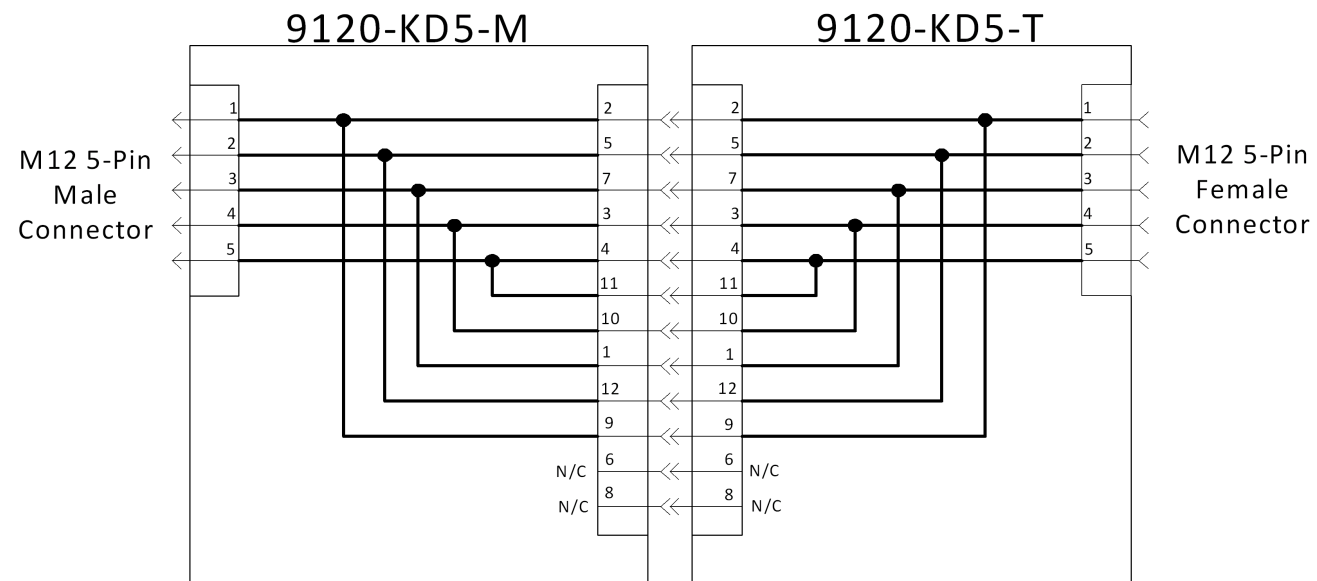

Notes:

- Pin 3 of the M12 5-Pin connector is First-to-mate Last-to-break at the Tool Changer interface. This pin is recommended for use as ground.
- The KD5 Master and Tool modules are potted with 3M DP270.

NOTES: UNLESS OTHERWISE SPECIFIED.

DO NOT SCALE DRAWING. ALL DIMENSIONS ARE IN MILLIMETERS.



1031 Goodworth Drive, Apex, NC 27539, USA
 Tel: +1.919.772.0115 Email: info@ati-ia.com
 Fax: +1.919.772.8259 www.ati-ia.com
 ISO 9001 Registered Company

PROPERTY OF ATI INDUSTRIAL AUTOMATION, INC. NOT TO BE REPRODUCED IN ANY MANNER EXCEPT ON ORDER OR WITH PRIOR WRITTEN AUTHORIZATION OF ATI.

DRAWN BY: W. Berrocal, 12/4/15		TITLE	
CHECKED BY: A. Strotzer, 12/16/15		KD5 Module Drawing	
SCALE	SIZE	DRAWING NUMBER	REVISION
2:1	B	9630-20-KD5	02
PROJECT # 150901-1 SHEET 1 OF 1			