

9121-JA2-M Air Adapter (Shown)

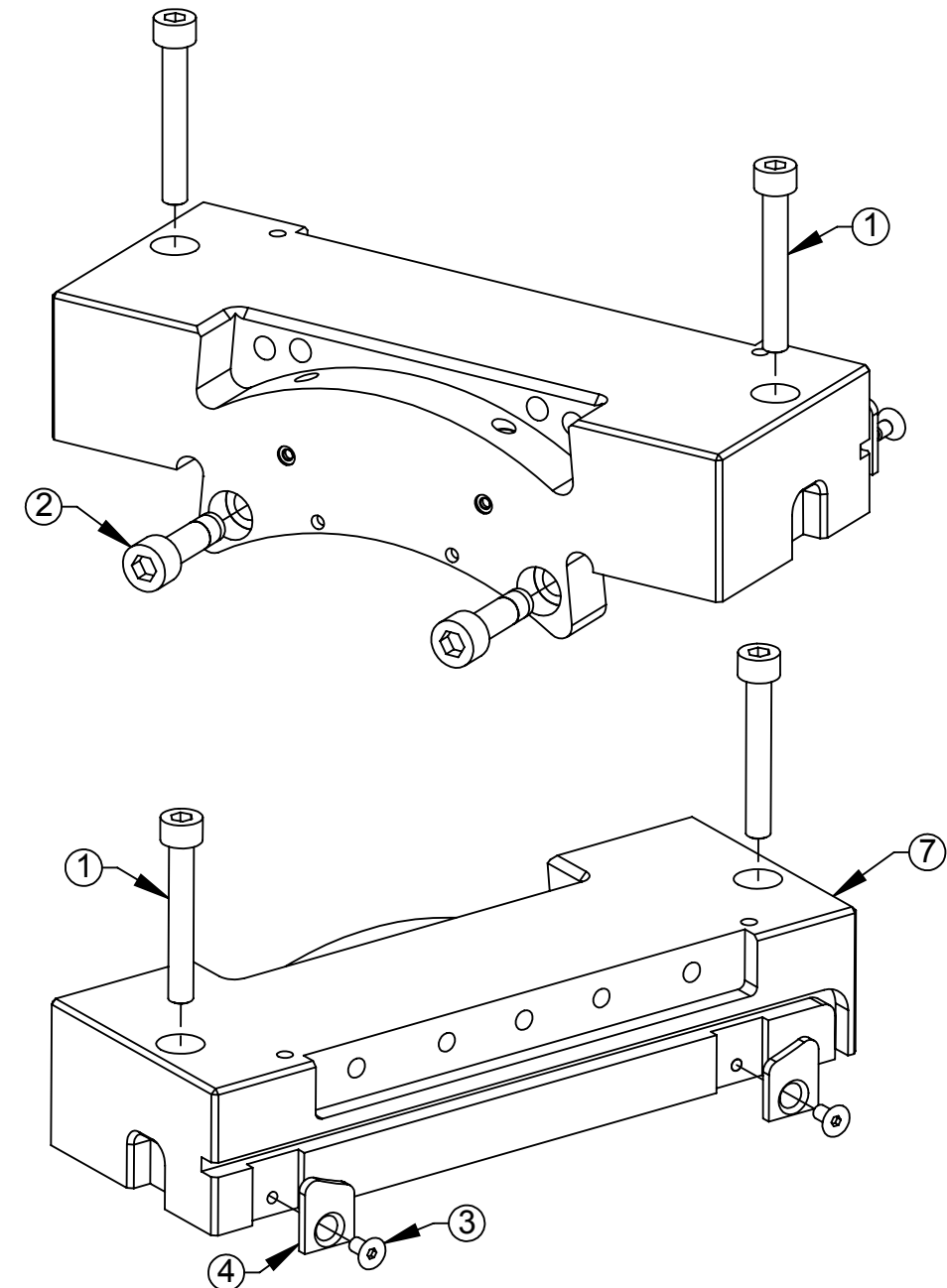
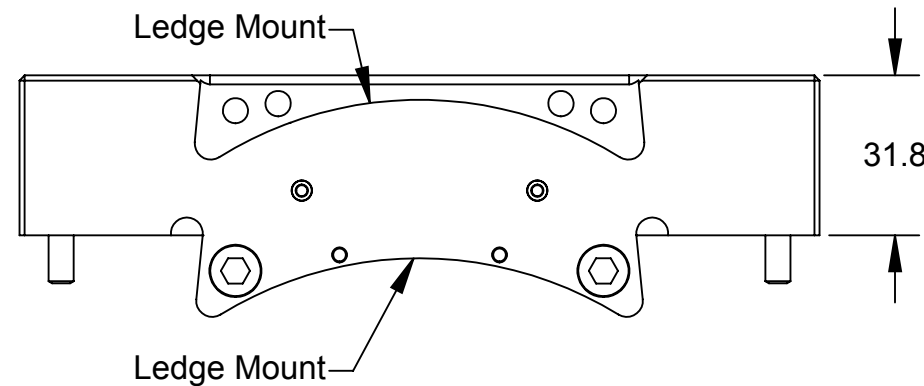
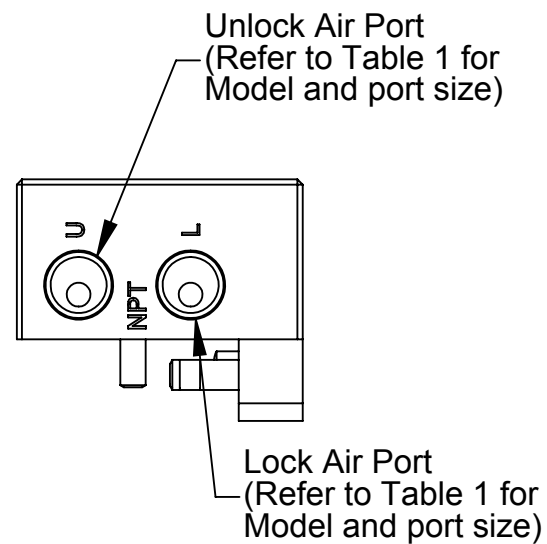

Table 1: Air Adapter Port Size

Air Adapter Model	Air Port Size
9121-JA2-M	1/4" NPT
9121-JB2-M	G 1/4 BSPP
9121-JP2-M	1/4 BSPT

ITEM NO.	QTY	PART NUMBER	DESCRIPTION
1	2	3500-1064035-15	M5-0.8 x 35mm SHCS, Blue
2	2	3500-1066020-15A	M6-1 x 20mm SHCS, Blue, Pre-Applied
3	2	3500-1258006-11	M3 x 6mm SFHCS Black Oxide
4	2	3700-20-3292	Cable Retaining Tab

- Notes:
- The air adapters are designed to mount to QC-113, QC-210, QC-213 Tool Changers and GL6L and GL7L Utility Couplers.
 - Other models are covered in the 9620-20-C-Jxx Air Adapters manual.
 - The air adapter should be supplied dry, non-lubricated air at 60 to 100 psi (4.1-6.9 Bar) and filtered at 40 microns or better.
 - It is important that exhaust mufflers are not restricted. As part of a preventative maintenance program, periodically inspect and/or replace the exhaust mufflers.

NOTES: UNLESS OTHERWISE SPECIFIED.

DO NOT SCALE DRAWING. ALL DIMENSIONS ARE IN MILLIMETERS.

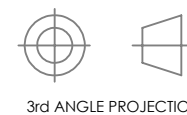

1031 Goodworth Drive, Apex, NC 27539, USA
 Tel: +1.919.772.0115 Email: info@ati-ia.com
 Fax: +1.919.772.8259 www.ati-ia.com
 ISO 9001 Registered Company

PROPERTY OF ATI INDUSTRIAL AUTOMATION, INC. NOT TO BE REPRODUCED IN ANY MANNER EXCEPT ON ORDER OR WITH PRIOR WRITTEN AUTHORIZATION OF ATI.

DRAWN BY: J. Handy, 1/7/16		TITLE	
CHECKED BY: W Berrocal, 9/9/16		Air Adapter, QC-210	
PROJECT #	SHEET 1 OF 1	SCALE	SIZE
		1:2	B
DRAWING NUMBER		REVISION	
9630-20-Jxx Air Adapters for QC-210		02	