

Rev.	Description	Initiator	Date
04	ECO 17429: Sheet 2: Corrected orientation of 3700-20-2000 Brass Collar in 9123-GA2M-0-0-N.	TBC	12/6/2018

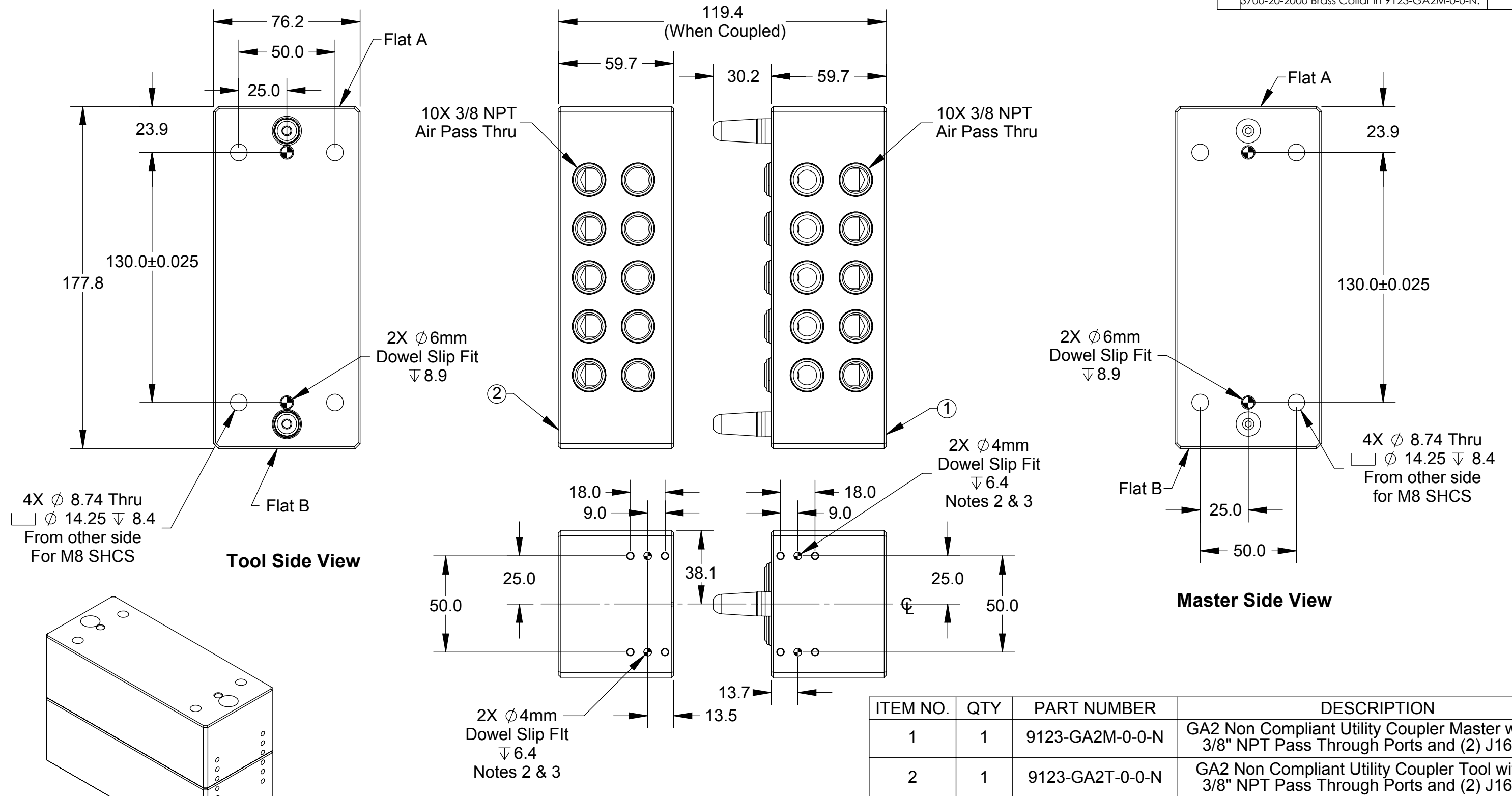

- Notes:
1. Continuous Coupling Force must be maintained in order to keep Master and Tool engaged.
 2. Pattern typical both ends.
 3. Pattern dimensions are reference only, and are intended for mounting ATI utility modules.

ITEM NO.	QTY	PART NUMBER	DESCRIPTION
1	1	9123-GA2M-0-0-N	GA2 Non Compliant Utility Coupler Master with (10) 3/8" NPT Pass Through Ports and (2) J16 Flats
2	1	9123-GA2T-0-0-N	GA2 Non Compliant Utility Coupler Tool with (10) 3/8" NPT Pass Through Ports and (2) J16 Flats

NOTES: UNLESS OTHERWISE SPECIFIED.
DO NOT SCALE DRAWING. ALL DIMENSIONS ARE IN MILLIMETERS.



1031 Goodworth Drive, Apex, NC 27539, USA
 Tel: +1.919.772.0115 Email: info@ati-ia.com
 Fax: +1.919.772.8259 www.ati-ia.com
 ISO 9001 Registered Company

PROPERTY OF ATI INDUSTRIAL AUTOMATION, INC. NOT TO BE REPRODUCED IN ANY MANNER EXCEPT ON ORDER OR WITH PRIOR WRITTEN AUTHORIZATION OF ATI.

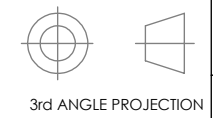

DRAWN BY: M. Perrault, 9/28/12		TITLE	
CHECKED BY: D. Norton, 10/16/12		GA2 Utility Coupler, NPT	
PROJECT # -	SHEET 1 OF 3	SCALE 1:2	SIZE B
		DRAWING NUMBER	REVISION
		9630-20-GA2-N	04

GA2 Utility Coupler Master Assembly, NPT

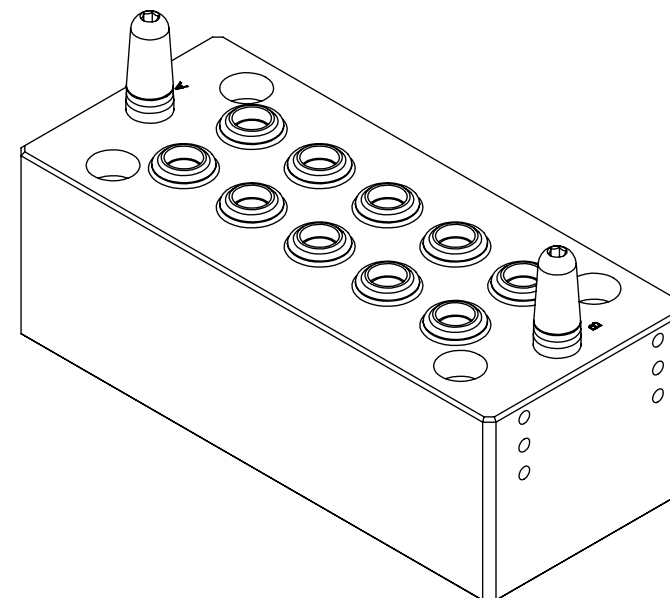
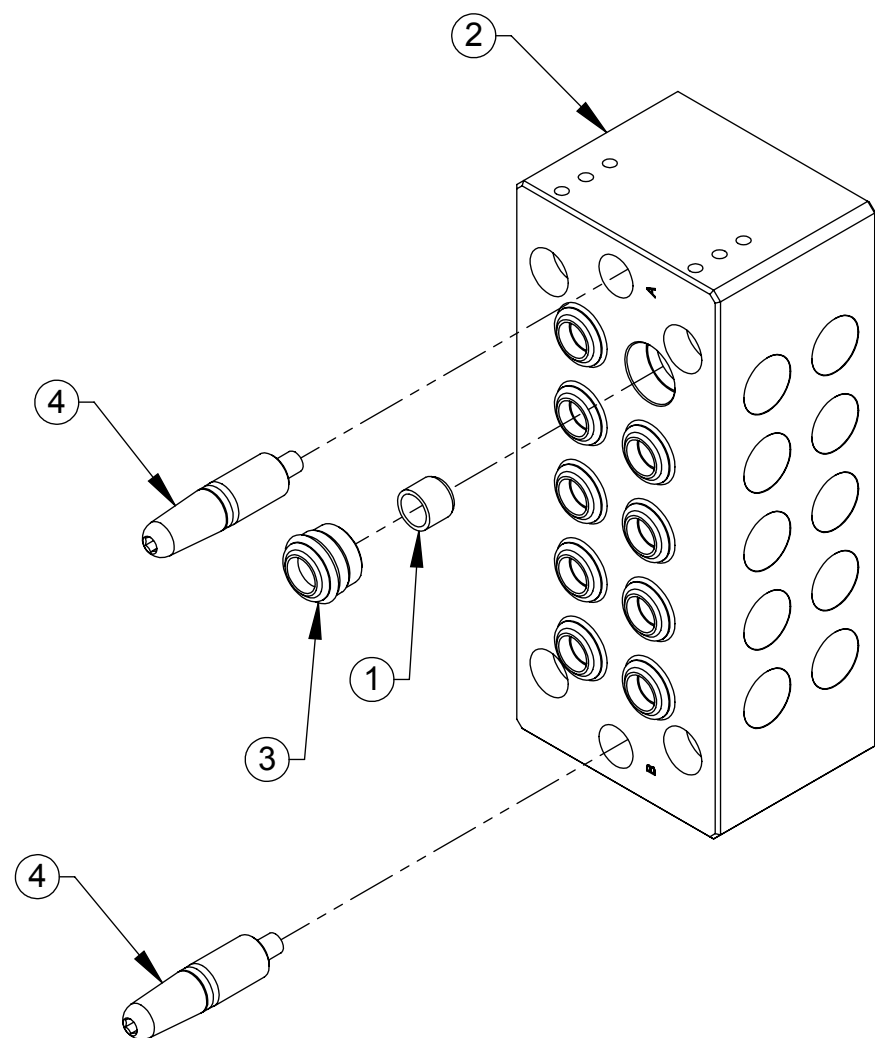

NOTES: UNLESS OTHERWISE SPECIFIED.

DO NOT SCALE DRAWING. ALL DIMENSIONS ARE IN MILLIMETERS.



3rd ANGLE PROJECTION



1031 Goodworth Drive, Apex, NC 27539, USA
 Tel: +1.919.772.0115 Email: info@ati-ia.com
 Fax: +1.919.772.8259 www.ati-ia.com
 ISO 9001 Registered Company

PROPERTY OF ATI INDUSTRIAL AUTOMATION, INC. NOT TO BE REPRODUCED IN ANY MANNER EXCEPT ON ORDER OR WITH PRIOR WRITTEN AUTHORIZATION OF ATI.

DRAWN BY: M. Perrault, 9/28/12		TITLE		
CHECKED BY: D. Norton, 10/16/12		GA2 Utility Coupler, NPT		
PROJECT # -	SHEET 2 OF 3	SCALE 1:2	SIZE B	DRAWING NUMBER 9630-20-GA2-N
				REVISION 04

GA2 Utility Coupler Tool Assembly, NPT

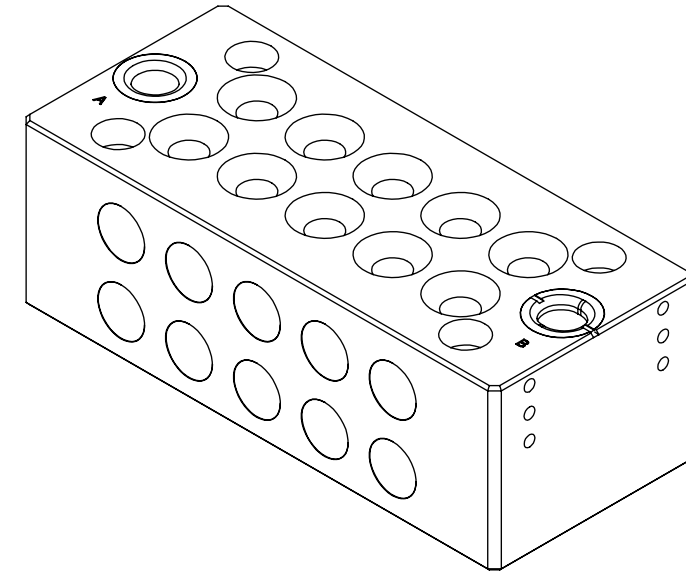
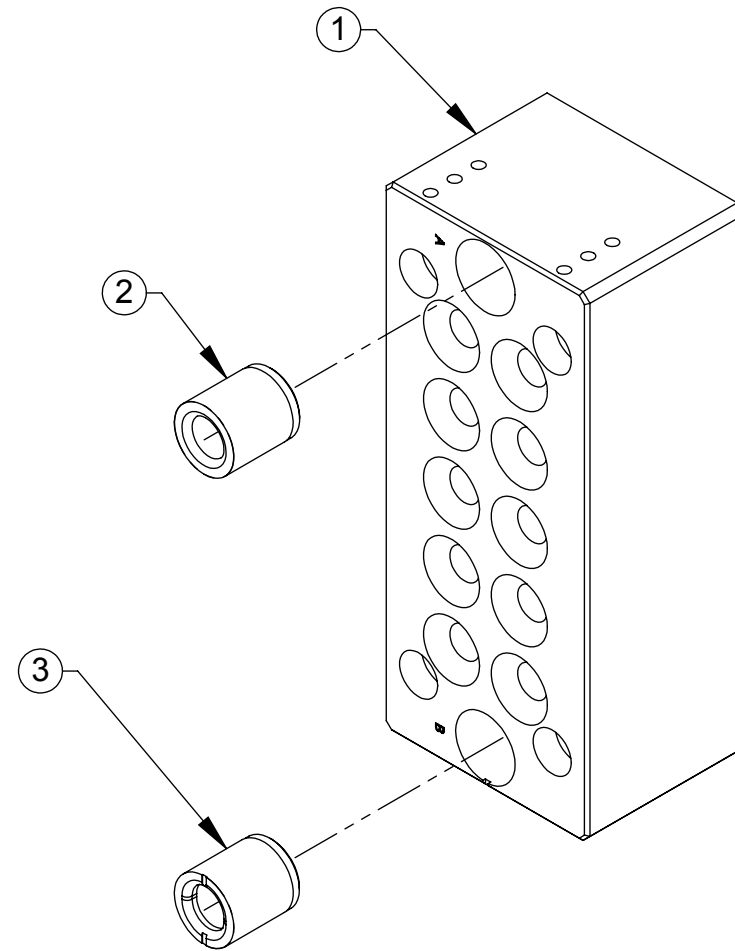

NOTES: UNLESS OTHERWISE SPECIFIED.

DO NOT SCALE DRAWING. ALL DIMENSIONS ARE IN MILLIMETERS.



3rd ANGLE PROJECTION



1031 Goodworth Drive, Apex, NC 27539, USA
 Tel: +1.919.772.0115 Email: info@ati-ia.com
 Fax: +1.919.772.8259 www.ati-ia.com
 ISO 9001 Registered Company

PROPERTY OF ATI INDUSTRIAL AUTOMATION, INC. NOT TO BE REPRODUCED IN ANY MANNER EXCEPT ON ORDER OR WITH PRIOR WRITTEN AUTHORIZATION OF ATI.

DRAWN BY: M. Perrault, 9/28/12		TITLE	
CHECKED BY: D. Norton, 10/16/12		GA2 Utility Coupler, NPT	
PROJECT # -	SHEET 3 OF 3	SCALE 1:2	SIZE B
		DRAWING NUMBER 9630-20-GA2-N	REVISION 04