

REV.	DESCRIPTION	INITIATOR	DATE
04	ECO 18152; Sheet 3: Replace 3700-20-1460 with 3610-2712500-20.	TBC	8/8/2019

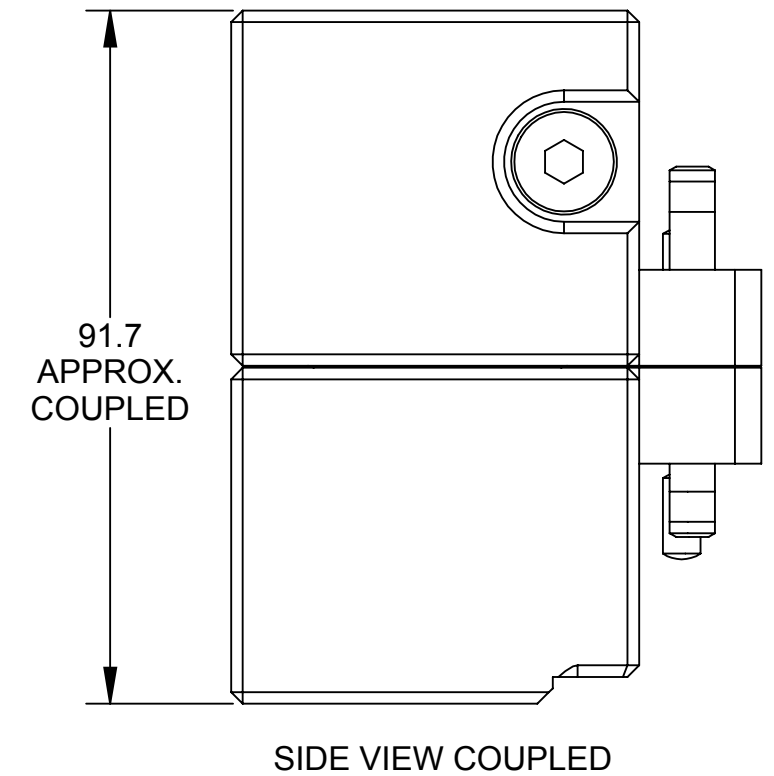
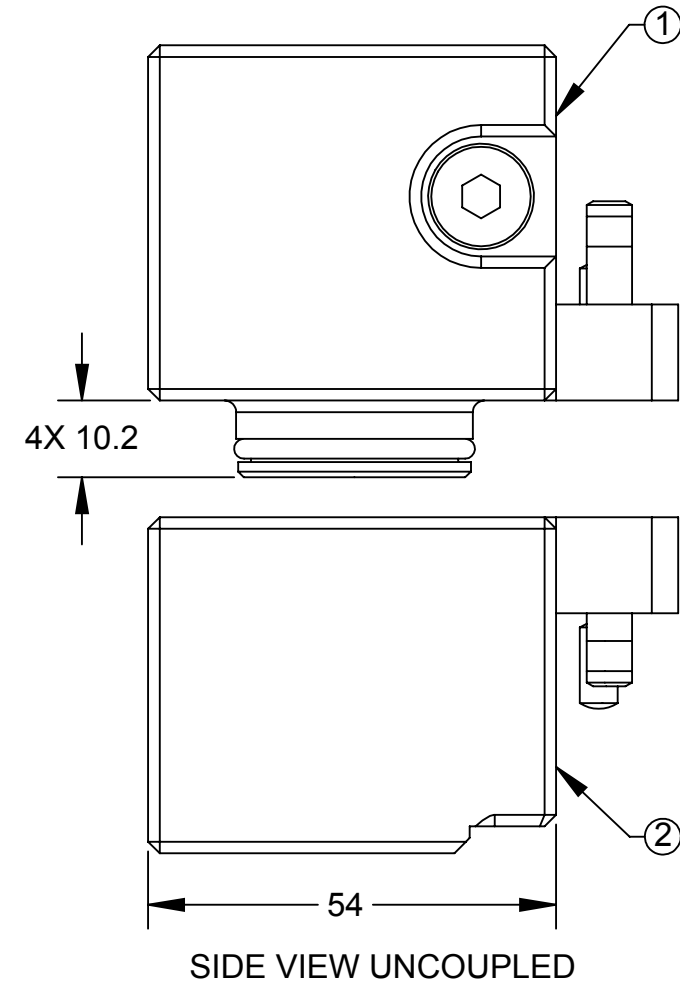
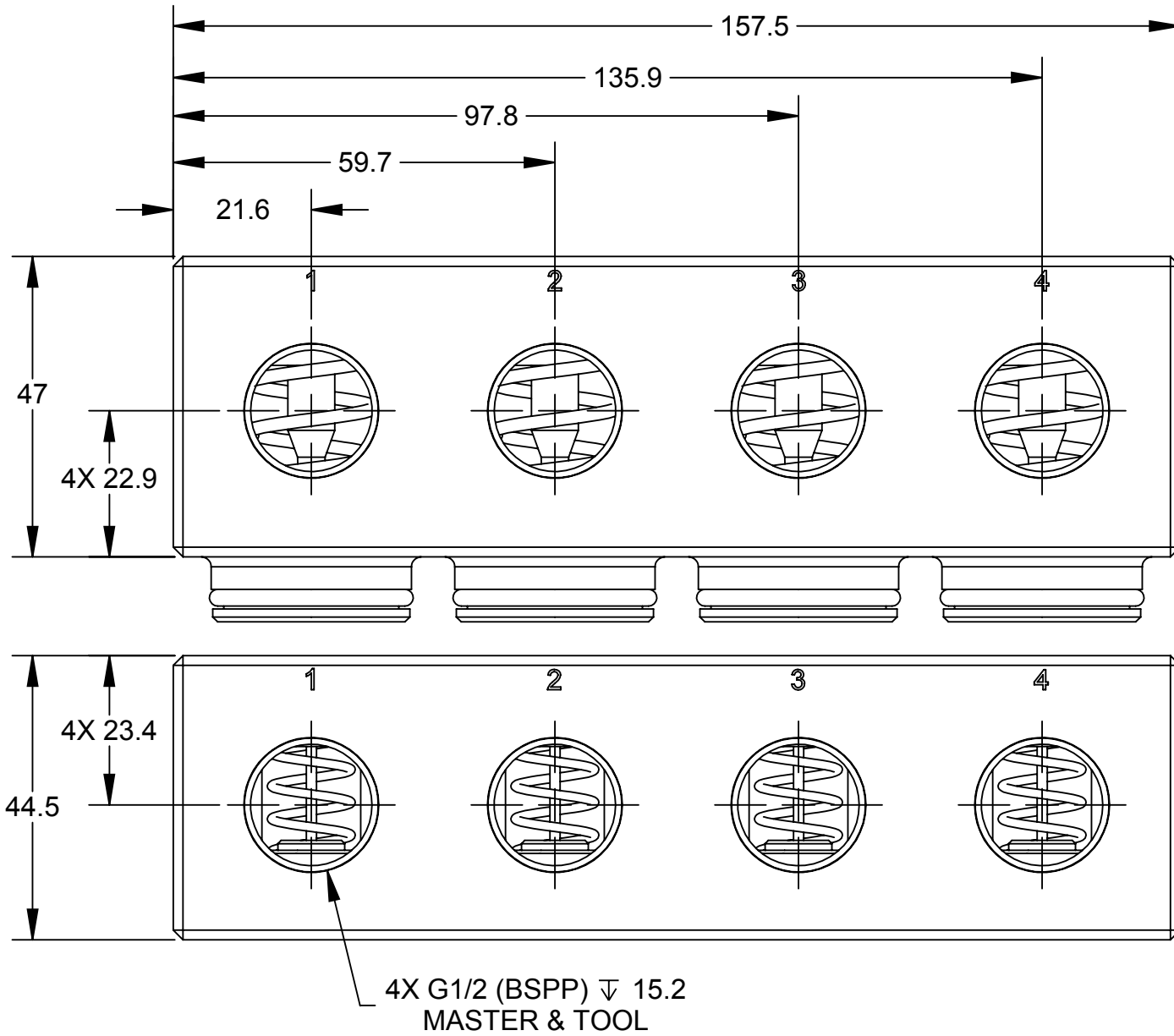

ITEM NO.	QTY	PART NUMBER	DESCRIPTION
1	1	9121-FH12-M	STAINLESS STEEL FLUID/AIR MODULE WITH (4) G1/2 (BSPP) SELF-SEALING PORTS, 3/8 VALVE COMPONENTS, NIPPLE PORT WITH RADIAL SEAL, MASTER SIDE
2	1	9121-FH12-T	STAINLESS STEEL FLUID/AIR MODULE WITH (4) G1/2 (BSPP) SELF-SEALING PORTS, 3/8 VALVE COMPONENTS, C-BORE FOR NIPPLE PORT, TOOL SIDE

NOTES:
MATERIALS OF CONSTRUCTION:
1. HOUSINGS: STAINLESS STEEL
2. VALVE COMPONENTS: STAINLESS STEEL, PVC, NITRILE
3. G1/8 PLUG: NICKEL PLATED BRASS

OPERATIONS:
4. FOR BEST RESULTS ENSURE FLUIDS ARE NEAR NEUTRAL pH, MINIMIZE FLUID PARTICULATE SIZE AND KEEP FLUID MODULE MATING SURFACES FREE AND CLEAR OF ANY DEBRIS.
5. CHECKED PORTS CAN PRODUCE SIGNIFICANT FORCES WHEN UNDER HIGH SUPPLY PRESSURES. SEE PRODUCT MANUAL REGARDING PROPER OPERATING PROCEDURE.

NOTES: UNLESS OTHERWISE SPECIFIED.

DO NOT SCALE DRAWING. ALL DIMENSIONS ARE IN MILLIMETERS.



3rd ANGLE PROJECTION



1031 Goodworth Drive, Apex, NC 27539, USA
Tel: +1.919.772.0115 Email: info@ati-ia.com
Fax: +1.919.772.8259 www.ati-ia.com
ISO 9001 Registered Company

PROPERTY OF ATI INDUSTRIAL AUTOMATION, INC. NOT TO BE REPRODUCED IN ANY MANNER EXCEPT ON ORDER OR WITH PRIOR WRITTEN AUTHORIZATION OF ATI.

DRAWN BY: K. ZACHARY 12/04/17		TITLE	
CHECKED BY: B. KENDRICK 12/08/17		FH12 FLUID/AIR MODULE DRAWING	
PROJECT # 170515-3	SHEET 1 OF 3	SCALE 1:1	SIZE B
DRAWING NUMBER 9630-20-FH12		REVISION 04	

FH12-M SERVICEABLE PARTS

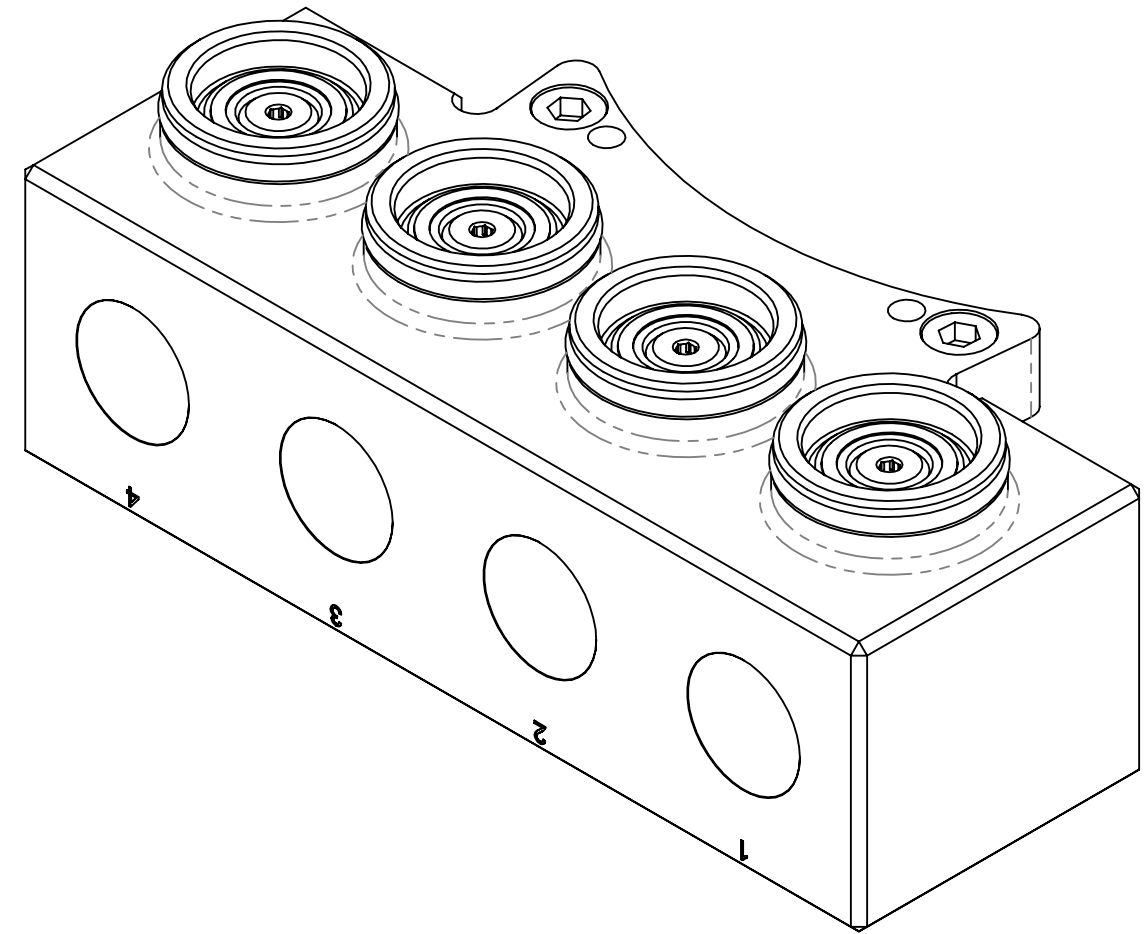
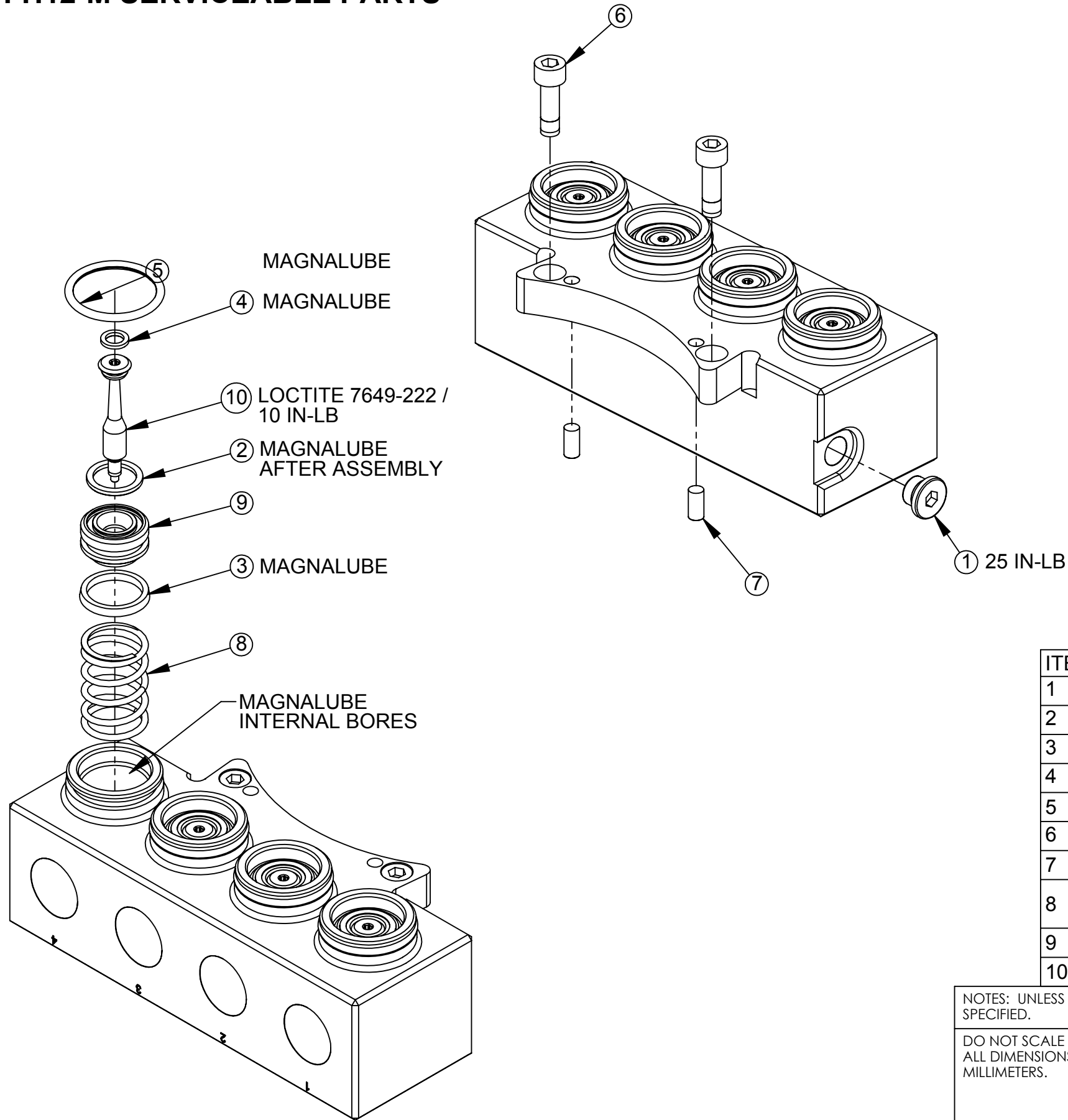

ITEM NO.	QTY	PART NUMBER	DESCRIPTION
1	1	3405-1000002-00	G1/8 Plug, Hex Socket, O-Ring Seal
2	4	3410-0001065-01	O-Ring 14MM X 2MM Buna
3	4	3410-0001068-01	Mini U-Cup Seal 18mm ID x 22mm Buna
4	4	3410-0001183-01	O-Ring 6MM X 2MM Buna D90
5	4	3410-0001477-01	O-RING, AS568-121, BUNA-N, D70
6	2	3500-1066020-21A	M6-1 x 20mm SHCS, SS, Pre-Applied
7	2	3540-0105010-21	5mm x 10mm Dowel Pin SST
8	4	3610-1912501-21	COMPRESSION SPRING, .845" OD, 1.250 FREE LENGTH, 31.7 LB/IN RATE, STAINLESS STEEL
9	4	3700-20-2994	Master Check Valve Piston
10	4	3700-20-10503	VALVE STEM, 3/8 TALL VALVE, M4 THREAD

NOTES: UNLESS OTHERWISE SPECIFIED.

DO NOT SCALE DRAWING. ALL DIMENSIONS ARE IN MILLIMETERS.



3rd ANGLE PROJECTION



1031 Goodworth Drive, Apex, NC 27539, USA
 Tel: +1.919.772.0115 Email: info@ati-ia.com
 Fax: +1.919.772.8259 www.ati-ia.com
 ISO 9001 Registered Company

PROPERTY OF ATI INDUSTRIAL AUTOMATION, INC. NOT TO BE REPRODUCED IN ANY MANNER EXCEPT ON ORDER OR WITH PRIOR WRITTEN AUTHORIZATION OF ATI.

DRAWN BY: K. ZACHARY 12/04/17

CHECKED BY: B. KENDRICK 12/08/17

PROJECT # 170515-3 SHEET 2 OF 3

TITLE
FH12 FLUID/AIR MODULE DRAWING

SCALE
1:1

SIZE
B

DRAWING NUMBER
9630-20-FH12

REVISION
04

FH12-T SERVICEABLE PARTS

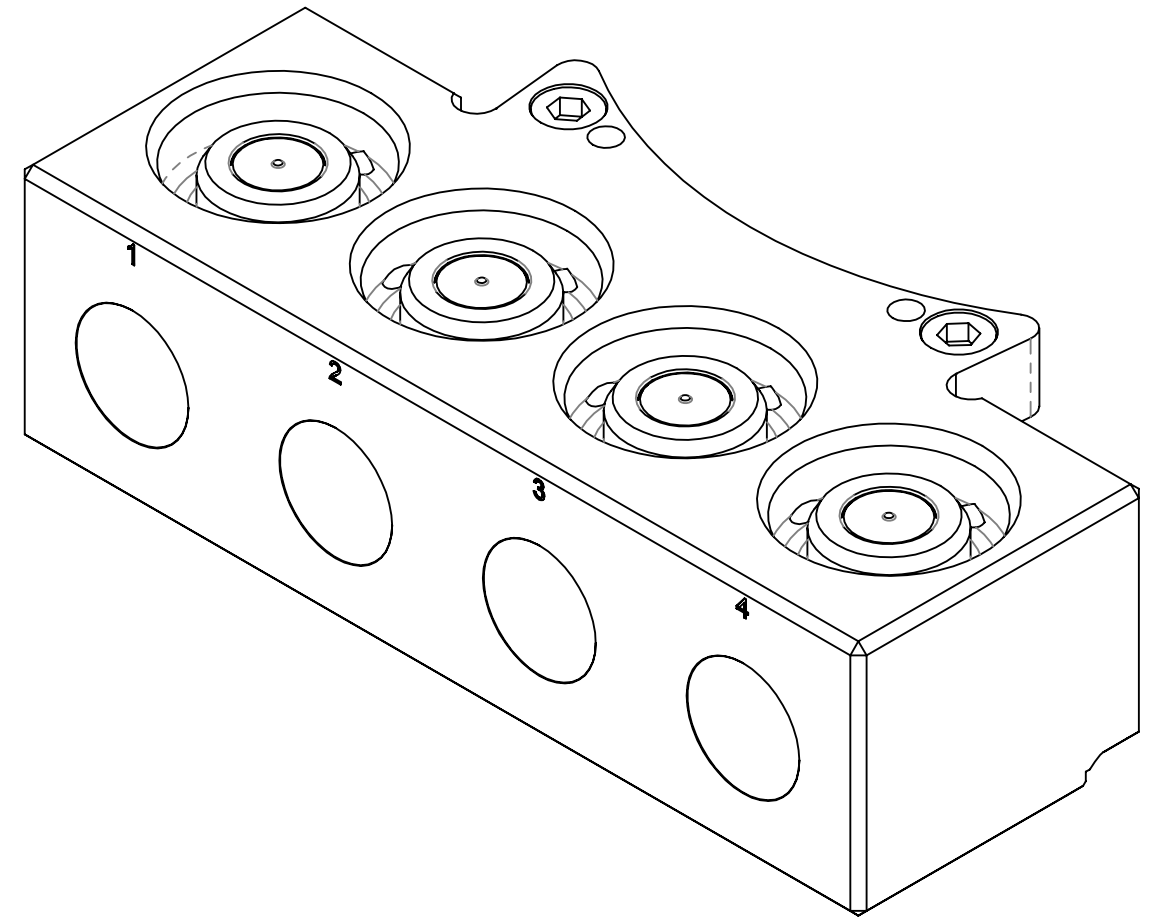
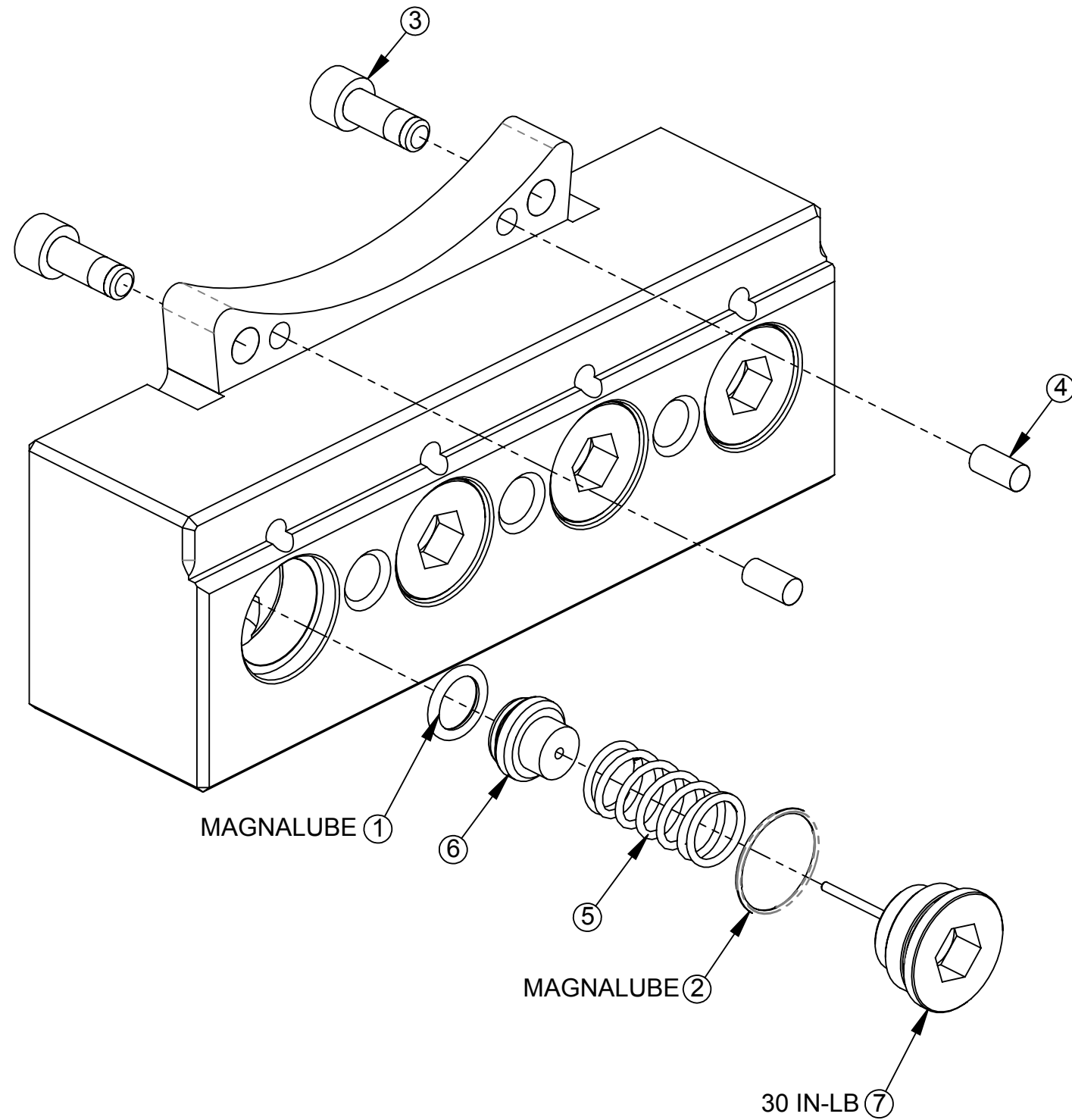

ITEM NO.	QTY	PART NUMBER	DESCRIPTION
1	4	3410-0001067-01	O-ring, 10mm x 2mm, Buna N, Dur. 90
2	4	3410-0001284-01	O-ring, .669OD x .047 wall, 70D, Buna-N
3	2	3500-1066016-21A	M6-1 x 16mm SHCS, SS, Pre-Applied
4	2	3540-0105010-21	5mm x 10mm Dowel Pin SST
5	4	3610-2712500-20	Spring, Fluid/Air Module, Tool
6	4	3700-20-1457	Tool Fluid/Air Check Valve Piston
7	4	9005-20-1515	3/8" Check Port Long Plug with Dowel

NOTES: UNLESS OTHERWISE SPECIFIED.

DO NOT SCALE DRAWING. ALL DIMENSIONS ARE IN MILLIMETERS.



3rd ANGLE PROJECTION



1031 Goodworth Drive, Apex, NC 27539, USA
 Tel: +1.919.772.0115 Email: info@ati-ia.com
 Fax: +1.919.772.8259 www.ati-ia.com
 ISO 9001 Registered Company

PROPERTY OF ATI INDUSTRIAL AUTOMATION, INC. NOT TO BE REPRODUCED IN ANY MANNER EXCEPT ON ORDER OR WITH PRIOR WRITTEN AUTHORIZATION OF ATI.

DRAWN BY: K. ZACHARY 12/04/17		TITLE	
CHECKED BY: B. KENDRICK 12/08/17		FH12 FLUID/AIR MODULE DRAWING	
PROJECT # 170515-3	SHEET 3 OF 3	SCALE 1:1	SIZE B
		DRAWING NUMBER 9630-20-FH12	REVISION 04