

Rev.	Description	Initiator	Date
06	ECO 19691; Part number engraving removed, dowel holes for clear assembly removed	EPR	2/17/2021

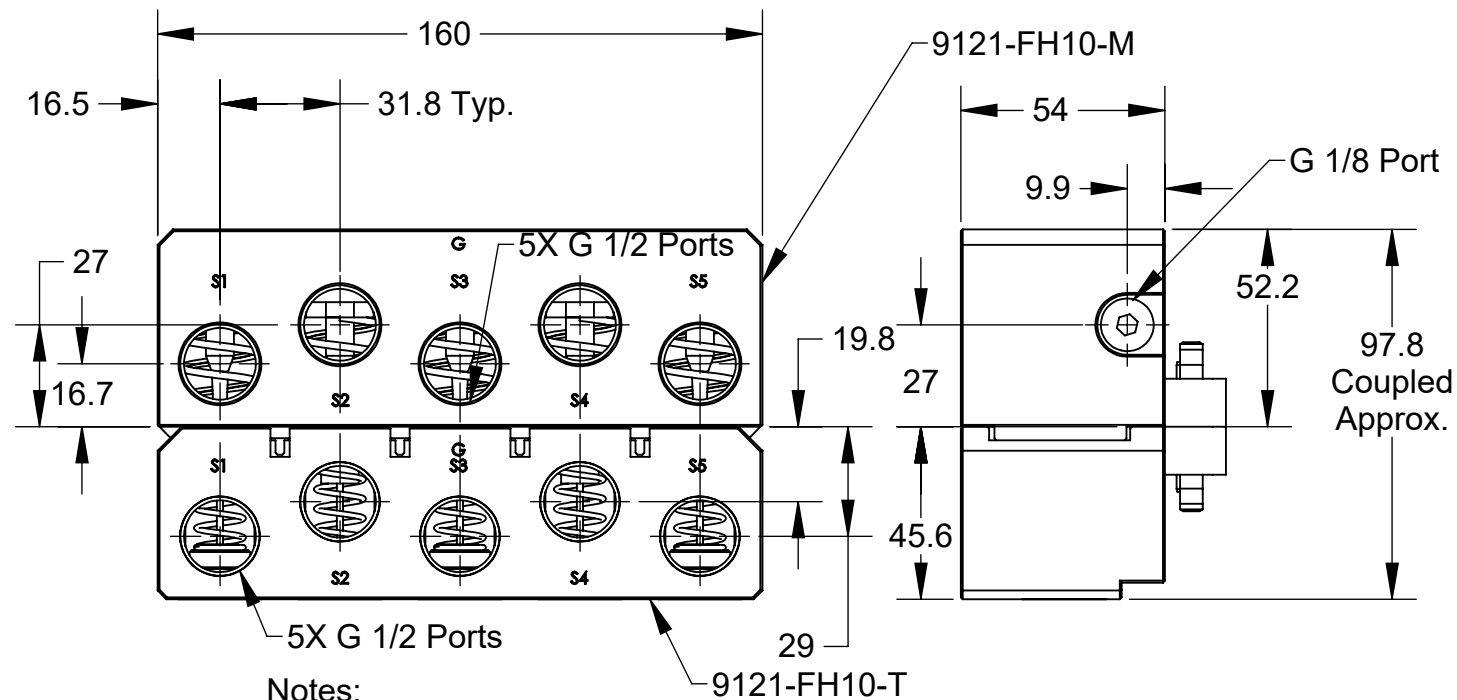
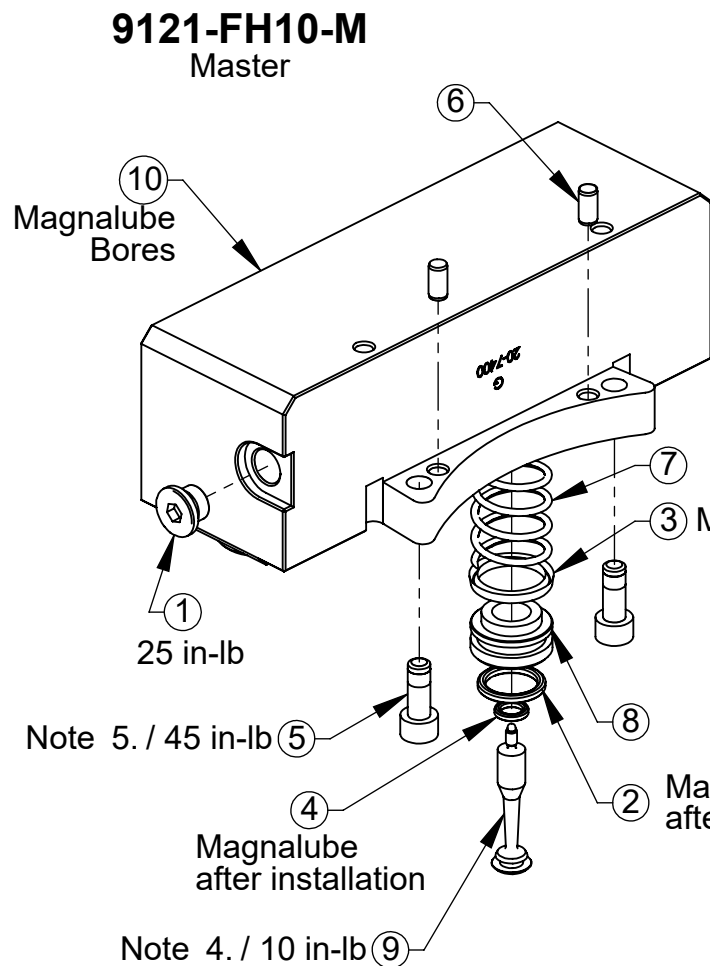

Notes:

Material of Construction:

- Housings - Stainless Steel
- Valve Components - Stainless Steel, PVC & Nitrile
- G 1/8 Plug - Nickel Plated Brass
- Replacement stem contains pre-applied thread locker. Use Loctite 7649 primer and Loctite 222 if reassembling with original stem.
- Replacement screw contains pre-applied thread locker. Use Loctite 7649 primer and Loctite 242 if reassembling with original screw.

Operations:

- For best results ensure fluids are near neutral pH, minimize fluid particulate size and keep fluid module mating surfaces free and clear of any debris.
- Checked ports can produce significant forces when under high supply pressures. See product manual regarding proper operating procedure.

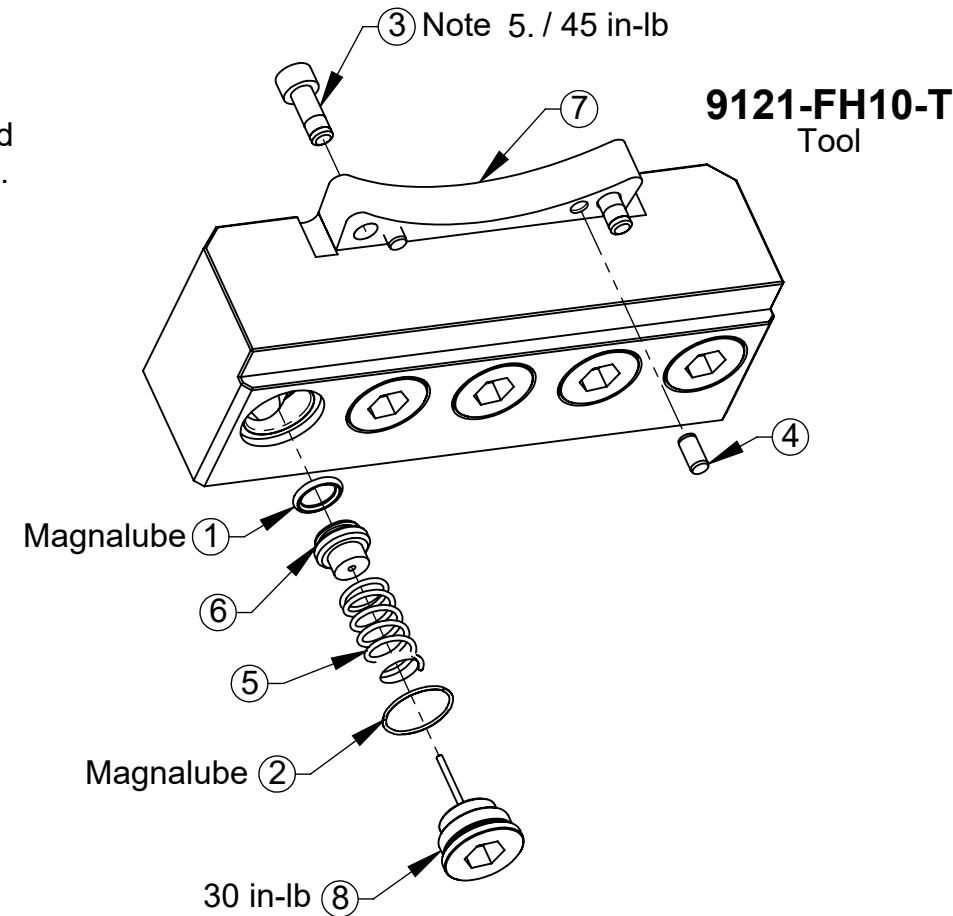

ITEM NO.	QTY.	PART NUMBER	DESCRIPTION
1	1	3405-1000002-00	G1/8 Plug, Hex Socket, O-Ring Seal
2	5	3410-0001065-01	O-Ring 14MM X 2MM Buna
3	5	3410-0001068-01	Mini U-Cup Seal 18mm ID x 22mm Buna
4	5	3410-0001183-01	O-Ring 6MM X 2MM Buna D90
5	2	3500-1066016-21A	M6-1 x 16mm SHCS, SS, Pre-Applied
6	2	3540-0105010-21	5mm x 10mm Dowel Pin SST
7	5	3610-3312500-20	Spring, Fluid/Air Module, Master
8	5	3700-20-2994	Master Check Valve Piston
9	5	3700-20-2996	VALVE STEM, HIGH STRENGTH
10	1	3700-20-7400	FH10 Housing, Master

Note: Service Kit 9120-F2-M-Kit consists of (1) each of items 2, 3, 4, & 7.

ITEM NO.	QTY.	PART NUMBER	DESCRIPTION
1	5	3410-0001067-01	O-ring, 10mm x 2mm, Buna N, Dur. 90
2	5	3410-0001284-01	O-ring, .669OD x .047 wall, 70D, Buna-N
3	2	3500-1066016-21A	M6-1 x 16mm SHCS, SS, Pre-Applied
4	2	3540-0105010-21	5mm x 10mm Dowel Pin SST
5	5	3610-2712500-20	Spring, Fluid/Air Module, Tool
6	5	3700-20-1457	Tool Fluid/Air Check Valve Piston
7	1	3700-20-7401	FH10 Housing, Tool
8	5	9005-20-1515	3/8" Check Port Long Plug with Dowel

Note: Service Kit 9120-F1-T-Kit consists of (1) each of items 1, 2, & 5.

NOTES: UNLESS OTHERWISE SPECIFIED.

DO NOT SCALE DRAWING. ALL DIMENSIONS ARE IN MILLIMETERS.

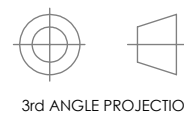

1031 Goodworth Drive, Apex, NC 27539, USA
 Tel: +1.919.772.0115 www.ati-ia.com
 Fax: +1.919.772.8259 ISO 9001 Registered Company

PROPERTY OF ATI INDUSTRIAL AUTOMATION, INC. NOT TO BE REPRODUCED IN ANY MANNER EXCEPT ON ORDER OR WITH PRIOR WRITTEN AUTHORIZATION OF ATI.

DRAWN BY: D.Lawson-1/17/12		TITLE	
CHECKED BY: D.Swanson-1/31/12		FH10 Module Drawing	
SCALE	SIZE	DRAWING NUMBER	REVISION
1:2	B	9630-20-FH10	06
PROJECT # 110207-1		SHEET 1 OF 1	