

Rev.	Description	Initiator	Date
03	Changed TSI Circuit Wiring and Back to 19-Pin Block	RLH	8/17/06
04	Added Sheet 3, Schematic	RLH	9/29/06
05	ECO 7797: Change connector part number. Updated title blocks.	ATM	06/07/2010

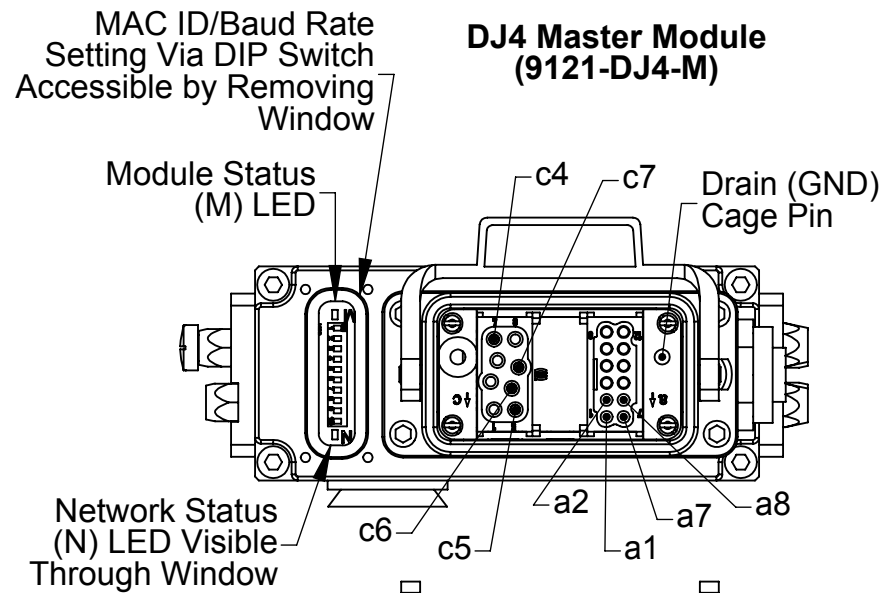

5-Pin Mini Female	Harting 10B	Signal Description
1	Cage Pin	Drain(GND)
2	a1	CAN V+
3	a2	CAN V-
4	a7	CAN_H
5	a8	CAN_L
	c4	Aux V+
	c5	Aux V-
	c6	Spare 1
	c7	Spare 2

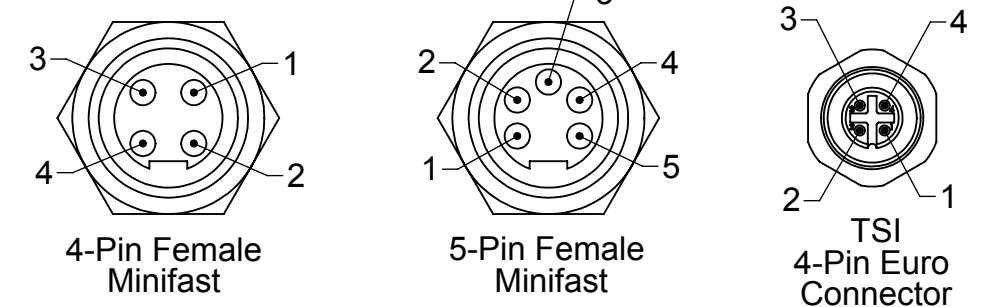
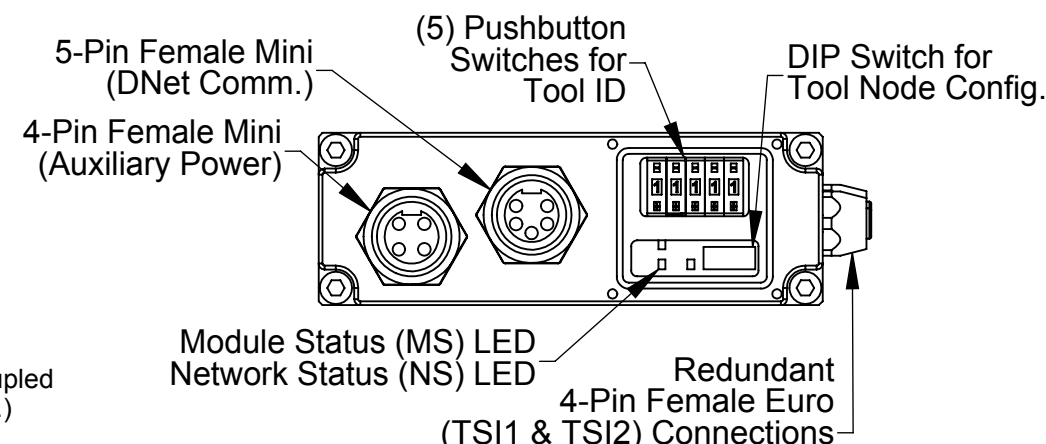
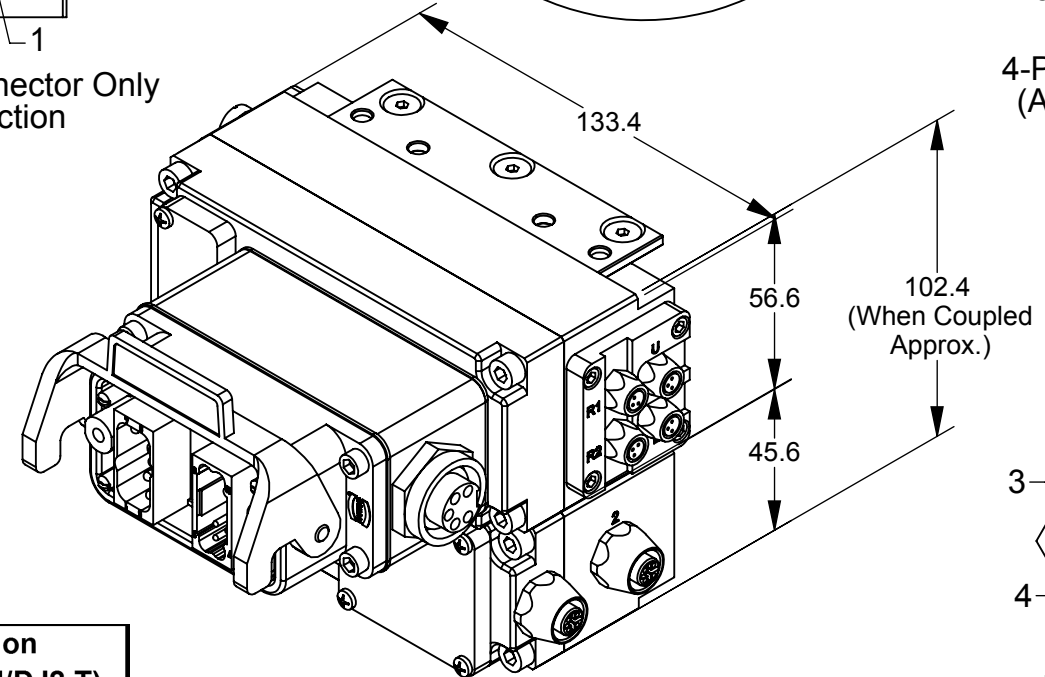
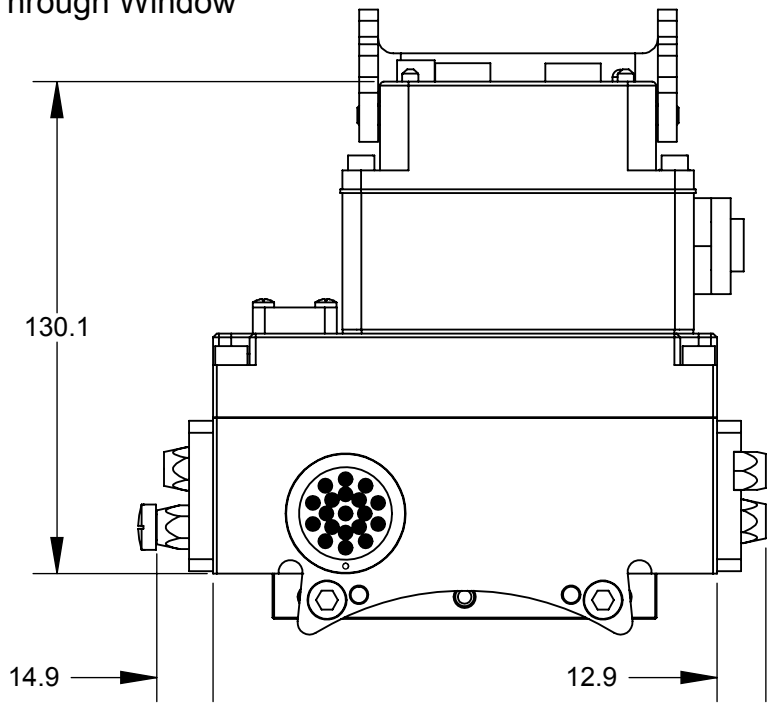
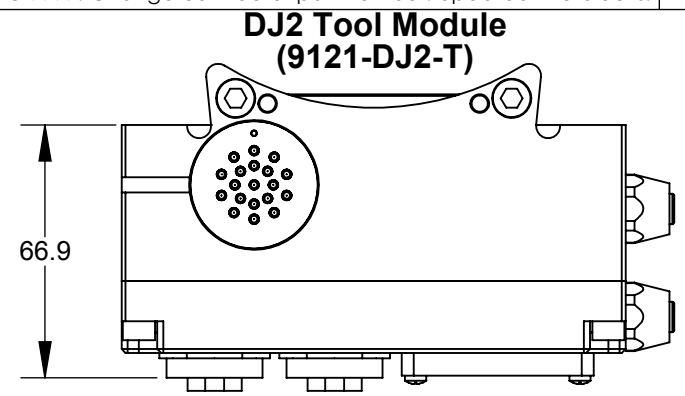
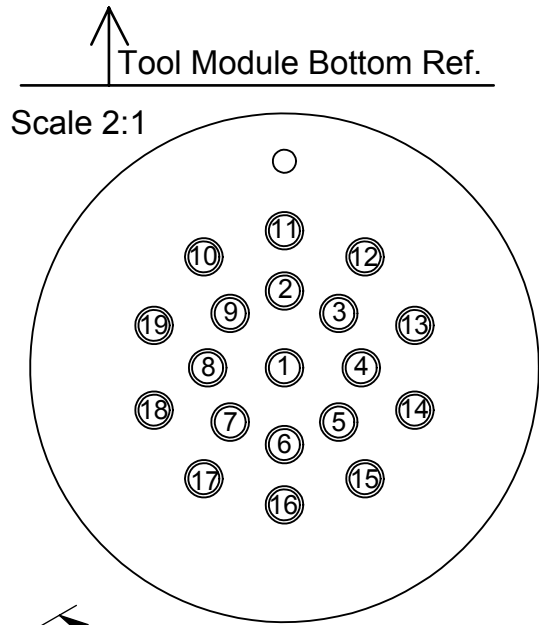
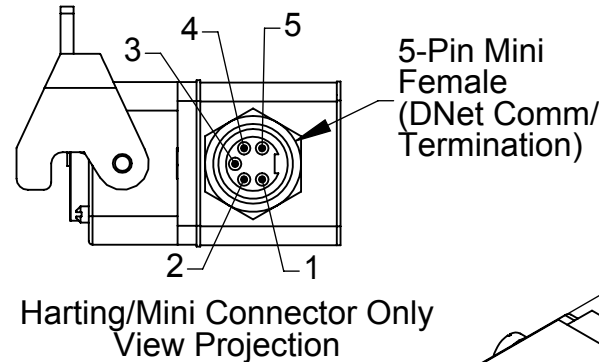

Signal Description	19-Pin Block (DJ4-M/DJ2-T)
1	CAN V-
2	TSRV2
3	TSIV2
4	Drain
5	Aux Spare 2
6	RS 485-
7	CAN_L
8	TSRV1
9	TSIV1
10	Aux V+
11	Aux Spare 1
12	Tool Presence
13	Aux V-
14	TSI Out2
15	CAN_H
16	RS 485+
17	Spare Input/ N/C
18	TSI In1
19	CAN V+

- Notes:**
- The modules are shown at sheet scale. All connector face views are shown at a 1:1 scale, except as noted.
  - The 9121-DJ2-T module supports the use of a (2) mechanical limit switches for integration with the dual redundant TSI feature.
  - Harting, Aux (4-Pin) and Bus (5-Pin) Connectors are oriented as shown on the Modules.

Mini Connector Wiring Info. Tool			
4-Pin Connector		5-Pin Connector	
4-Pin	Description	5-Pin	Description
1	Aux V+	2	CAN V+
2	Spare 1	3	CAN V-
3	Spare 2	4	CAN_H
4	Aux V-	5	CAN_L

Euro Connector Wiring Info. (TSI Typical)	
4-Pin Euro Connector	Description
1	CAN V+
2	CAN V-
3	Relay Control
4	TSIV Input

NOTES: UNLESS OTHERWISE SPECIFIED  
DO NOT SCALE DRAWING. DRAWN IN SOLIDWORKS.  
ALL DIMENSIONS ARE IN MILLIMETERS.

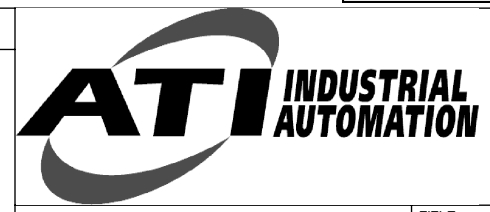

1031 Goodworth Drive, Apex, NC 27539, USA  
Tel: +1.919.772.0115 Email: info@ati-ia.com  
Fax: +1.919.772.8259 www.ati-ia.com  
ISO 9001 Registered Company

PROPERTY OF ATI INDUSTRIAL AUTOMATION, INC. NOT TO BE REPRODUCED IN ANY MANNER EXCEPT ON ORDER OR WITH PRIOR WRITTEN AUTHORIZATION OF ATI.

DRAWN BY: R. Heavner, 6/27/06	TITLE: DJ4M DJ2T Module Drawing		
CHECKED BY: B. Digeso, 6/27/06	SCALE: 1:2	SIZE: B	DRAWING NUMBER: 9630-20-DJ4 DJ2
WEIGHT LBS: 3.73	DATE: 051215-1		REVISION: 05
ASSEMBLY REF:	PRODUCT RELEASE # 051215-1		SHEET 1 OF 3

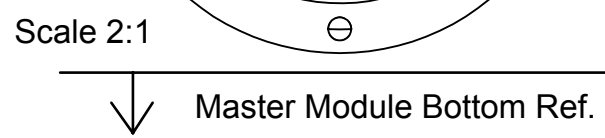
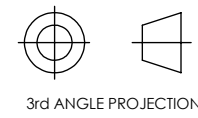

Rev.	Description	Initiator	Date
-	See Sheet 1	-	-

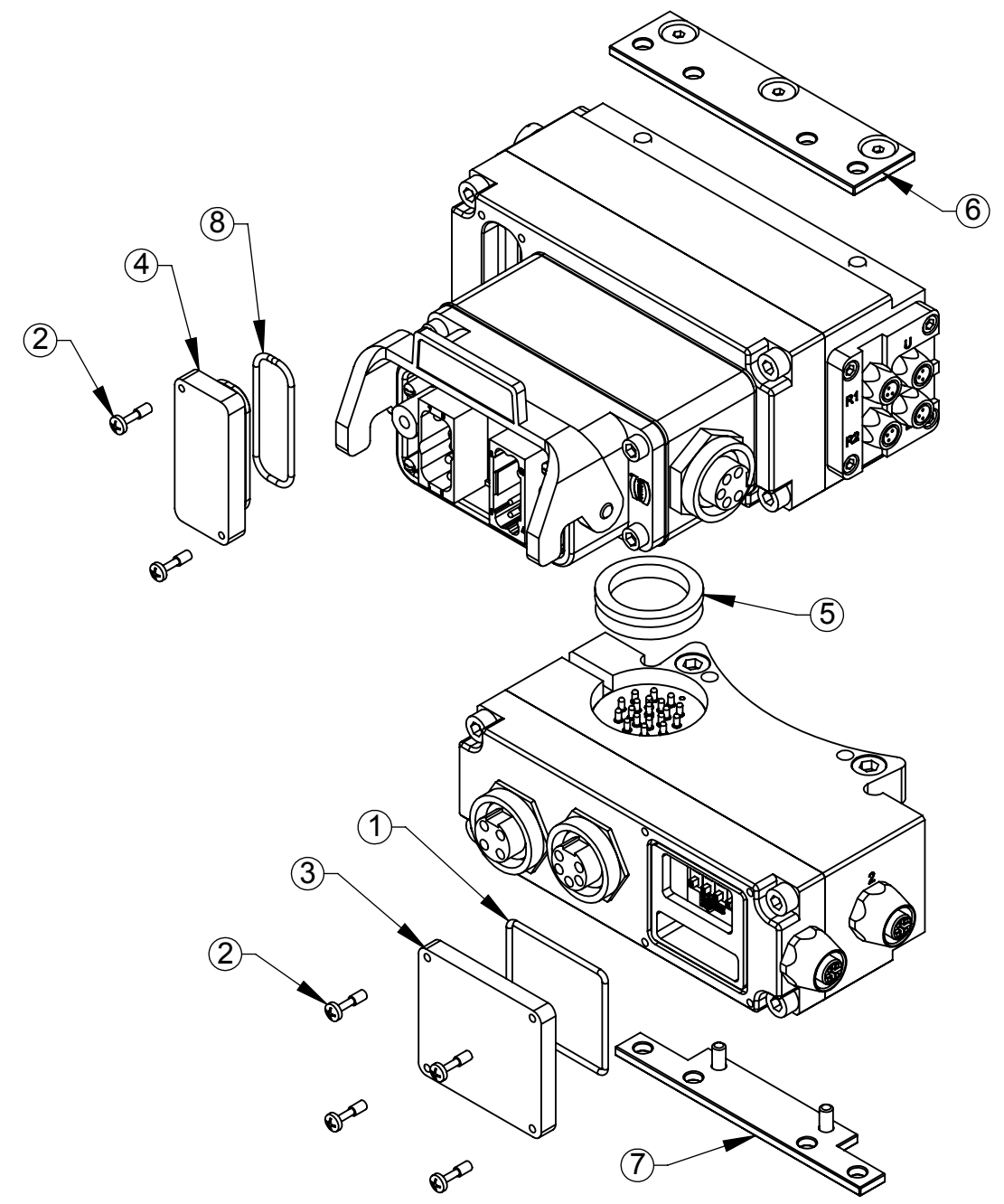
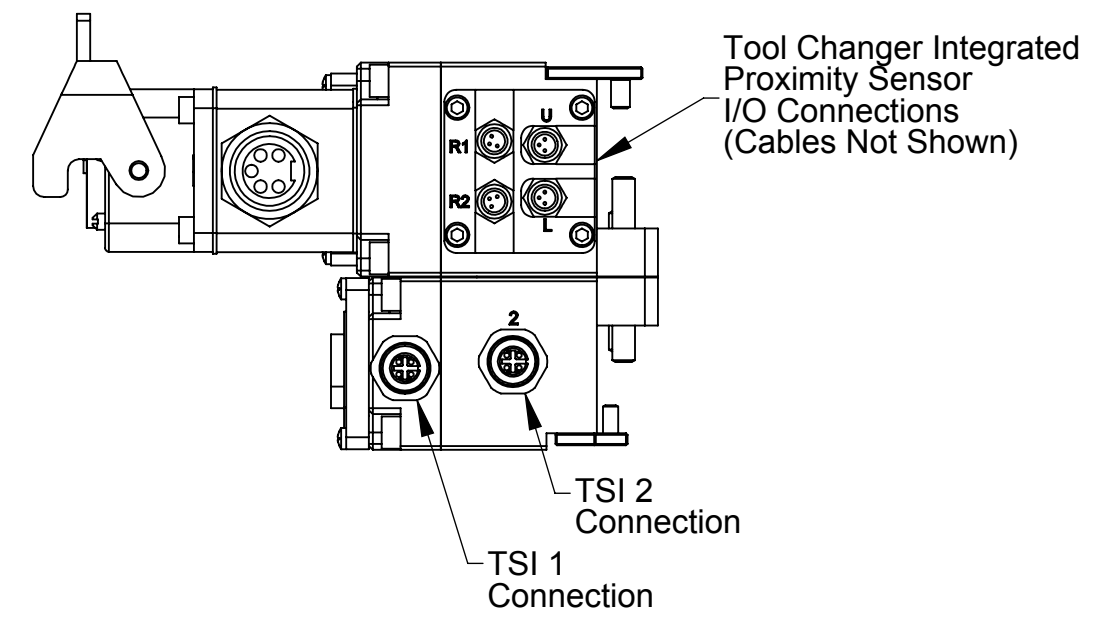
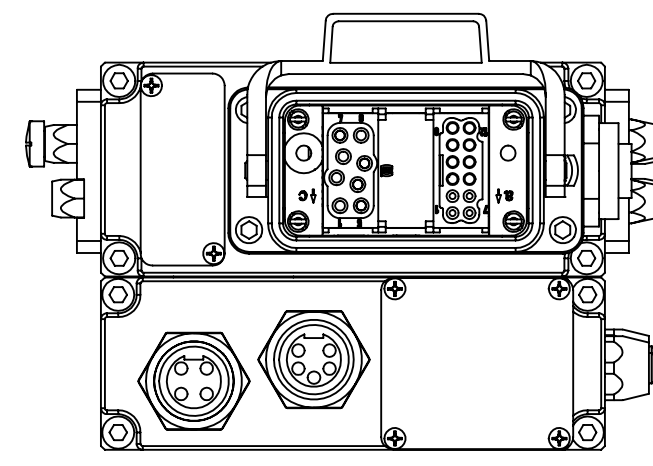
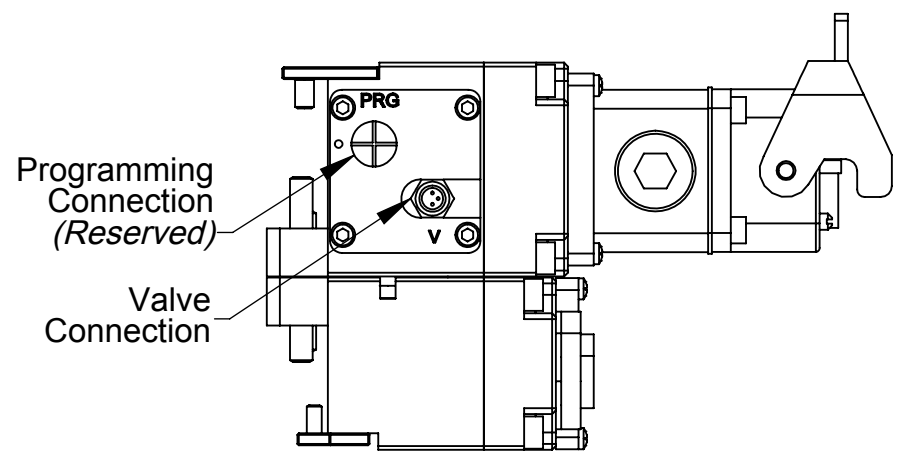

### DJ4-M/DJ2-T Serviceable Parts

ITEM NO.	QTY.	PART NUMBER	DESCRIPTION
1	1	3410-0001021-01	O-RING AS568-031
2	6	3500-9957012-21	CAPTIVE SCREW M3 X 12 SLOTTED HEAD SS
3	1	3700-20-3058	Insta-Tool Window, Tool
4	1	3700-20-4820	Window, Master, DJ Module, Anular Seal
5	1	4010-0000030-01	V-Ring Seal
6	1	9005-20-1198	Master Cleat Assembly
7	1	9005-20-1199	Tool Cleat Assembly
8	1	3410-0001201-01	O-Ring, AS568-024

NOTES: UNLESS OTHERWISE SPECIFIED  
DO NOT SCALE DRAWING. DRAWN IN SOLIDWORKS.  
ALL DIMENSIONS ARE IN MILLIMETERS.

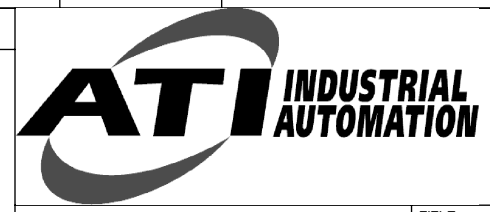

1031 Goodworth Drive, Apex, NC 27539, USA  
Tel: +1.919.772.0115 Email: info@ati-ia.com  
Fax: +1.919.772.8259 www.ati-ia.com  
ISO 9001 Registered Company

PROPERTY OF ATI INDUSTRIAL AUTOMATION, INC. NOT TO BE REPRODUCED IN ANY MANNER EXCEPT ON ORDER OR WITH PRIOR WRITTEN AUTHORIZATION OF ATI.

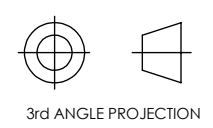

DRAWN BY: R. Heavner, 6/27/06		TITLE: DJ4M DJ2T Module Drawing		
CHECKED BY: B. Digeso, 6/27/06		SCALE: 1:2	SIZE: B	DRAWING NUMBER: 9630-20-DJ4 DJ2
WEIGHT LBS: 3.73		PRODUCT RELEASE # 051215-1		REVISION: 05
ASSEMBLY REF:		DATE:		SHEET 2 OF 3

Rev.	Description	Initiator	Date
-	See Sheet1	-	-

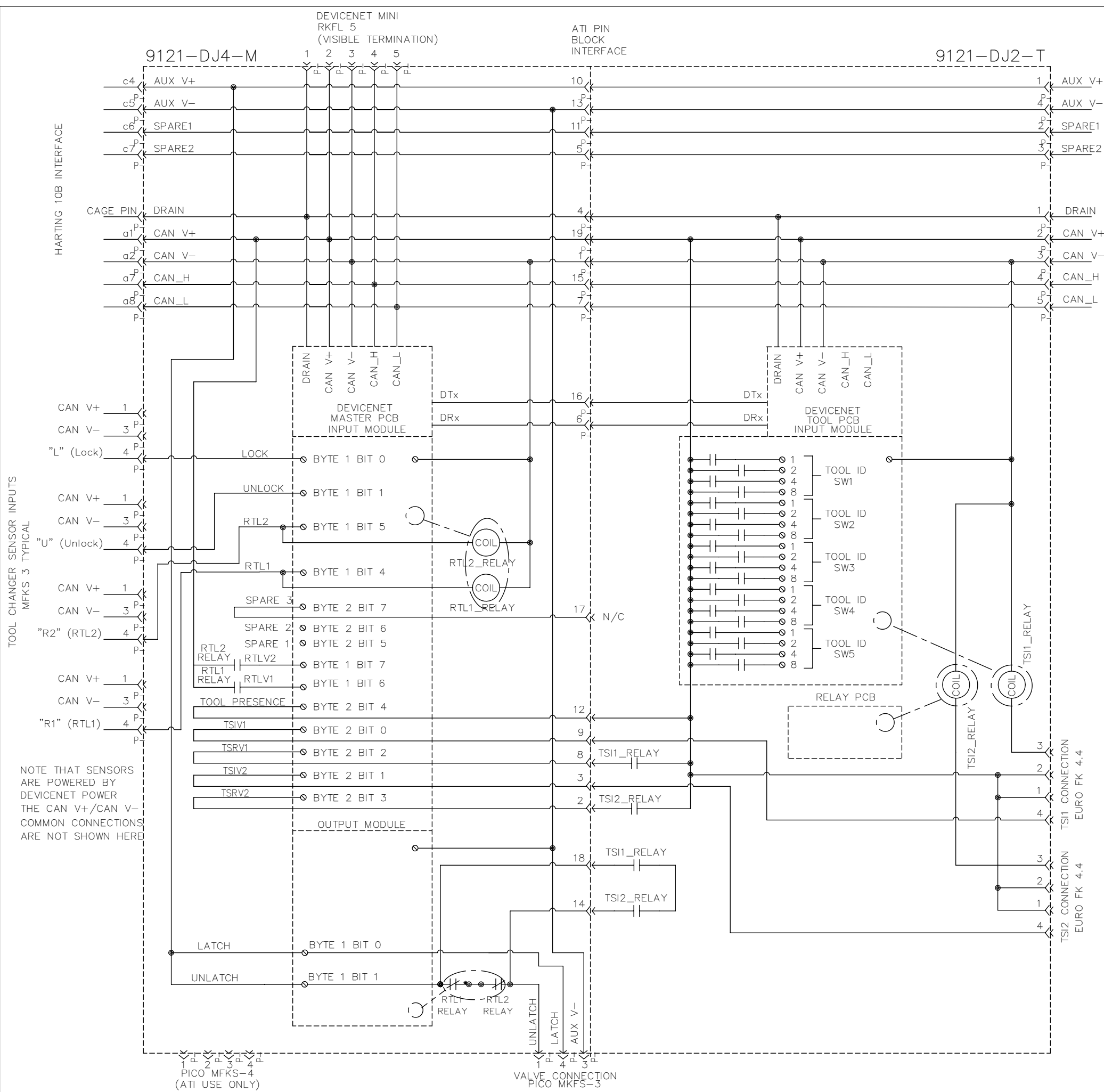

AUX MINI  
RKFL 4

DEVICENET  
MINI  
RKFL 5

NOTE:  
LIMIT SWITCHES SUPPLIED  
BY ATI AS #9005-20-1165  
SWITCH MUST HAVE (2) SETS  
OF NO CONTACTS, DPST

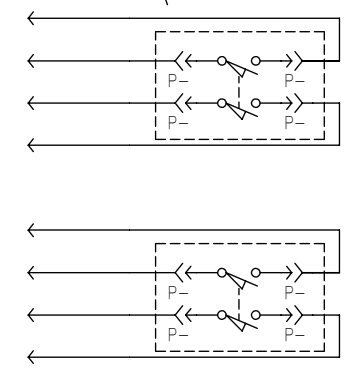

NOTES: UNLESS OTHERWISE SPECIFIED  
DO NOT SCALE DRAWING. DRAWN IN SOLIDWORKS.  
ALL DIMENSIONS ARE IN MILLIMETERS.

3rd ANGLE PROJECTION

1031 Goodworth Drive, Apex, NC 27539, USA  
Tel: +1.919.772.0115 Email: info@ati-ia.com  
Fax: +1.919.772.8259 www.ati-ia.com  
ISO 9001 Registered Company

PROPERTY OF ATI INDUSTRIAL AUTOMATION, INC. NOT TO BE REPRODUCED IN ANY MANNER EXCEPT ON ORDER OR WITH PRIOR WRITTEN AUTHORIZATION OF ATI.

DRAWN BY:	R. Heavner, 6/27/06	TITLE		
CHECKED BY:	B. Digeso, 6/27/06	DJ4M DJ2T Module Drawing		
WEIGHT LBS:	3.73	SCALE	SIZE	DRAWING NUMBER
ASSEMBLY REF:		1:2	B	9630-20-DJ4 DJ2
		PRODUCT RELEASE #	051215-1	REVISION
				05
		SHEET		3 OF 3