

Rev.	Description	Initiator	Date
04	Added Sheet 3, Schematic	RLH	9/29/06
05	Removed Limit Switches, Sheet 3	RLH	2/2/2007
06	ECO 7797: Change connector part number. Updated title blocks.	ATM	06/07/2010

- Notes:**
- The modules are shown at sheet scale. All connector face views are shown at a 1:1 scale, except as noted.
  - The 9121-DJ2-T module supports the use of a (2) mechanical limit switches for integration with the dual redundant TSI feature.
  - Mini-style Aux (4-Pin) and Bus (5-Pin) Connectors are oriented as shown on the Modules.

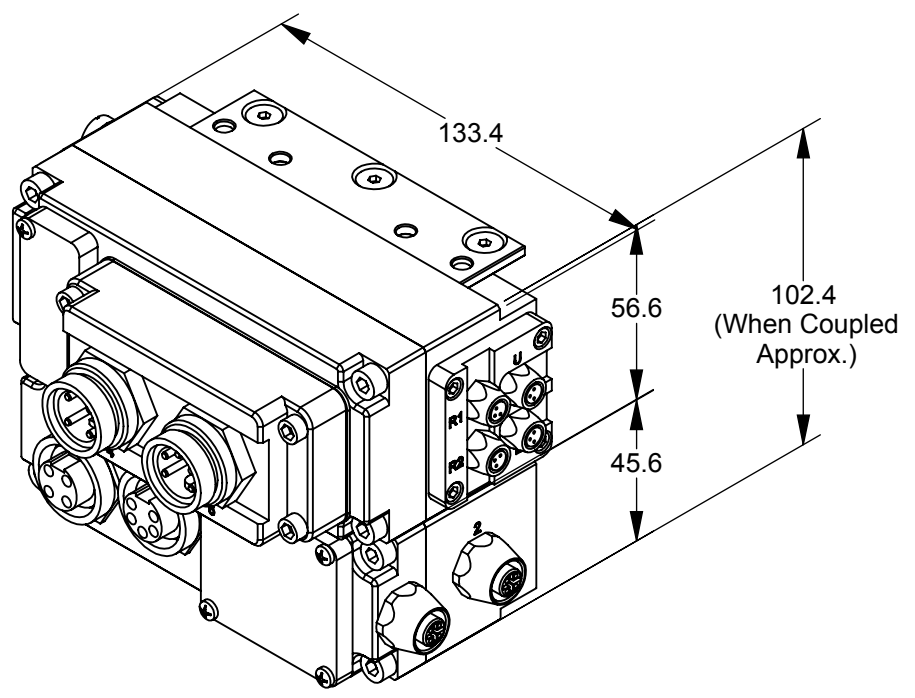

Signal Description	
19-Pin Block	(DJ3-M/DJ2-T)
1	CAN V-
2	TSRV2
3	TSIV2
4	Drain
5	Aux Spare 2
6	DRx
7	CAN_L
8	TSRV1
9	TSIV1
10	Aux V+
11	Aux Spare 1
12	Tool Presence
13	Aux V-
14	TSI Out2
15	CAN_H
16	DTx
17	Spare Input/ N/C
18	TSI In1
19	CAN V+

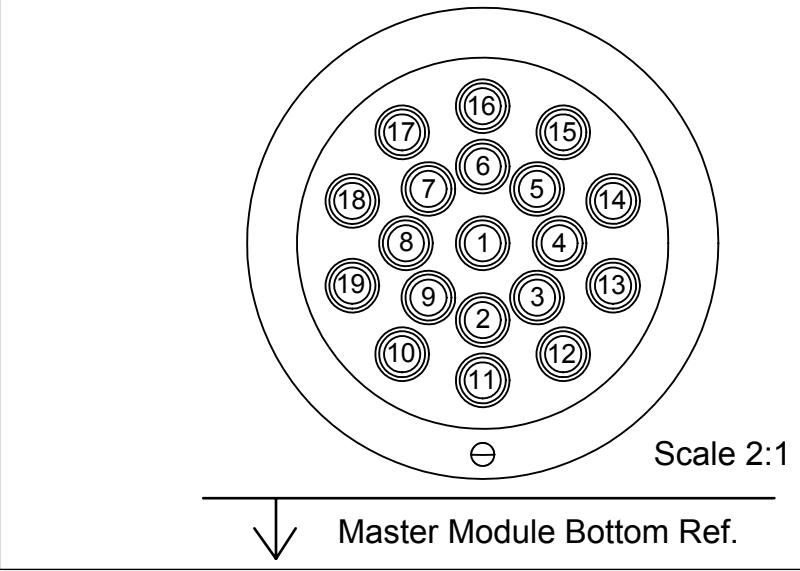
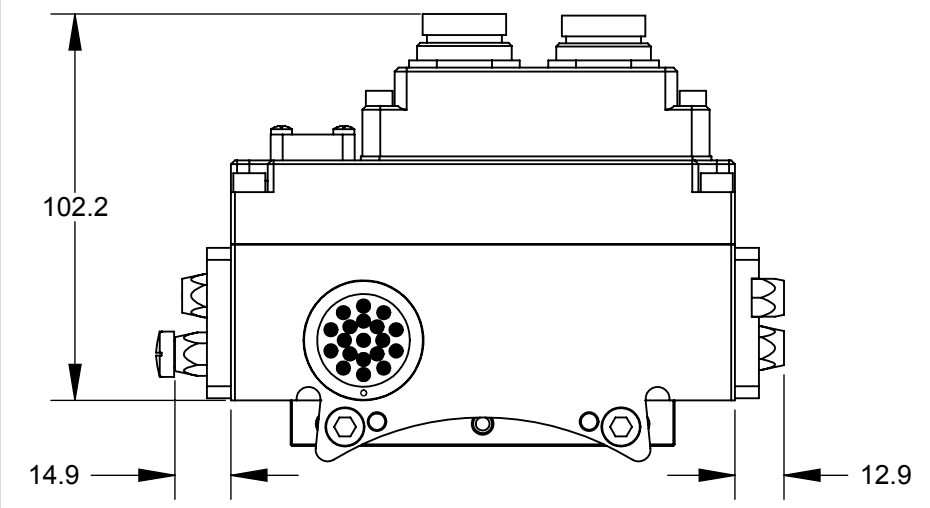
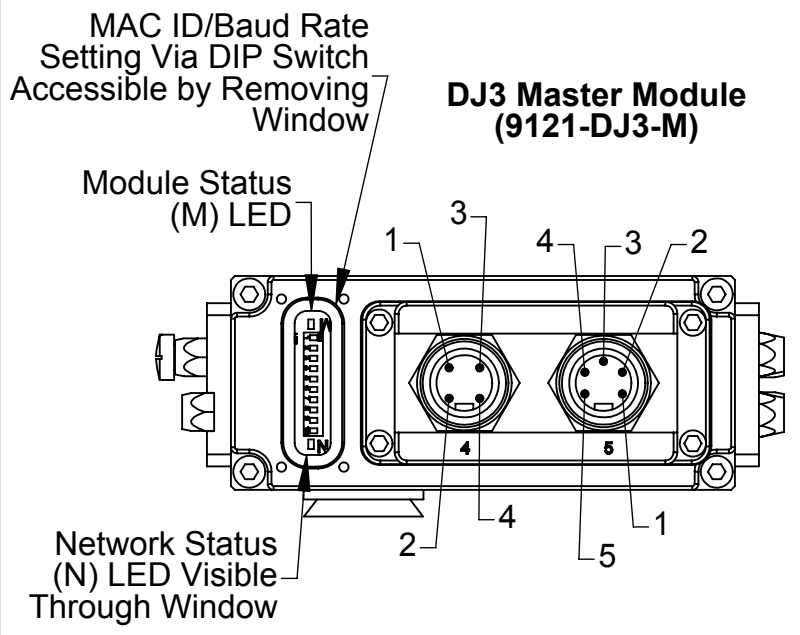
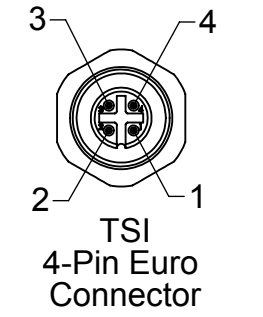
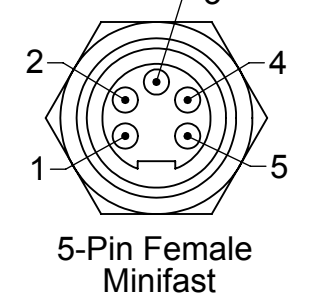
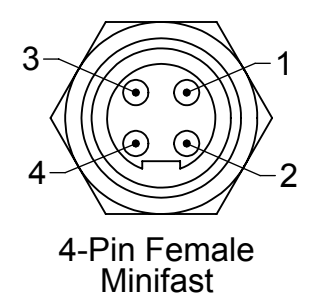
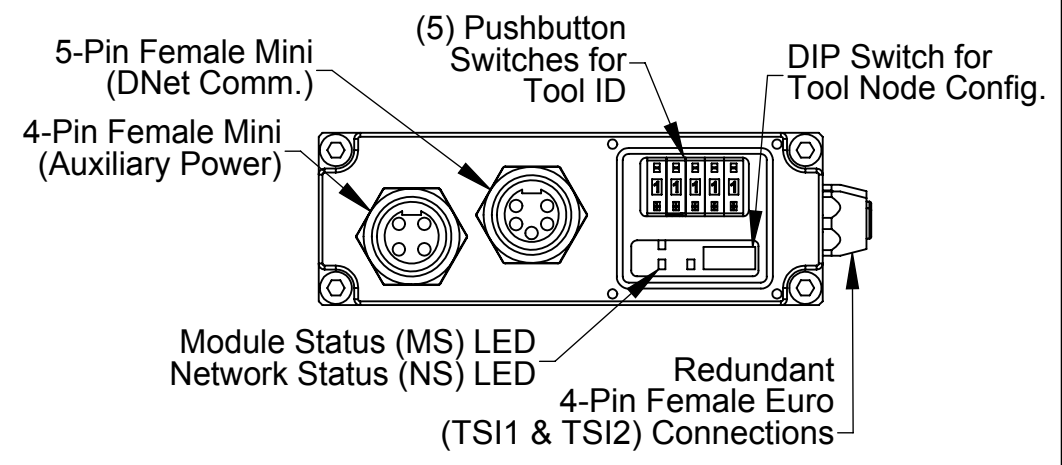
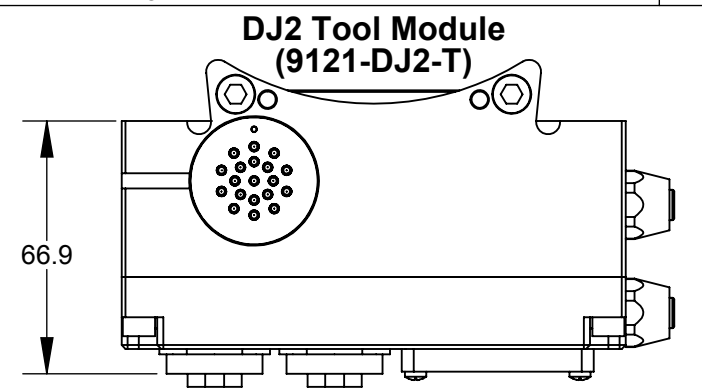
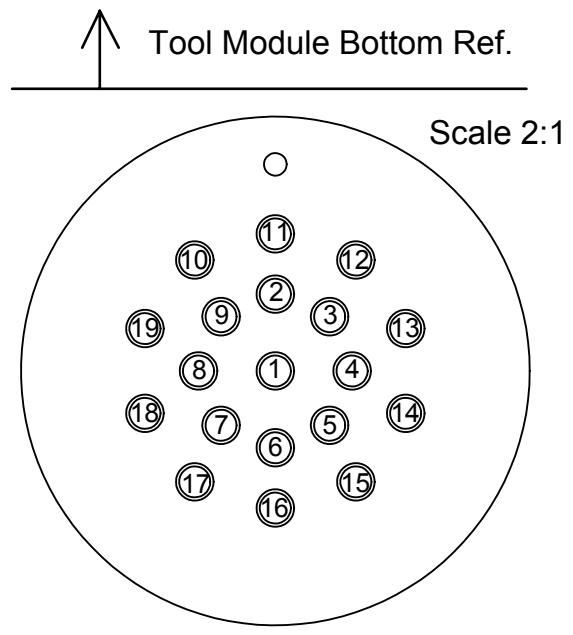

Mini Connector Wiring Info. Master/Tool			
4-Pin Connector		5-Pin Connector	
4-Pin	Description	5-Pin	Description
1	Aux V+	2	CAN V+
2	Spare 1	3	CAN V-
3	Spare 2	4	CAN_H
4	Aux V-	5	CAN_L

Euro Connector Wiring Info. (TSI Typical)	
4-Pin Euro Connector	Description
1	CAN V+
2	CAN V-
3	Relay Control
4	TSIV Input

NOTES: UNLESS OTHERWISE SPECIFIED  
DO NOT SCALE DRAWING. DRAWN IN SOLIDWORKS.  
ALL DIMENSIONS ARE IN MILLIMETERS.

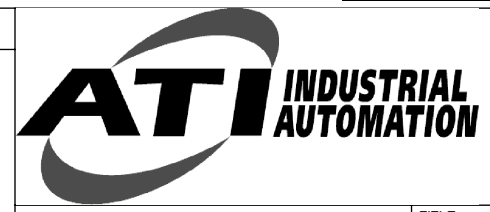

1031 Goodworth Drive, Apex, NC 27539, USA  
Tel: +1.919.772.0115 Email: info@ati-ia.com  
Fax: +1.919.772.8259 www.ati-ia.com  
ISO 9001 Registered Company

PROPERTY OF ATI INDUSTRIAL AUTOMATION, INC. NOT TO BE REPRODUCED IN ANY MANNER EXCEPT ON ORDER OR WITH PRIOR WRITTEN AUTHORIZATION OF ATI.

DRAWN BY: R. Heavner, 6/27/06		TITLE	
CHECKED BY: B. Digeso, 6/27/06		DJ3M DJ2T Module Drawing	
WEIGHT LBS: 3.21	SCALE 1:2	SIZE B	DRAWING NUMBER 9630-20-DJ3 DJ2
ASSEMBLY REF:	PRODUCT RELEASE # 051215-1	DATE:	REVISION 06
			SHEET 1 OF 3

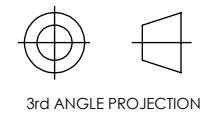

Rev.	Description	Initiator	Date
-	See Sheet 1	-	-

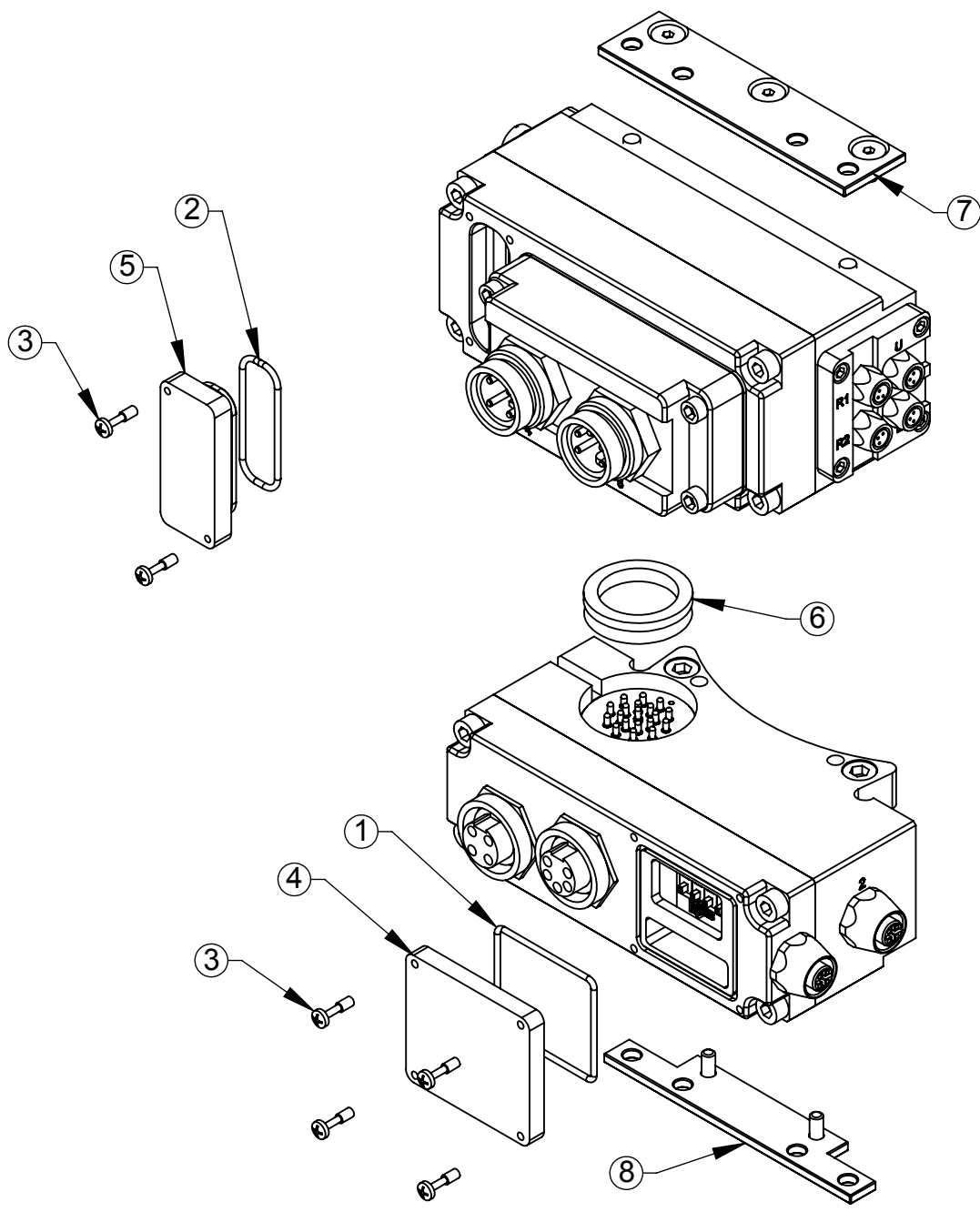
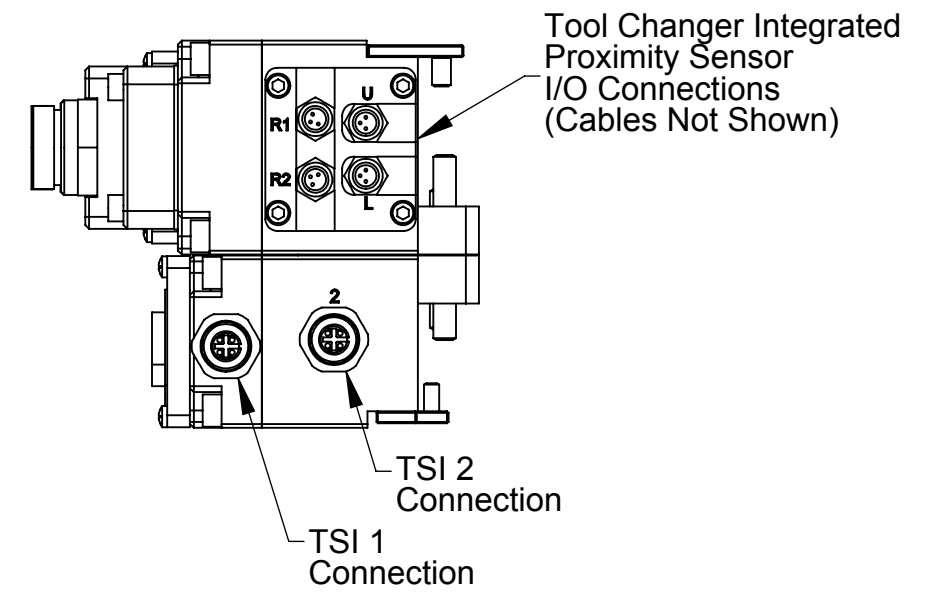
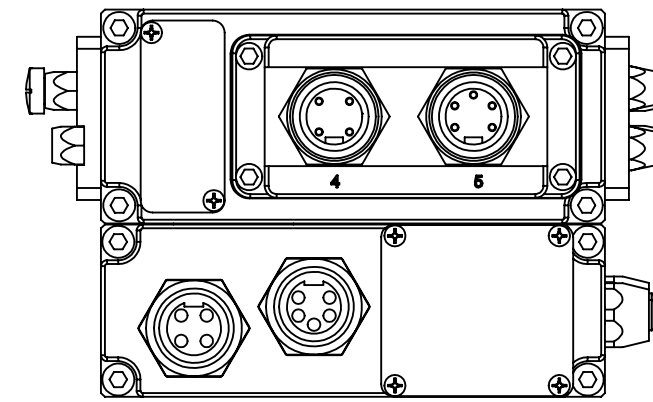
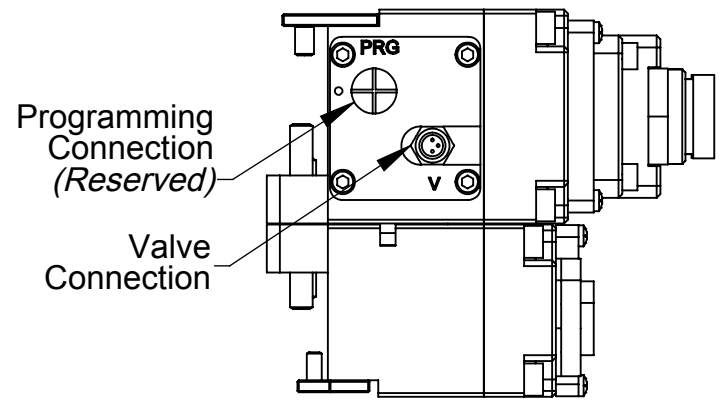

ITEM NO.	QTY.	PART NUMBER	DESCRIPTION
1	1	3410-0001021-01	O-RING AS568-031
5	1	3410-0001201-01	O-Ring, AS568-024
<b>DJ3-M/DJ2-T Serviceable Parts</b>			
3	1	3500-9957012-21	CAPTIVE SCREW M3 X 12 SLOTTED HEAD SS
4	1	3700-20-3058	Insta-Tool Window, Tool
5	1	3700-20-4820	Window, Master, DJ Module, Anular Seal
6	1	4010-0000030-01	V-Ring Seal
7	1	9005-20-1198	Master Cleat Assembly
8	1	9005-20-1199	Tool Cleat Assembly
35	1	3410-0001087-01	O-Ring 32mm X 1mm Buna
40	4	3500-1058016-11	M3 x 16mm SHCS Black Oxide
42	4	3515-9923037-30	1/4 OD x .140 ID x 3/8 Lg Nylon Spacer
78	2	3500-1066016-15A	M6 x 16mm SHCS Blue Dyed Magni ND Microspheres

NOTES: UNLESS OTHERWISE SPECIFIED  
DO NOT SCALE DRAWING. DRAWN IN SOLIDWORKS.  
ALL DIMENSIONS ARE IN MILLIMETERS.



1031 Goodworth Drive, Apex, NC 27539, USA  
Tel: +1.919.772.0115 Email: info@ati-ia.com  
Fax: +1.919.772.8259 www.ati-ia.com  
ISO 9001 Registered Company

PROPERTY OF ATI INDUSTRIAL AUTOMATION, INC. NOT TO BE REPRODUCED IN ANY MANNER EXCEPT ON ORDER OR WITH PRIOR WRITTEN AUTHORIZATION OF ATI.

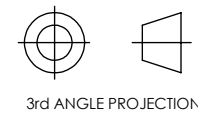

DRAWN BY: R. Heavner, 6/27/06		TITLE: DJ3M DJ2T Module Drawing	
CHECKED BY: B. Digeso, 6/27/06		SCALE: 1:2	SIZE: B
WEIGHT LBS: 3.21		DRAWING NUMBER: 9630-20-DJ3 DJ2	
ASSEMBLY REF:		REVISION: 06	DATE: 06
PRODUCT RELEASE # 051215-1		SHEET 2 OF 3	

Rev.	Description	Initiator	Date
-	See Sheet1	-	-

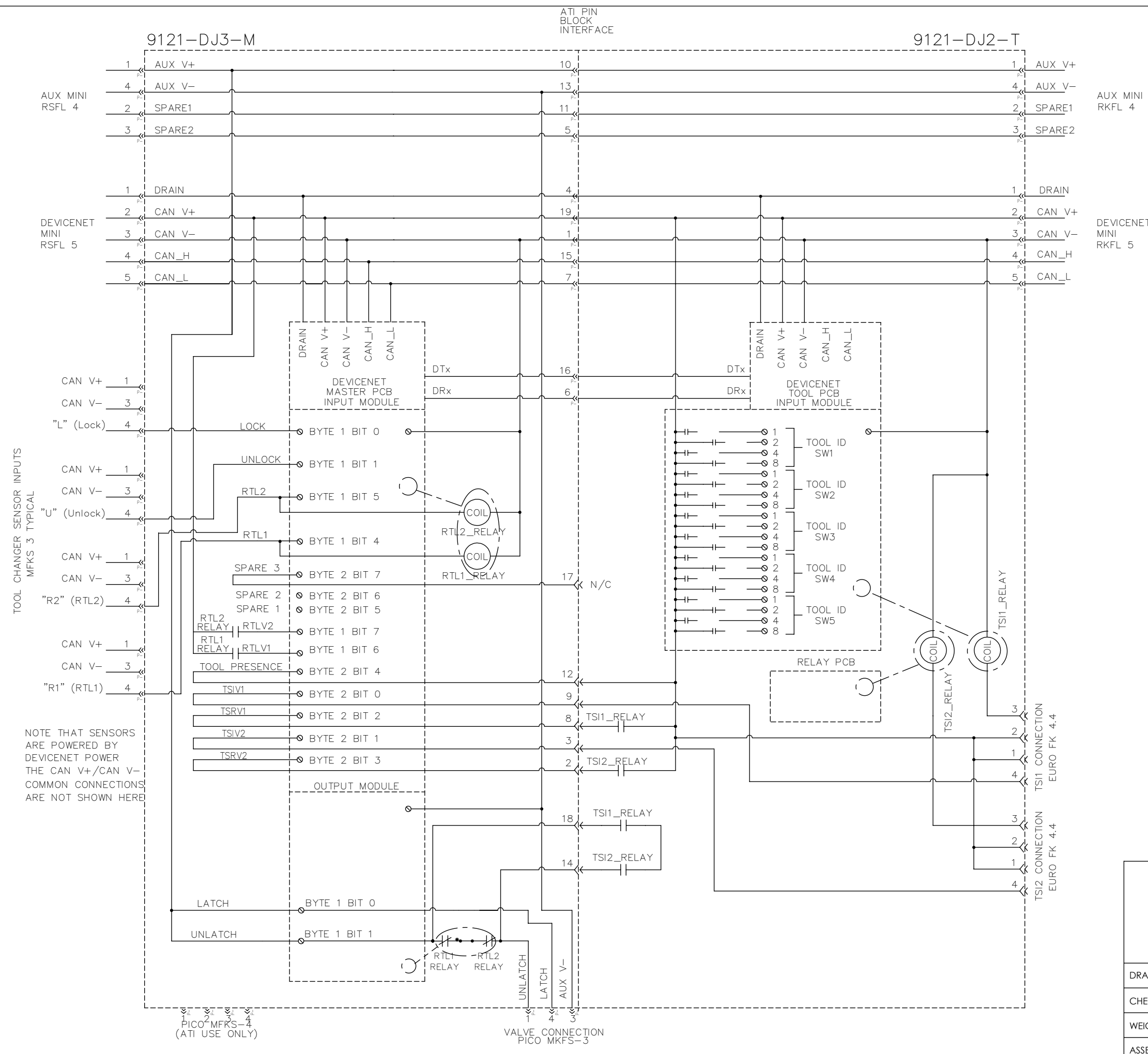

NOTES: UNLESS OTHERWISE SPECIFIED  
DO NOT SCALE DRAWING. DRAWN IN SOLIDWORKS. ALL DIMENSIONS ARE IN MILLIMETERS.

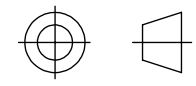
  
 3rd ANGLE PROJECTION

1031 Goodworth Drive, Apex, NC 27539, USA  
 Tel: +1.919.772.0115 Email: info@ati-ia.com  
 Fax: +1.919.772.8259 www.ati-ia.com  
 ISO 9001 Registered Company

PROPERTY OF ATI INDUSTRIAL AUTOMATION, INC. NOT TO BE REPRODUCED IN ANY MANNER EXCEPT ON ORDER OR WITH PRIOR WRITTEN AUTHORIZATION OF ATI.

DRAWN BY: R. Heavner, 6/27/06		TITLE DJ3M DJ2T Module Drawing	
CHECKED BY: B. Digeso, 6/27/06		SCALE 1:2	REVISION 06
WEIGHT LBS: 3.21	SIZE B	DRAWING NUMBER 9630-20-DJ3 DJ2	REVISION 06
ASSEMBLY REF:	PRODUCT RELEASE # 051215		SHEET 3 OF 3