

REV.	DESCRIPTION	INITIATOR	DATE
05	Eco 15800; Removed Tool Side Cleat Assembly 9005-20-1199.	CF	7/28/2017

Notes:

1. The modules are shown at sheet scale. All connector face views are shown at a 1:1 scale.
2. The 9121-DD2-T module supports the use of a mechanical limit switch for integration with the TSI feature.
3. Aux (4-Pin) and Bus (5-Pin) Mini Connectors are Oriented as Shown on the Modules.

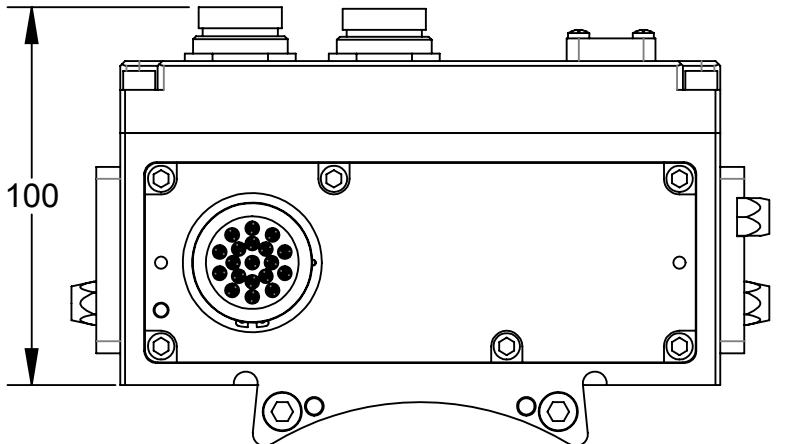
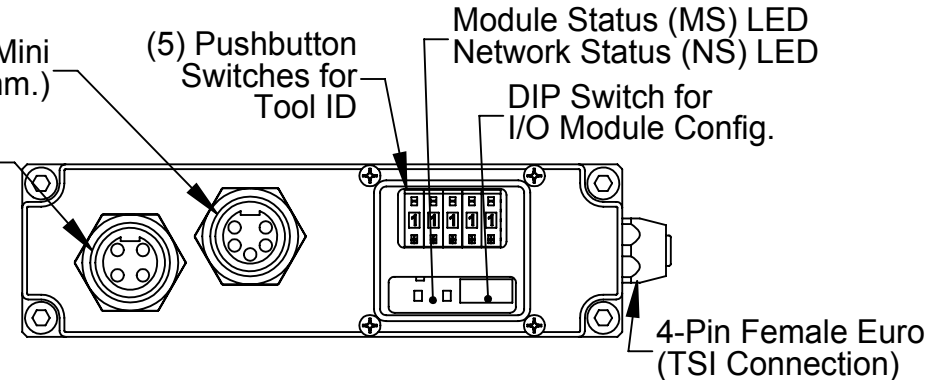
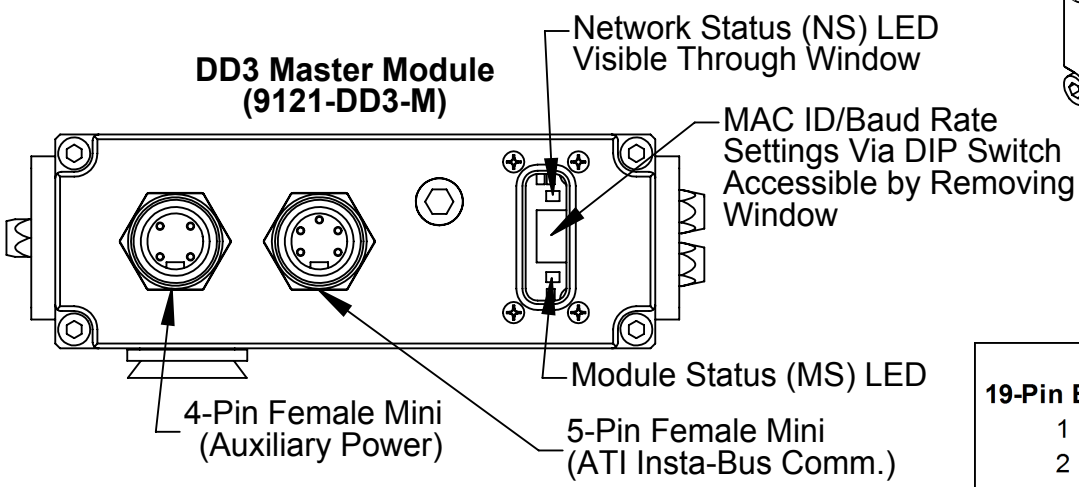
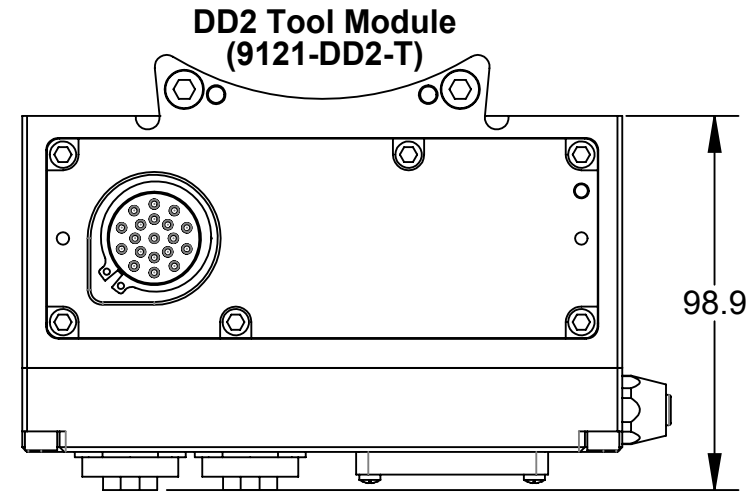
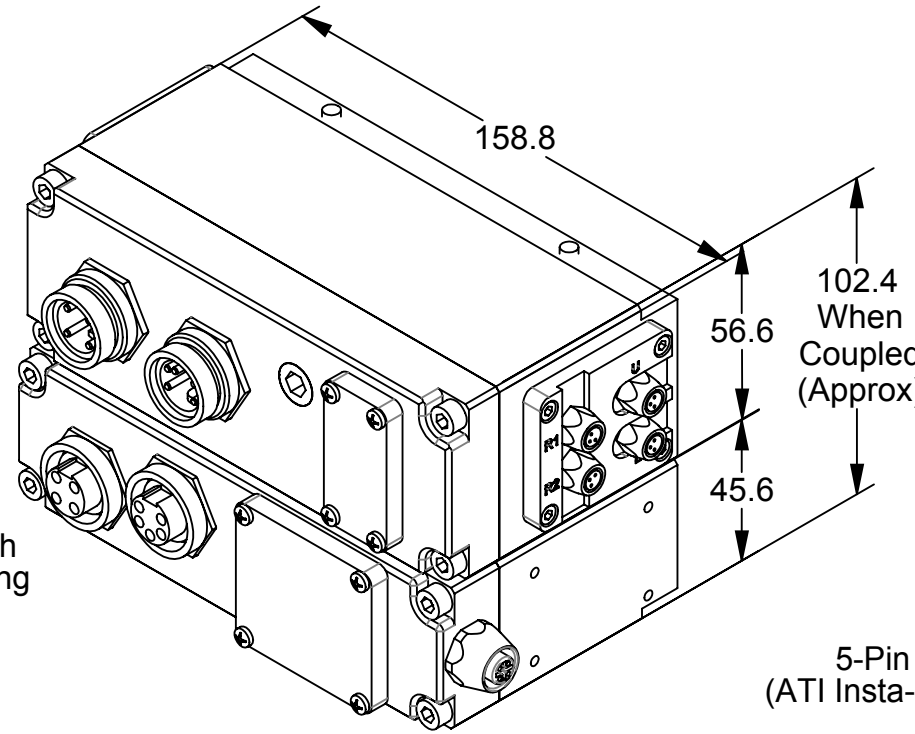

Description	
19-Pin Block (DD3-M/DD2-T)	
1	CAN V+
2	CAN V-
3	Spare
4	Aux V+
5	Spare
6	Aux V-
7	CAN_L / n/c
8	CAN_H / n/c
9	Drain
10	DG Grd
11	DTx
12	DRx
13	TSI In
14	TSI Out
15	TSIV
16	Tool Presence
17	n/c
18	n/c
19	n/c

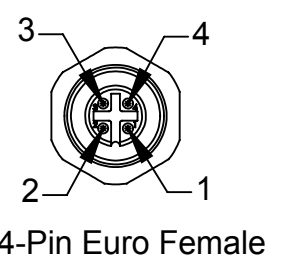
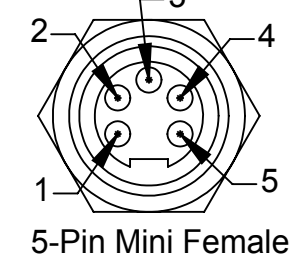
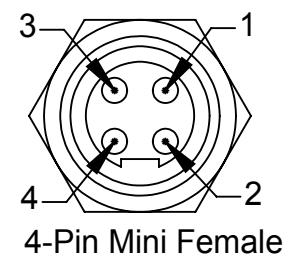
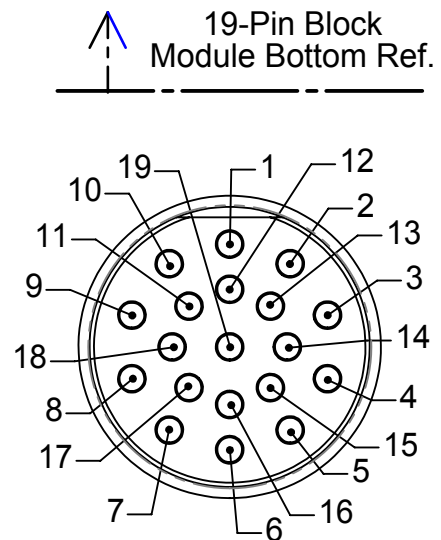

Mini Connector Wiring Info. Tool			
4-Pin Connector		5-Pin Connector	
Connector	Description	1	Description
1	Aux V+	2	CAN V+
2	Spare	3	CAN V-
3	Spare	4	ATI CAN_H
4	Aux V-	5	ATI CAN_L

Euro Connector Wiring Info.		
Description	4-Pin Euro Connector	
CAN V+	1	
CAN V-	2	
Relay Control	3	
TSIV Input	4	

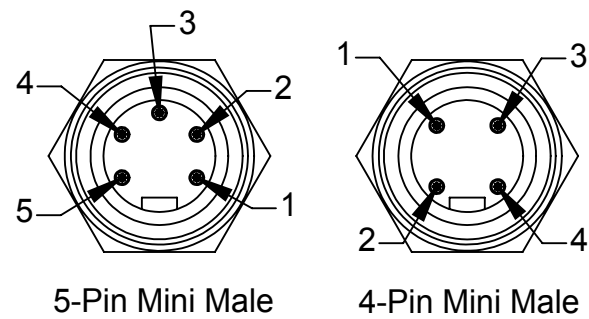

Standard Mini Connector Wiring Info.			
4-Pin Connector		5-Pin Connector	
Connector	Description	1	Description
1	Aux V+	2	CAN V+
2	Spare	3	CAN V-
3	Spare	4	CAN_H
4	Aux V-	5	CAN_L

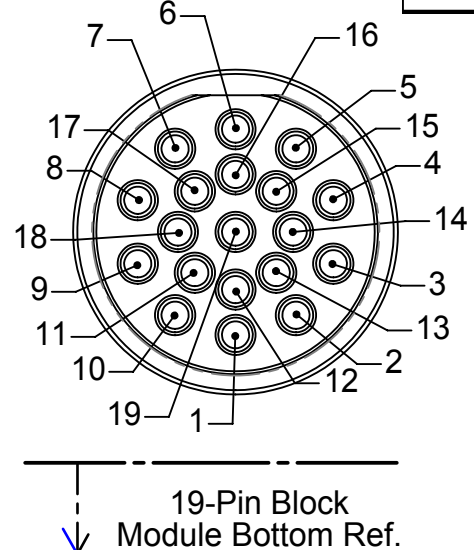

NOTES: UNLESS OTHERWISE SPECIFIED.

DO NOT SCALE DRAWING. ALL DIMENSIONS ARE IN MILLIMETERS.

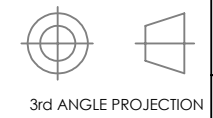

1031 Goodworth Drive, Apex, NC 27539, USA
 Tel: +1.919.772.0115 Email: info@ati-ia.com
 Fax: +1.919.772.8259 www.ati-ia.com
 ISO 9001 Registered Company

PROPERTY OF ATI INDUSTRIAL AUTOMATION, INC. NOT TO BE REPRODUCED IN ANY MANNER EXCEPT ON ORDER OR WITH PRIOR WRITTEN AUTHORIZATION OF ATI.

DRAWN BY: R.Heavner, 2/24/05		TITLE	
CHECKED BY: B. Digeso, 2/25/05		DD3-M DD2-T Insta-Tool Module Drawing	
PROJECT # 040611-1	SHEET 1 OF 2	SCALE 1:2	SIZE B
DRAWING NUMBER 9630-20-DD3M DD2T		REVISION 05	

Rev.	Description	Initiator	Date
	See Sheet 1 for Revision History		

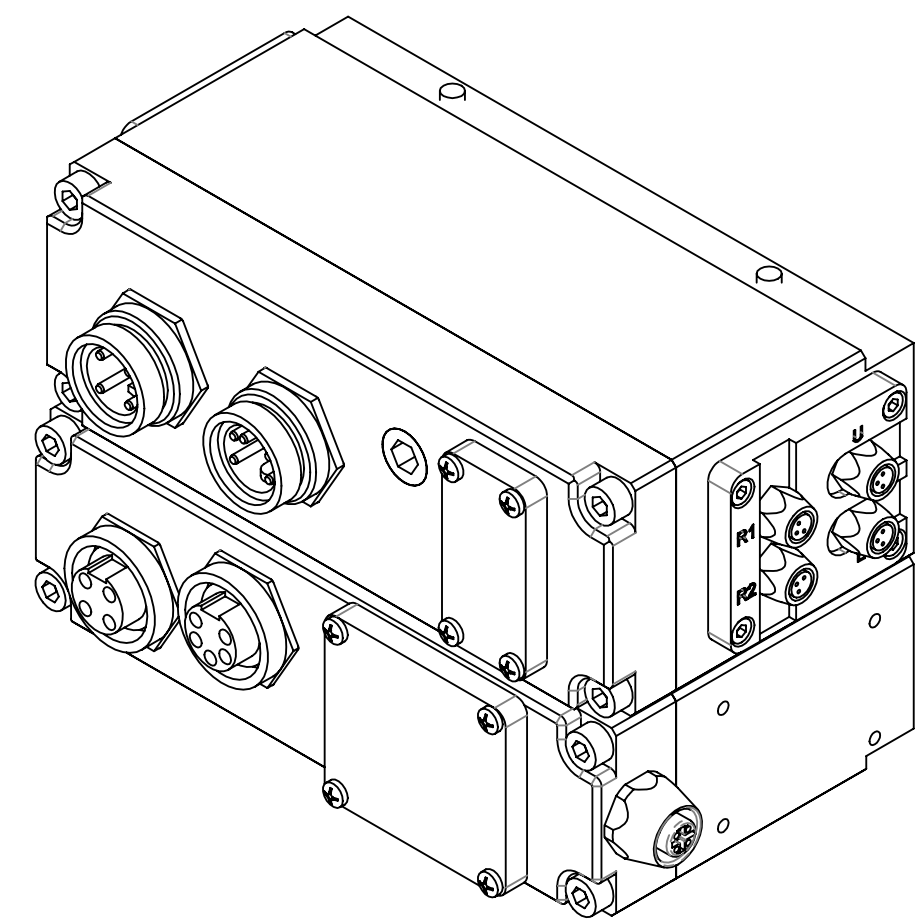
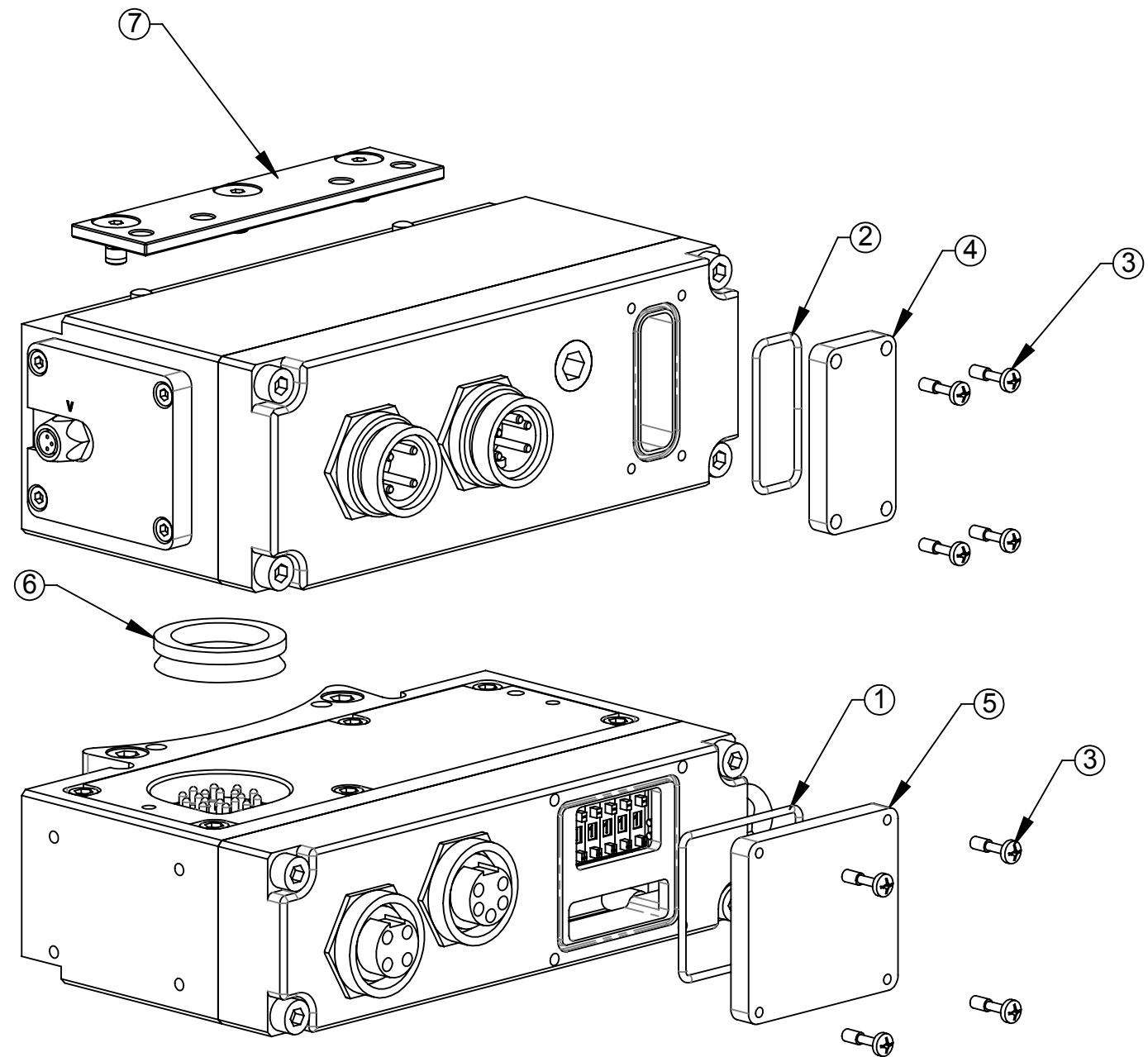

Spare Parts Bill of Materials

ITEM NO.	QTY.	PART NUMBER	DESCRIPTION
1	1	3410-0001021-01	O-RING AS568-031
2	1	3410-0001092-01	O-ring AS568-023
3	8	3500-9957012-21	CAPTIVE SCREW M3 X 12 SLOTTED HEAD SS
4	1	3700-20-2696	Thick Window for DP/DE45 Master
5	1	3700-20-3058	Insta-Tool Window, Tool
6	1	4010-0000030-01	V-Ring Seal
7	1	9005-20-1198	Master Cleat Sub-Assembly

NOTES: UNLESS OTHERWISE SPECIFIED.

DO NOT SCALE DRAWING. ALL DIMENSIONS ARE IN MILLIMETERS.

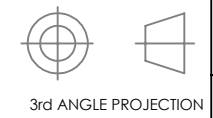

1031 Goodworth Drive, Apex, NC 27539, USA
 Tel: +1.919.772.0115 Email: info@ati-ia.com
 Fax: +1.919.772.8259 www.ati-ia.com
 ISO 9001 Registered Company

PROPERTY OF ATI INDUSTRIAL AUTOMATION, INC. NOT TO BE REPRODUCED IN ANY MANNER EXCEPT ON ORDER OR WITH PRIOR WRITTEN AUTHORIZATION OF ATI.

DRAWN BY: R.Heavner, 2/24/05		TITLE	
CHECKED BY: B. Digeso, 2/25/05		DD3-M DD2-T Insta-Tool Module Drawing	
PROJECT #	040611-1	SHEET	2 OF 2
SCALE	1:1.5	SIZE	B
DRAWING NUMBER	9630-20-DD3M DD2T		REVISION
			05