

REV.	DESCRIPTION	INITIATOR	DATE
10	ECO 20127; Replaced 3700-20-5621 with 3700-20-11570 Tool ID window.	TJM	12/20/2021

9120-CV14PWx-M

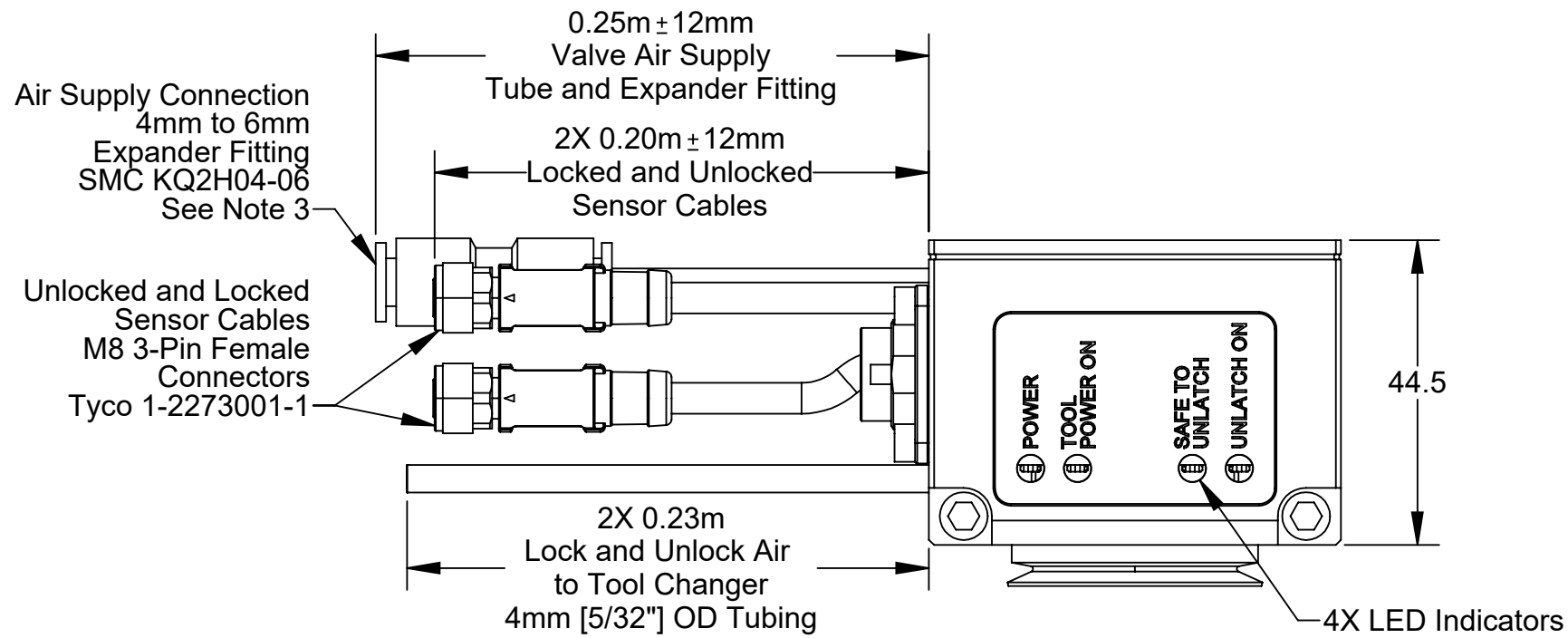

9120-CV10P-T

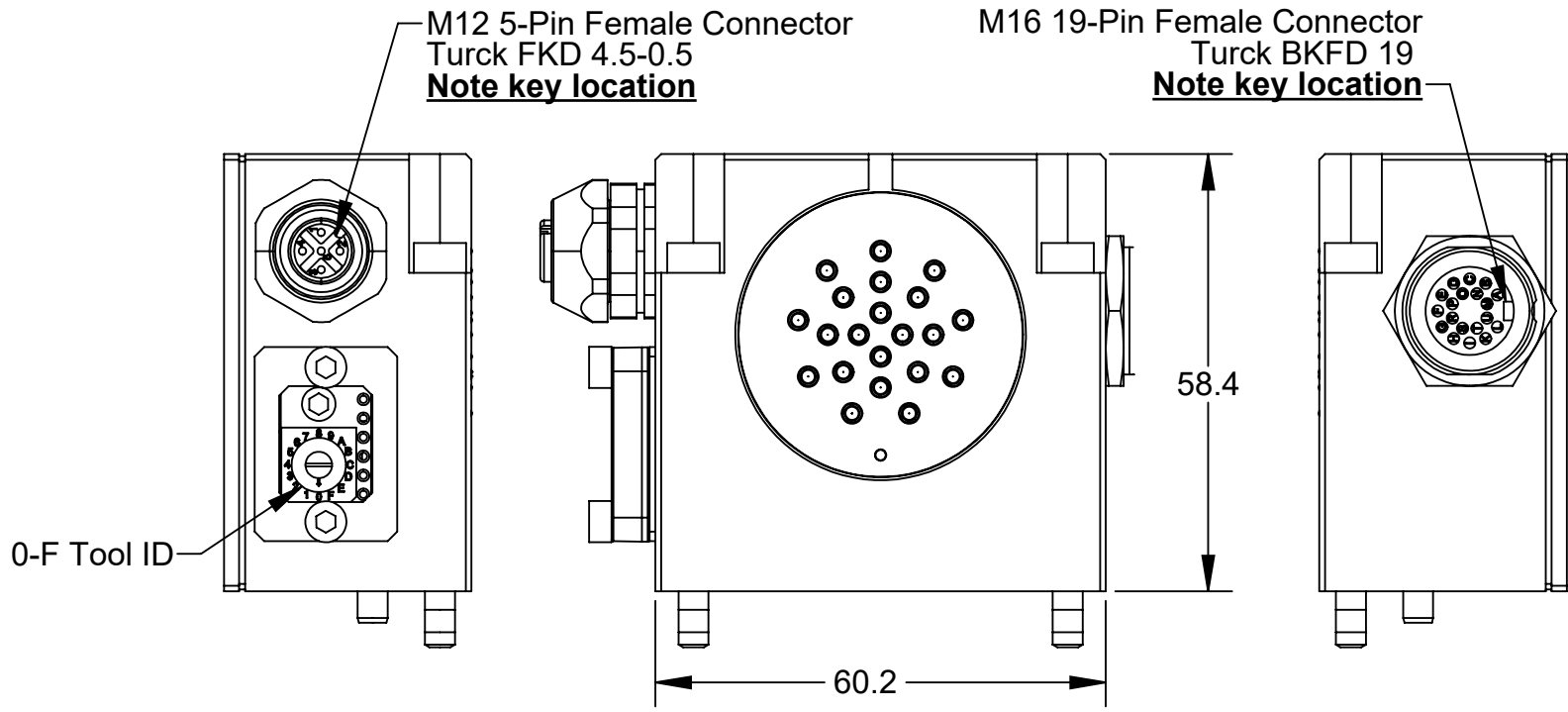
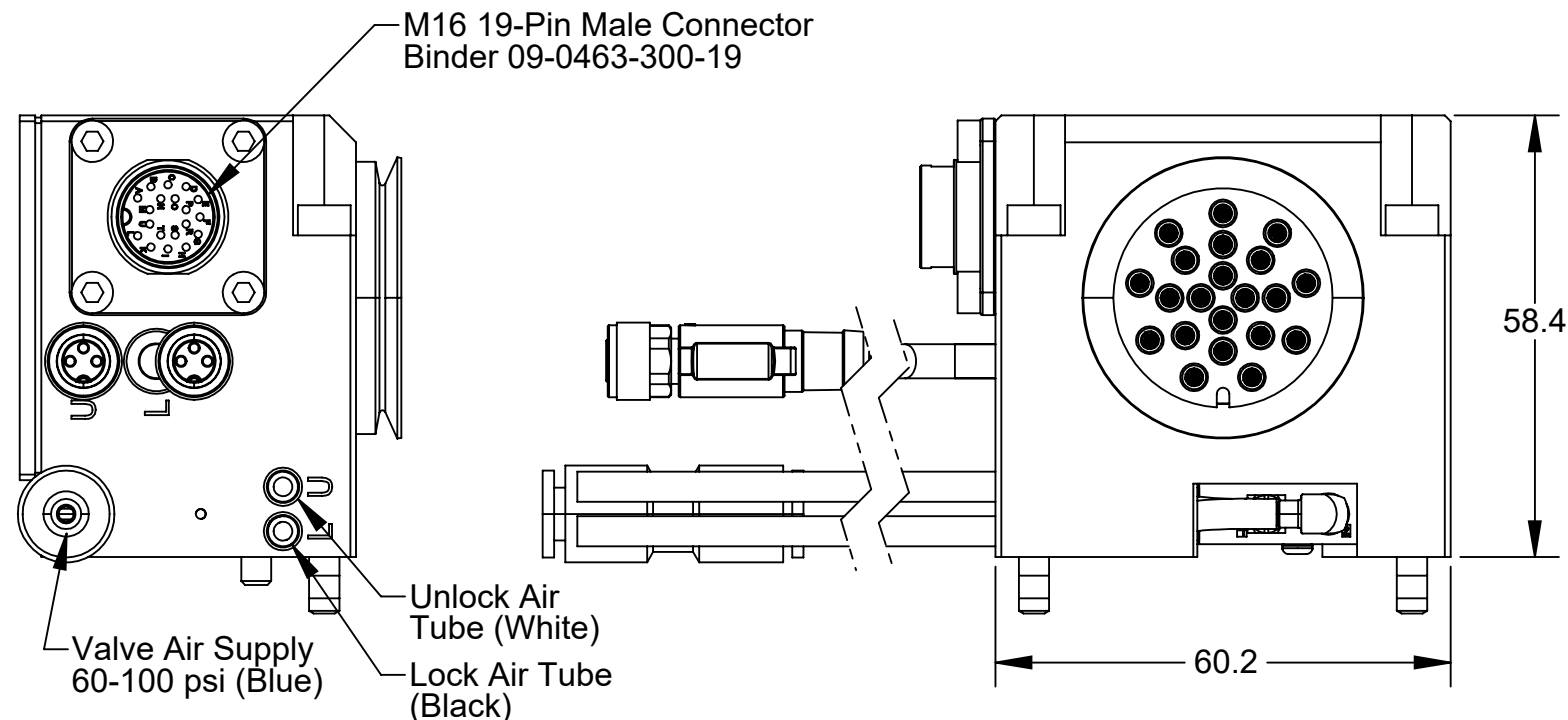
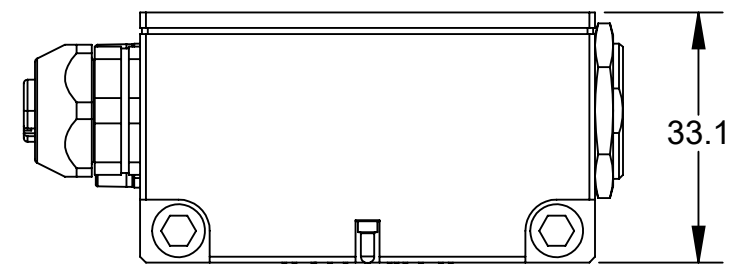

- Notes:**
- The CV14PWx-M family of Master modules have straight Locked and Unlocked sensor connectors and are designed to work with PNP sensors and PNP unlatch output.
 - The CV14PWx-M family of modules include 1X Lock and 1X Unlock port fittings. The type of pneumatic fittings included with the module is designated by the module part number as follows:
 - 9120-CV14PWN-M = 1/8 NPT Fittings
 - 9120-CV14PWE-M = 1/8 BSPP Fittings
 - 9120-CV14PWR-M = 1/8 BSPT Fittings
 Note: Fittings are not shown in this drawing.
 - The Tool Changer air supply is connected to the module via a 4mm-to-6mm expander fitting and 4mm [5/32"] OD tubing.
 - Connector pin-outs are on Sheet 2.
 - Electrical Schematic is on Sheet 3.
 - Electrical Schematic Notes are on Sheet 4.

NOTES: UNLESS OTHERWISE SPECIFIED.		 <p>1031 Goodworth Drive, Apex, NC 27539, USA Tel: +1.919.772.0115 www.ati-ia.com Fax: +1.919.772.8259 ISO 9001 Registered Company</p> <p>PROPERTY OF ATI INDUSTRIAL AUTOMATION, INC. NOT TO BE REPRODUCED IN ANY MANNER EXCEPT ON ORDER OR WITH PRIOR WRITTEN AUTHORIZATION OF ATI.</p>	
DO NOT SCALE DRAWING. ALL DIMENSIONS ARE IN MILLIMETERS.			
DRAWN BY: W. Berrocal		TITLE: CV14PWx Master CV10P Tool Customer Drawing	
CHECKED BY: A. Strotzer, 7/14/19			
PROJECT # 190203-1 SHEET 1 OF 4		SCALE: 1:1	SIZE: B
		DRAWING NUMBER: 9630-20-CV14PWxM CV10PT	REVISION: 10

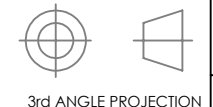

Notes:

- 1. WARNING: Tool Release Will Occur with actuation of the Unlatch Valve Manual Override. Use of the valve manual override is restricted to contingency situations. The tool changer and associated tool should be in a stand or storage location prior to actuation of the manual override.**
- 2. NOTICE: Actuation of valve override buttons requires very little travel (~1mm) and only a small amount of force. Applying excess force can damage the solenoid or cause override button to stick in one position. Use non-sharp object, similar to ball nose 1.3mm Allen key, to gently depress the override button.**

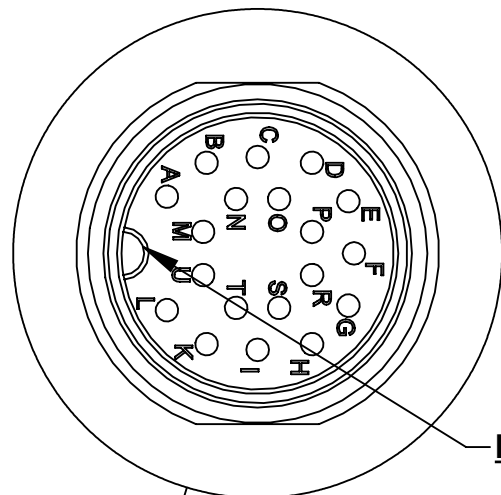

Note key orientation

DETAIL B
SCALE 3 : 1

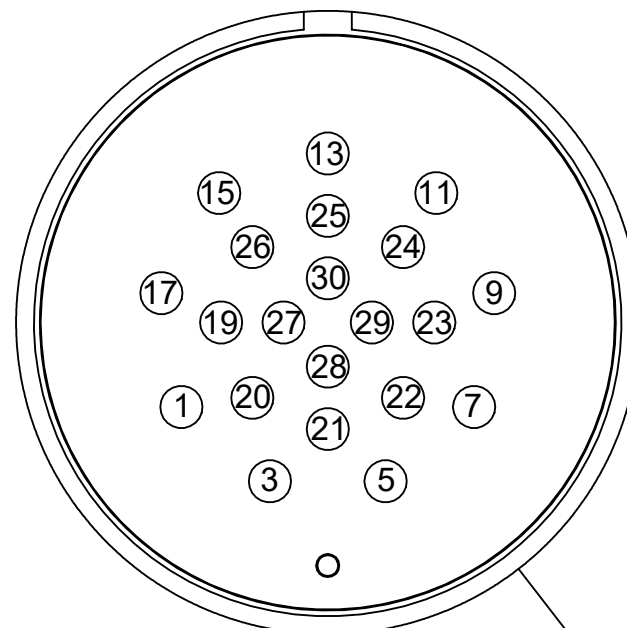

Note key orientation

DETAIL C
SCALE 2 : 1

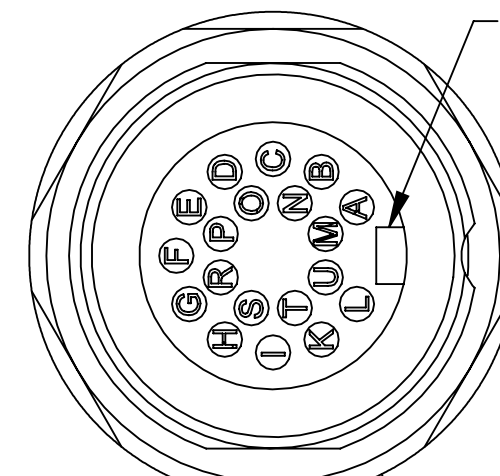

DETAIL E
SCALE 3 : 1

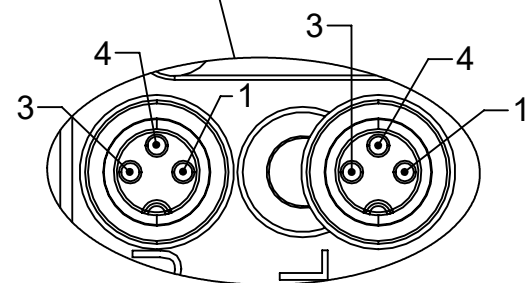
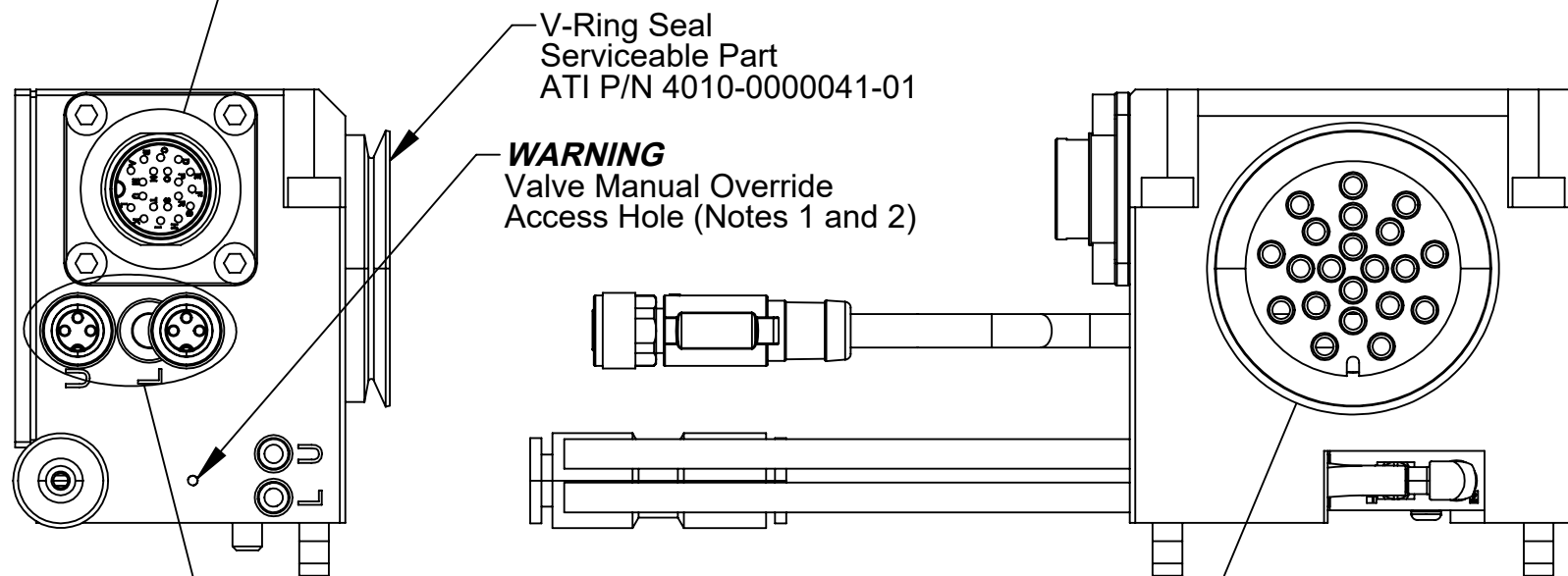

DETAIL F
SCALE 2 : 1

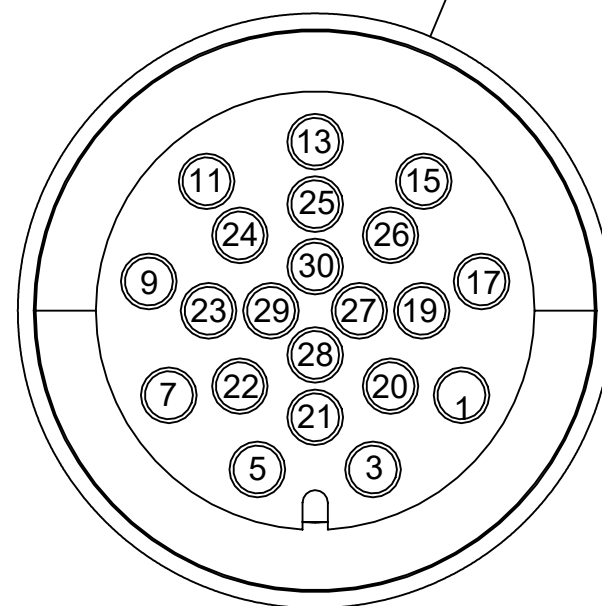

DETAIL A
SCALE 2 : 1

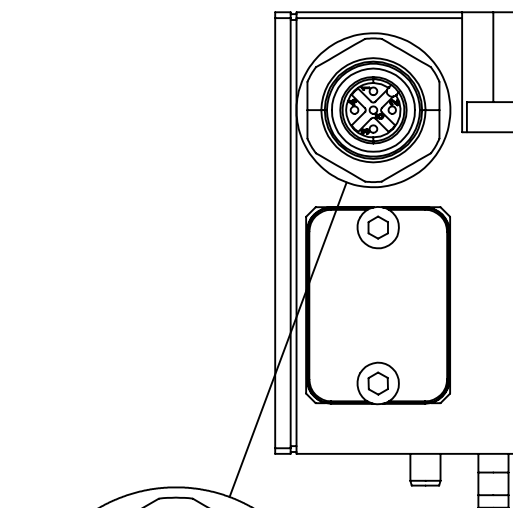

DETAIL D
SCALE 2 : 1

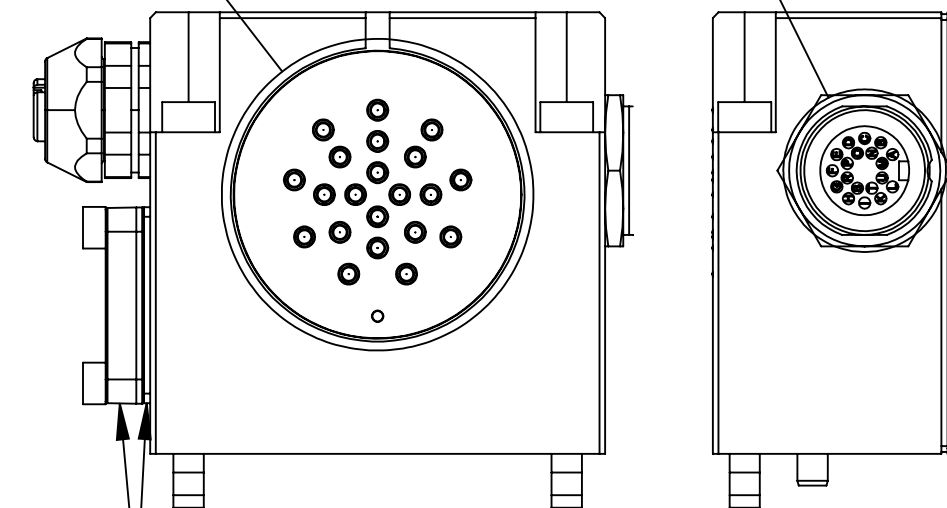

Tool ID Window and Gasket
Serviceable Parts
ATI P/N 3700-20-11570 and 3700-20-5622

NOTES: UNLESS OTHERWISE SPECIFIED.

DO NOT SCALE DRAWING. ALL DIMENSIONS ARE IN MILLIMETERS.

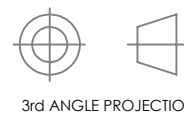

1031 Goodworth Drive, Apex, NC 27539, USA
Tel: +1.919.772.0115 www.ati-ia.com
Fax: +1.919.772.8259 ISO 9001 Registered Company

PROPERTY OF ATI INDUSTRIAL AUTOMATION, INC. NOT TO BE REPRODUCED IN ANY MANNER EXCEPT ON ORDER OR WITH PRIOR WRITTEN AUTHORIZATION OF ATI.

DRAWN BY: W. Berrocal		TITLE	
CHECKED BY: A. Strotzer, 7/14/19		CV14PWx Master CV10P Tool Customer Drawing	
PROJECT # 190203-1	SHEET 2 OF 4	SCALE 1:1	SIZE B
DRAWING NUMBER 9630-20-CV14PWxM CV10PT		REVISION 10	

9120-CV14PWx-M

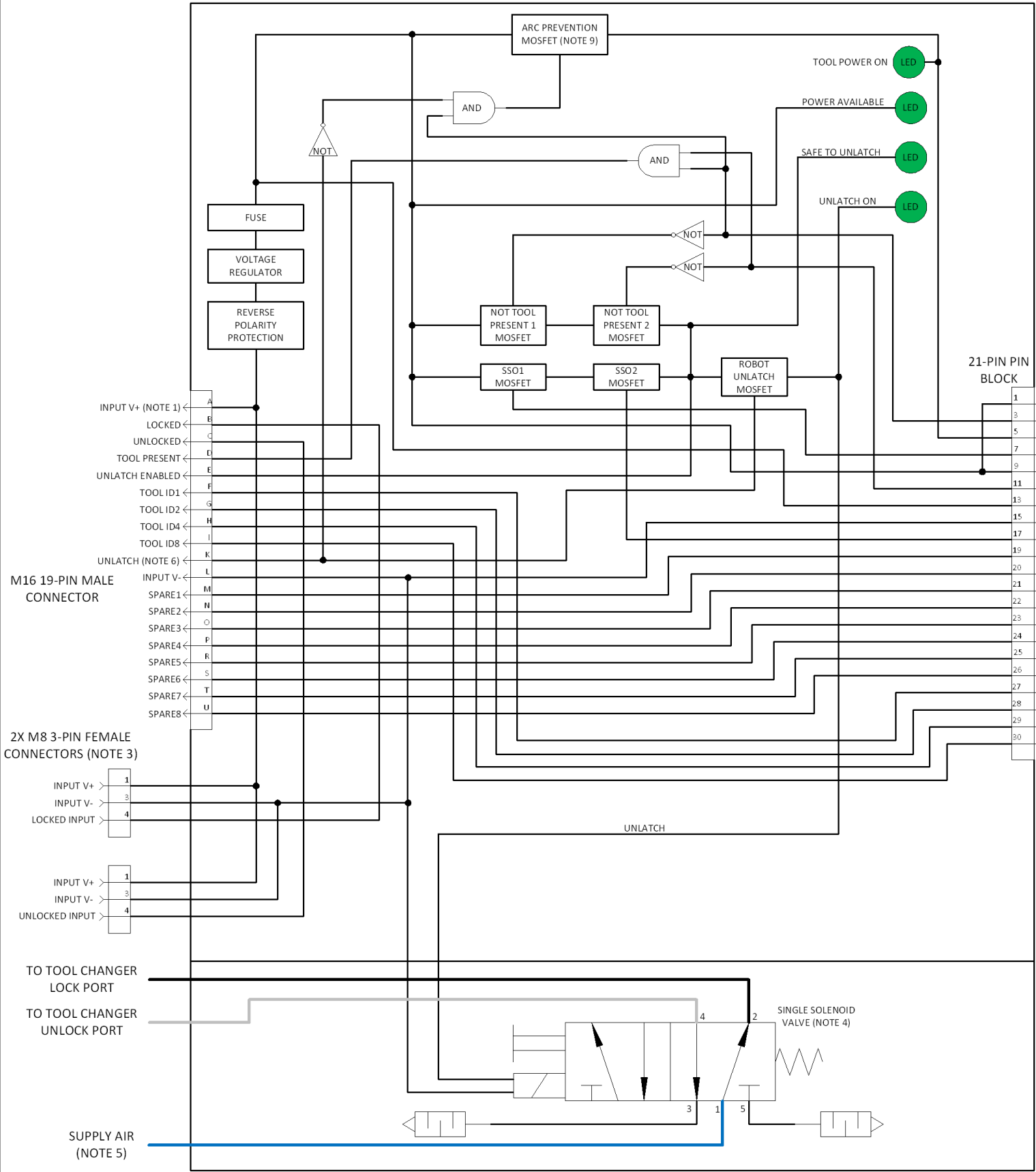

9120-CV10P-T

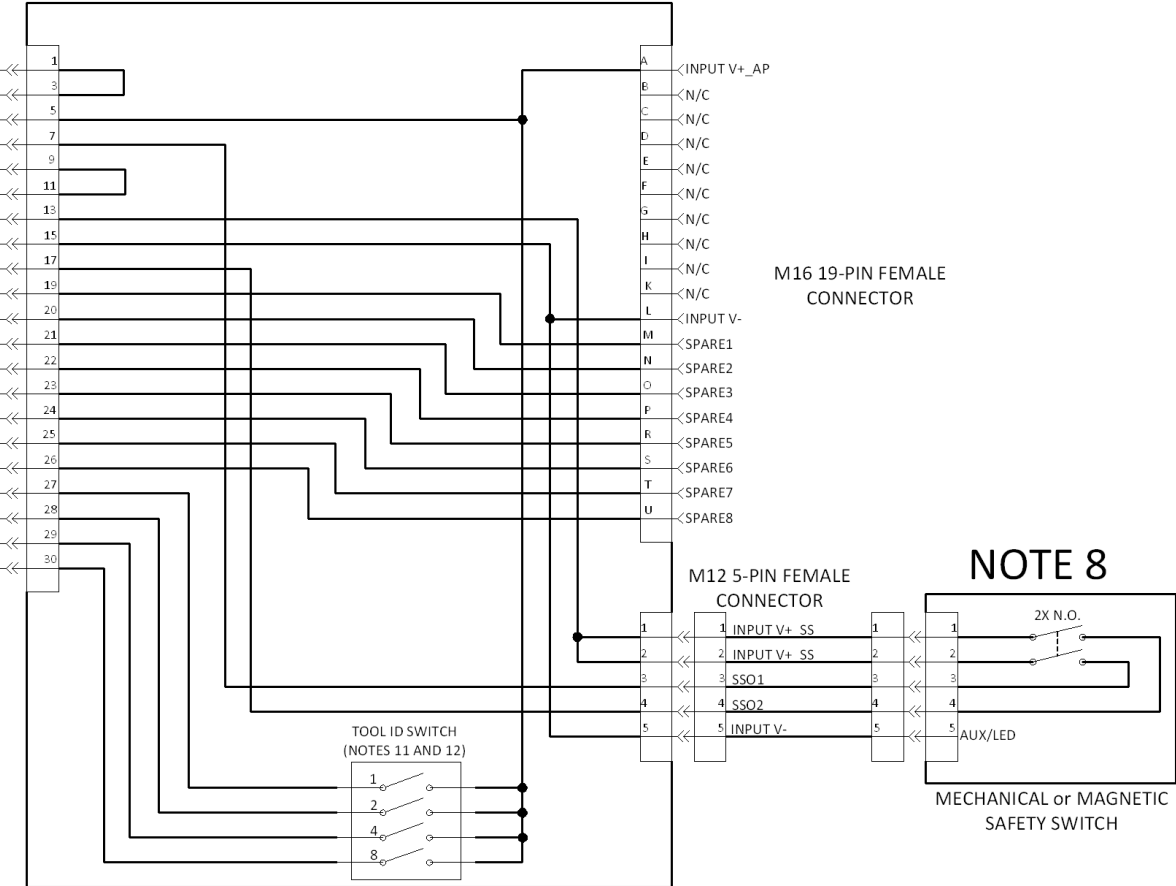

Notes:
1. Electrical Schematic notes are on Sheet 4.

NOTES: UNLESS OTHERWISE SPECIFIED.
DO NOT SCALE DRAWING. ALL DIMENSIONS ARE IN MILLIMETERS.



1031 Goodworth Drive, Apex, NC 27539, USA
Tel: +1.919.772.0115 www.ati-ia.com
Fax: +1.919.772.8259 ISO 9001 Registered Company

PROPERTY OF ATI INDUSTRIAL AUTOMATION, INC. NOT TO BE REPRODUCED IN ANY MANNER EXCEPT ON ORDER OR WITH PRIOR WRITTEN AUTHORIZATION OF ATI.

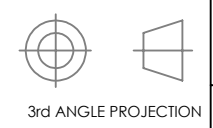

DRAWN BY: W. Berrocal		TITLE	
CHECKED BY: A. Strotzer, 7/14/19		CV14PWx Master CV10P Tool Customer Drawing	
PROJECT # 190203-1	SHEET 3 OF 4	SCALE 1:1	SIZE B
DRAWING NUMBER 9630-20-CV14PWxM CV10PT		REVISION 10	

Notes:

1. Input current (Pin A of the M16 connector) is limited to 4A. Input voltage is limited to 24V +20%/-10%.
2. Current and voltage on Spare Signals 1-8 are limited to 4A, 50V.
3. The CV14PWx Master module is designed to work with PNP Locked and Unlocked sensors and a PNP unlatch output. The Unlatch Enabled and Tool Present inputs are also also PNP. Note: The Locked and Unlocked sensors are supplied with the Tool Changer.
4. The CV14PWx Master module is equipped with a single solenoid 5-port, 2-position valve with spring return. The valve's purpose is to lock and unlock the Tool Changer. Because this is a single solenoid valve, the valve will default to the lock state when electrical power is lost.
5. The valve must be supplied with clean, dry air filtered to 40 microns. The air supply pressure must be between 60 and 100 psi [.41 MPa to .69 MPa]. A 6mm to 4mm reducer fitting is attached to the end of the valve air supply fitting.
6. The CV14PWx Master module is designed to prevent an accidental tool unlatch. The unlatch command will only be executed if the Safety Switch inputs, SSO1 and SSO2, are both true, indicating that the Tool is in the Tool Stand.
7. The CV14PW Master is equipped with a bypass circuit that will allow an unlatch command to be executed when NO TOOL is present, as indicated by the two Tool Present signals.
8. Use a safety rated mechanical or magnetic limit switch with two Normally Open contacts. The contacts should only close when the Tool is nested safely in the Tool Stand. The switch must be connected as indicated in the schematic.
9. The CV14PW Master is equipped with Arc Prevention circuitry that protects the electrical contacts against arcing when coupling and uncoupling. The Arc Prevention circuit will turn power on when Unlatch is true and the Tool Present 1 signal is true.
10. The CV14PW Master is equipped with four LEDs indicating the following:
 1. "POWER": Power to the Master is available
 2. "TOOL POWER ON": Arc prevention has turned on power to the Tool
 3. "SAFE TO UNLATCH": The conditions for a safe unlatch have been met
 4. "UNLATCH ON": The unlatch output to the valve is active
11. Table 1 shows a detailed pinout of the Master side M16 Male Connector.
12. The Tool ID circuit is rated to 30V, 100mA. See Table 2 for Tool ID binary output. The Tool ID common is Input V+.

TABLE 1: MASTER SIDE M16 19-PIN CONNECTOR PINOUT

Connector Pin	Signal Name
A	Input V+ (24V)
B	Locked
C	Unlocked
D	Tool Present
E	Unlatch Enabled
F	Tool ID1
G	Tool ID2
H	Tool ID4
I	Tool ID8
K	Unlatch
L	Input V- (0V)
M	Spare 1
N	Spare 2
O	Spare 3
P	Spare 4
R	Spare 5
S	Spare 6
T	Spare 7
U	Spare 8

TABLE 2: TOOL ID BINARY OUTPUT

Switch Selection	Pin	Pin	Pin	Pin
	I	H	G	F
0	0	0	0	0
1	0	0	0	1
2	0	0	1	0
3	0	0	1	1
4	0	1	0	0
5	0	1	0	1
6	0	1	1	0
7	0	1	1	1
8	1	0	0	0
9	1	0	0	1
A	1	0	1	0
B	1	0	1	1
C	1	1	0	0
D	1	1	0	1
E	1	1	1	0
F	1	1	1	1

NOTES: UNLESS OTHERWISE SPECIFIED.

DO NOT SCALE DRAWING. ALL DIMENSIONS ARE IN MILLIMETERS.



3rd ANGLE PROJECTION



1031 Goodworth Drive, Apex, NC 27539, USA
 Tel: +1.919.772.0115 www.ati-ia.com
 Fax: +1.919.772.8259 ISO 9001 Registered Company

PROPERTY OF ATI INDUSTRIAL AUTOMATION, INC. NOT TO BE REPRODUCED IN ANY MANNER EXCEPT ON ORDER OR WITH PRIOR WRITTEN AUTHORIZATION OF ATI.

DRAWN BY: W. Berrocal		TITLE		
CHECKED BY: A. Strotzer, 7/14/19		CV14PWx Master CV10P Tool Customer Drawing		
PROJECT # 190203-1	SHEET 4 OF 4	SCALE	SIZE	DRAWING NUMBER
		1:1	B	9630-20-CV14PWxM CV10PT
				REVISION
				10