

Rev.	Description	Initiator	Date
08	ECO 13199; Removed 9005-20-1198 & 9005-20-1199 Cleat assemblies representations from drawing; Corrected various Kit & Serviceable Parts number note errors; Corrected right side view with updated dim's.	TBC	3/24/2015

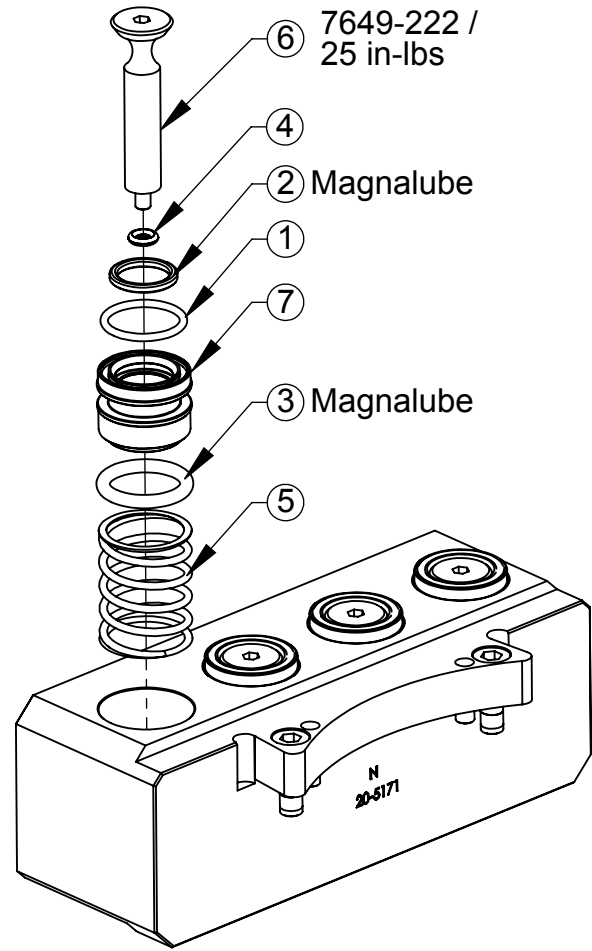
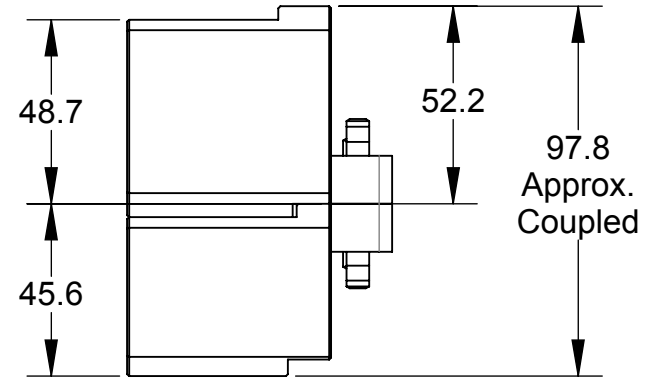
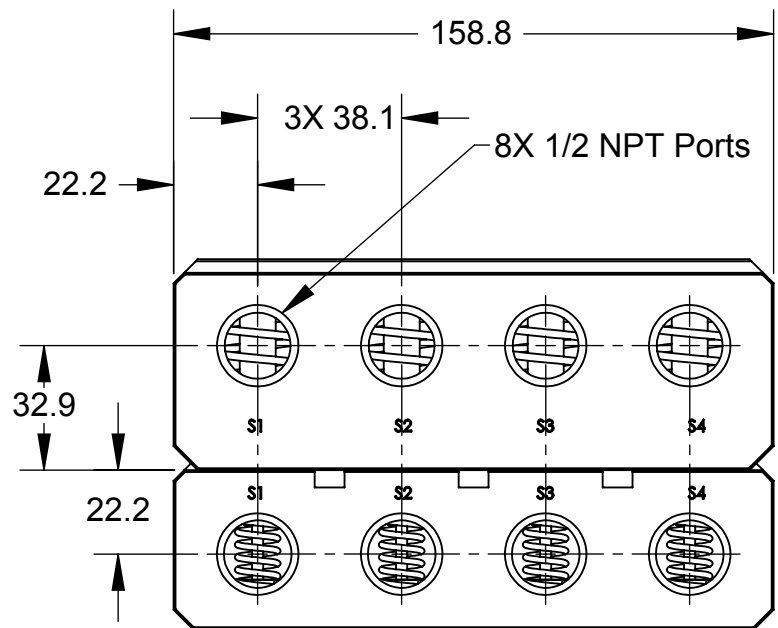

Notes:

Materials of Construction:

1. Housings - Aluminum
2. Valve Components - Stainless Steel, Bronze & Nitrile

Operations:

1. For best results ensure fluids are near neutral pH, minimize fluid particulate size and keep fluid module mating surfaces free and clear of any debris.
2. Checked ports can produce significant forces when under high supply pressures. See product manual regarding proper operating procedure.

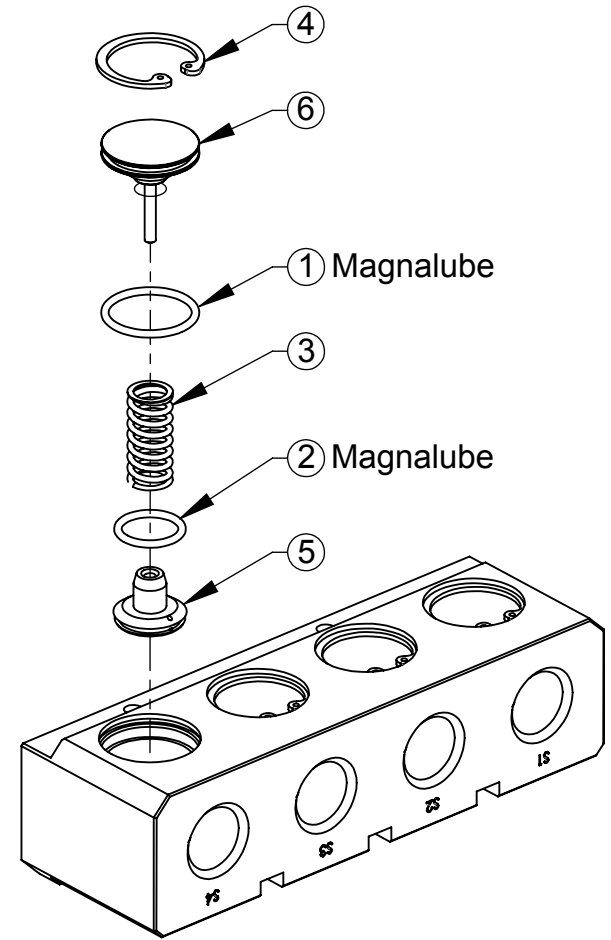

ITEM NO.	QTY	PART NUMBER	DESCRIPTION
1	4	3410-0001244-01	O-Ring, 19x2
2	4	3410-0001268-01	O-Ring 14MM X 2MM Buna 90A
3	4	3410-0001366-01	O-Ring, AS568-210, N1090 (ELF), D85
4	4	3410-0001371-01	O-Ring, 4mm ID x 2mm, Buna-N, D70
5	4	3610-7504501-21	SPRING, 1/2" F/A MASTER
6	4	3700-20-4616	Fluid Module Valve, 1/2, Master
7	4	3700-20-7621	Fluid Module Poppet, Relieved, 1/2, Master

ITEM NO.	QTY	PART NUMBER	DESCRIPTION
1	4	3410-0001243-01	O-Ring, 22x2
2	4	3410-0001269-01	O-Ring, 15x2, D90
3	4	3610-6203201-21	SPRING, 1/2" F/A TOOL
4	4	3690-2000002-11	RETAINING RING, INTERNAL, 1-1/16"
5	4	3700-20-4621	Fluid Module Valve, 1/2, Tool
6	4	9005-20-1831	1/2" Port Plug Assembly, Tool

Note: Service Kit 9005-20-1322 consists of (1) each of Items 1 & 2.
Service Kit 9005-20-1421 consists of (1) each of Items 1 thru 6.

Note: Service Kit 9005-20-1321 consists of (1) each of Items 1,2,3, & 4.
Service Kit 9005-20-1420 consists of (1) each of Items 1 thru 7

NOTES: UNLESS OTHERWISE SPECIFIED.

DO NOT SCALE DRAWING. ALL DIMENSIONS ARE IN MILLIMETERS.

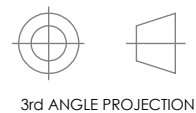

1031 Goodworth Drive, Apex, NC 27539, USA
Tel: +1.919.772.0115 Email: info@ati-ia.com
Fax: +1.919.772.8259 www.ati-ia.com
ISO 9001 Registered Company

PROPERTY OF ATI INDUSTRIAL AUTOMATION, INC. NOT TO BE REPRODUCED IN ANY MANNER EXCEPT ON ORDER OR WITH PRIOR WRITTEN AUTHORIZATION OF ATI.

DRAWN BY: D. Wagner, 3/26/07		TITLE	
CHECKED BY: DKL, 3/29/07		AP2-M, AP2-T Module Drawing	
PROJECT #	070206-5	SHEET	1 OF 1
SCALE	1:2	SIZE	B
DRAWING NUMBER	9630-20-AP2	REVISION	08