

Rev.	Description	Initiator	Date
01	INITIAL DRAWING	KRZ	09/17/15

**MASTER MODULE  
(9121-AD6-M)**

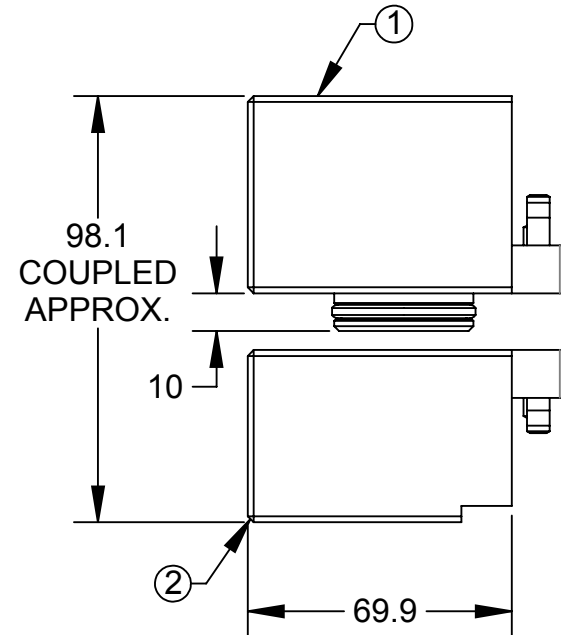

**TOOL MODULE  
(9121-AD6-T)**

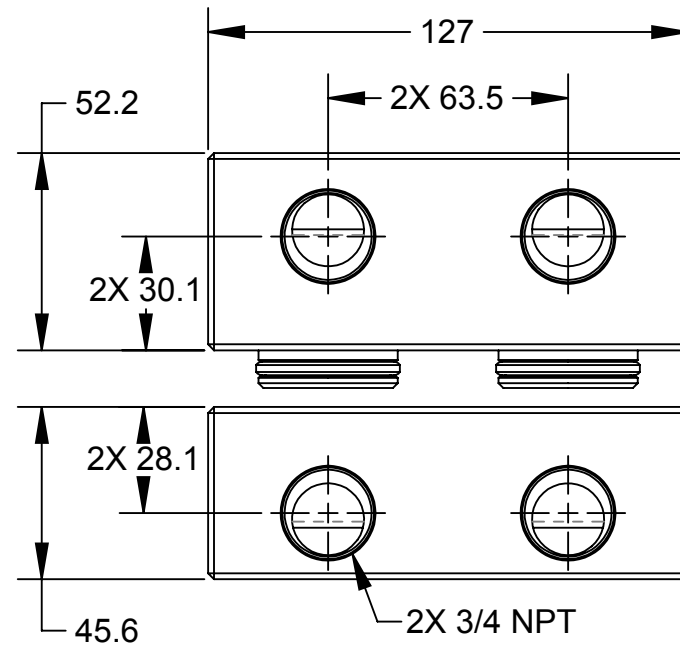
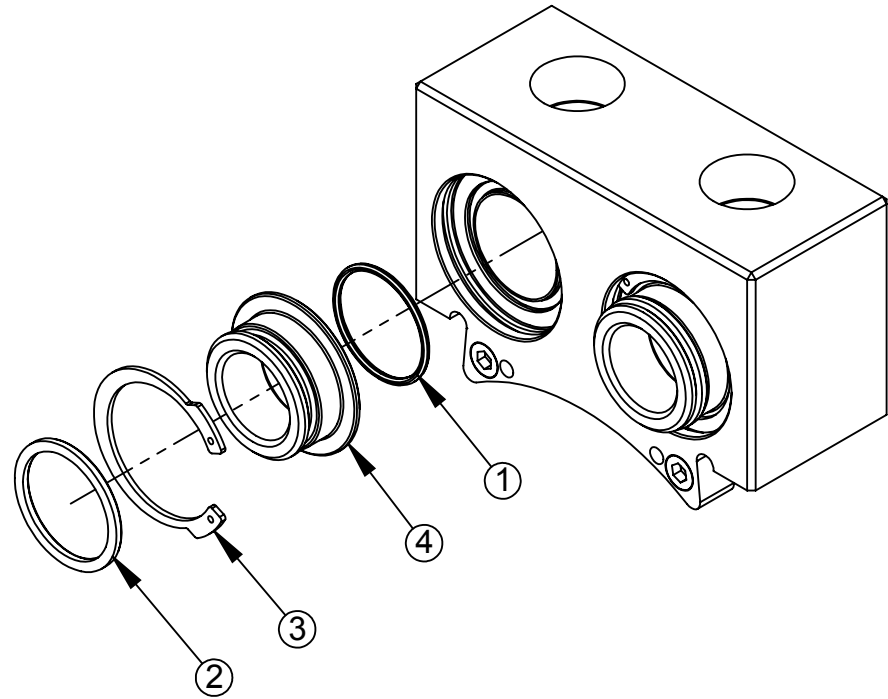
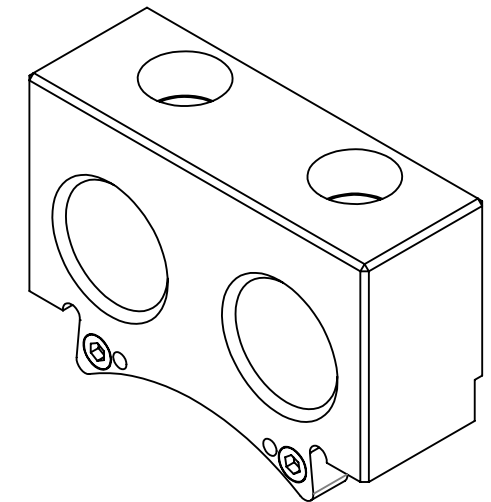

AD6-T  
NO SERVICEABLE PARTS

- NOTES:  
MATERIALS OF CONSTRUCTION:  
1. HOUSINGS- ALUMINUM  
2. NIPPLE PORT- STAINLESS STEEL  
3. SEALS- BUNA-N (NITRILE)

- OPERATION:  
4. PNEUMATIC OPERATION ONLY.  
5. FOR OPTIMUM PERFORMANCE INSPECT ANNULAR SEAL REGULARLY AND REPLACE AS NEEDED.

**AD6-M SERVICEABLE PARTS**

ITEM NO.	QTY.	PART NUMBER	DESCRIPTION
1	2	3410-0001015-01	O-Ring Master AS568-026
2	2	3410-0001392-01	O-Ring, AS568-218, Buna-N, D70
3	2	3690-8500001-11	Retaining Ring, Internal Inverted Truarc # 5008-187
4	2	3700-20-8095	1" Air Pass Through Nipple

ITEM NO.	QTY	PART NUMBER	DESCRIPTION
1	1	9121-AD6-M	(2) 3/4" NPT Pass Through Module - Master Side
2	1	9121-AD6-T	(2) 3/4" NPT Pass Through Module - Tool Side

NOTES: UNLESS OTHERWISE SPECIFIED.

DO NOT SCALE DRAWING. ALL DIMENSIONS ARE IN MILLIMETERS.



3rd ANGLE PROJECTION



1031 Goodworth Drive, Apex, NC 27539, USA  
Tel: +1.919.772.0115 Email: info@ati-ia.com  
Fax: +1.919.772.8259 www.ati-ia.com  
ISO 9001 Registered Company

PROPERTY OF ATI INDUSTRIAL AUTOMATION, INC. NOT TO BE REPRODUCED IN ANY MANNER EXCEPT ON ORDER OR WITH PRIOR WRITTEN AUTHORIZATION OF ATI.

DRAWN BY: K. Zachary 09/17/15		TITLE	
CHECKED BY: D. Norton 09/21/15		AD6 Air Pass Through Module Drawing	
PROJECT # 150909-1	SHEET 1 OF 1	SCALE 1:2	SIZE B
DRAWING NUMBER 9630-20-AD6		REVISION 01	