

Rev.	Description	Initiator	Date
02	ECO 19232; Added Note 6	LJH	6/28/22

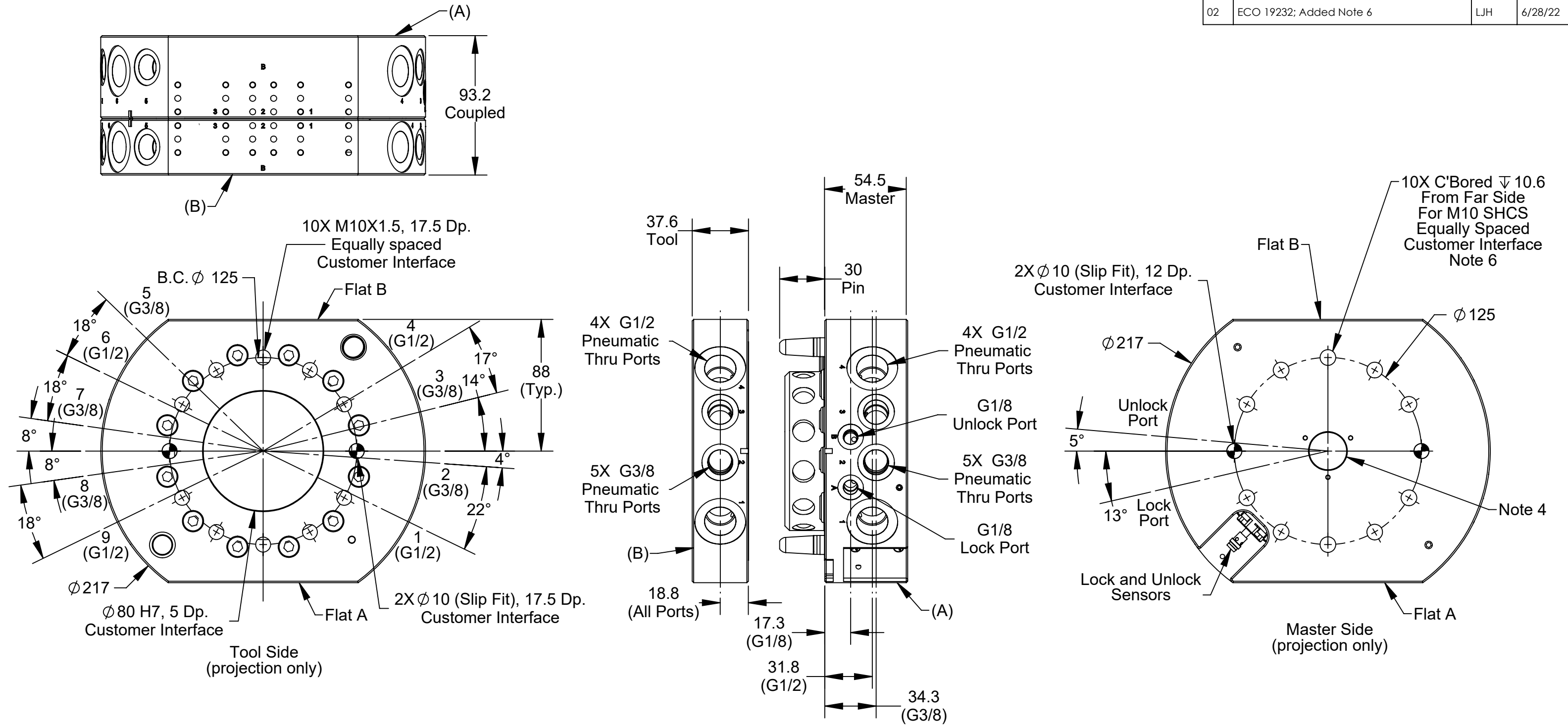

Part Numbers:
 (A) Master: 9120-160AM-000-000-SM-E
 (B) Tool: 9120-160FT-000-000-E

- Notes:
- Orientation marks are provided to assist in robot teaching.
 - SM on Master part number indicates PNP Lock/Unlock sensors. Lock/Unlock sensing is optional.
 - Ready to Lock sensor is available.
 - Plates available for several boss sizes.
 - QC max static moment rating $M_{xy}=2710Nm$, assuming all 10SHCS are used. QC Moment rating $M_{xy}=1355Nm$, if 6 fasteners are used on master.

NOTES: UNLESS OTHERWISE SPECIFIED.

DO NOT SCALE DRAWING. ALL DIMENSIONS ARE IN MILLIMETERS.

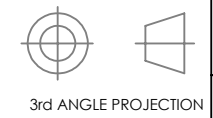

1031 Goodworth Drive, Apex, NC 27539, USA
 Tel: +1.919.772.0115 Email: info@ati-ia.com
 Fax: +1.919.772.8259 www.ati-ia.com
 ISO 9001 Registered Company

PROPERTY OF ATI INDUSTRIAL AUTOMATION, INC. NOT TO BE REPRODUCED IN ANY MANNER EXCEPT ON ORDER OR WITH PRIOR WRITTEN AUTHORIZATION OF ATI.

DRAWN BY: S. Jeffers, 6/20/2017		TITLE	
CHECKED BY: M. Gala, 6/21/2017		QC-160 Tool Changer, Euro	
PROJECT #	SHEET 1 OF 3	SCALE	SIZE
		2:5	B
DRAWING NUMBER		REVISION	
9630-20-160-E		02	

QC-160 Euro Master Assembly

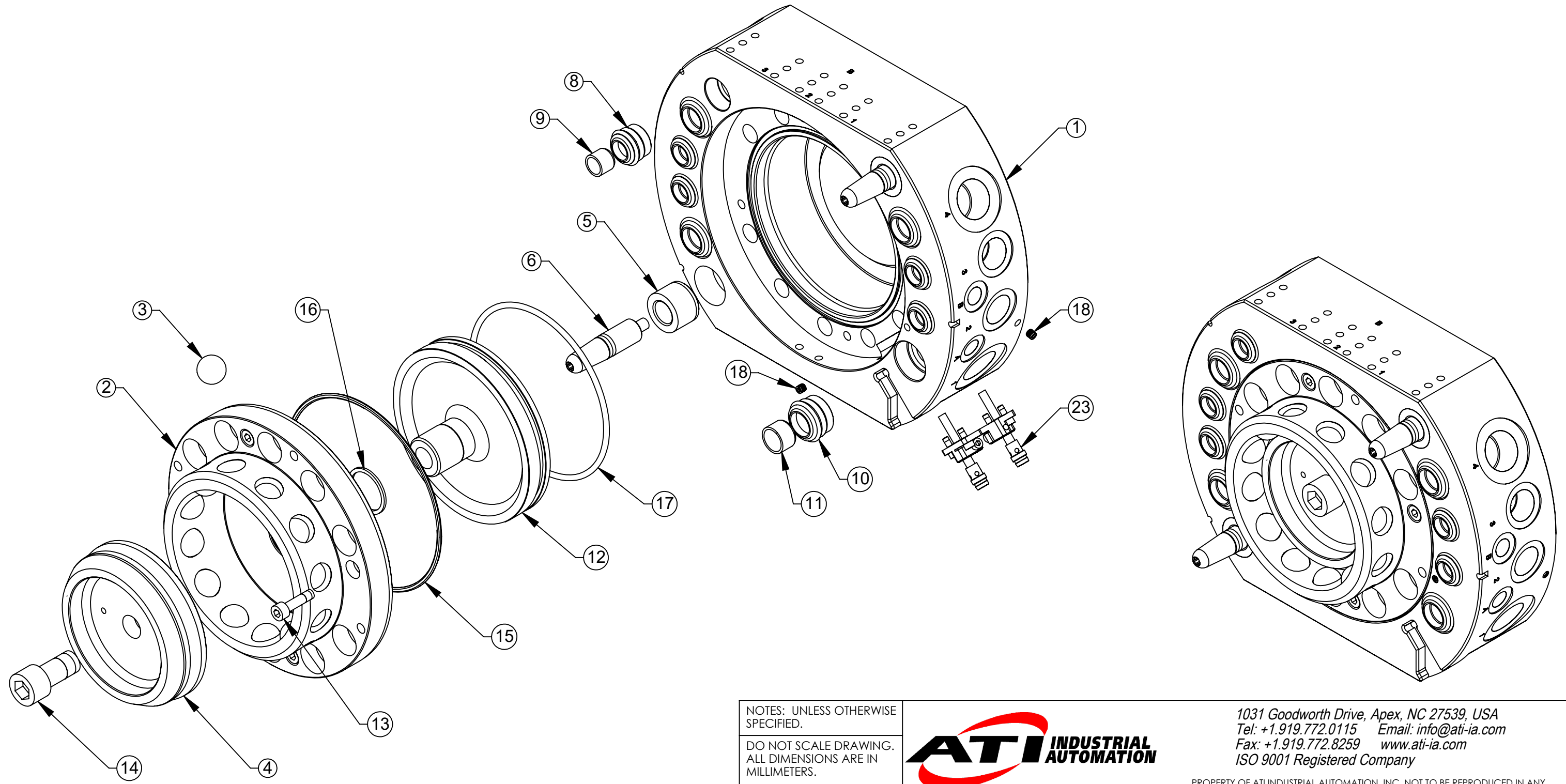

NOTES: UNLESS OTHERWISE SPECIFIED.

DO NOT SCALE DRAWING. ALL DIMENSIONS ARE IN MILLIMETERS.

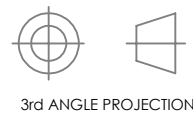

1031 Goodworth Drive, Apex, NC 27539, USA
 Tel: +1.919.772.0115 Email: info@ati-ia.com
 Fax: +1.919.772.8259 www.ati-ia.com
 ISO 9001 Registered Company

PROPERTY OF ATI INDUSTRIAL AUTOMATION, INC. NOT TO BE REPRODUCED IN ANY MANNER EXCEPT ON ORDER OR WITH PRIOR WRITTEN AUTHORIZATION OF ATI.

DRAWN BY: S. Jeffers, 6/20/2017		TITLE	
CHECKED BY: M. Gala, 6/21/2017		QC-160 Tool Changer, Euro	
PROJECT #	SHEET 2 OF 3	SCALE	REVISION
		1:2	02
		SIZE	DRAWING NUMBER
		B	9630-20-160-E

QC-160 Euro Tool Assembly

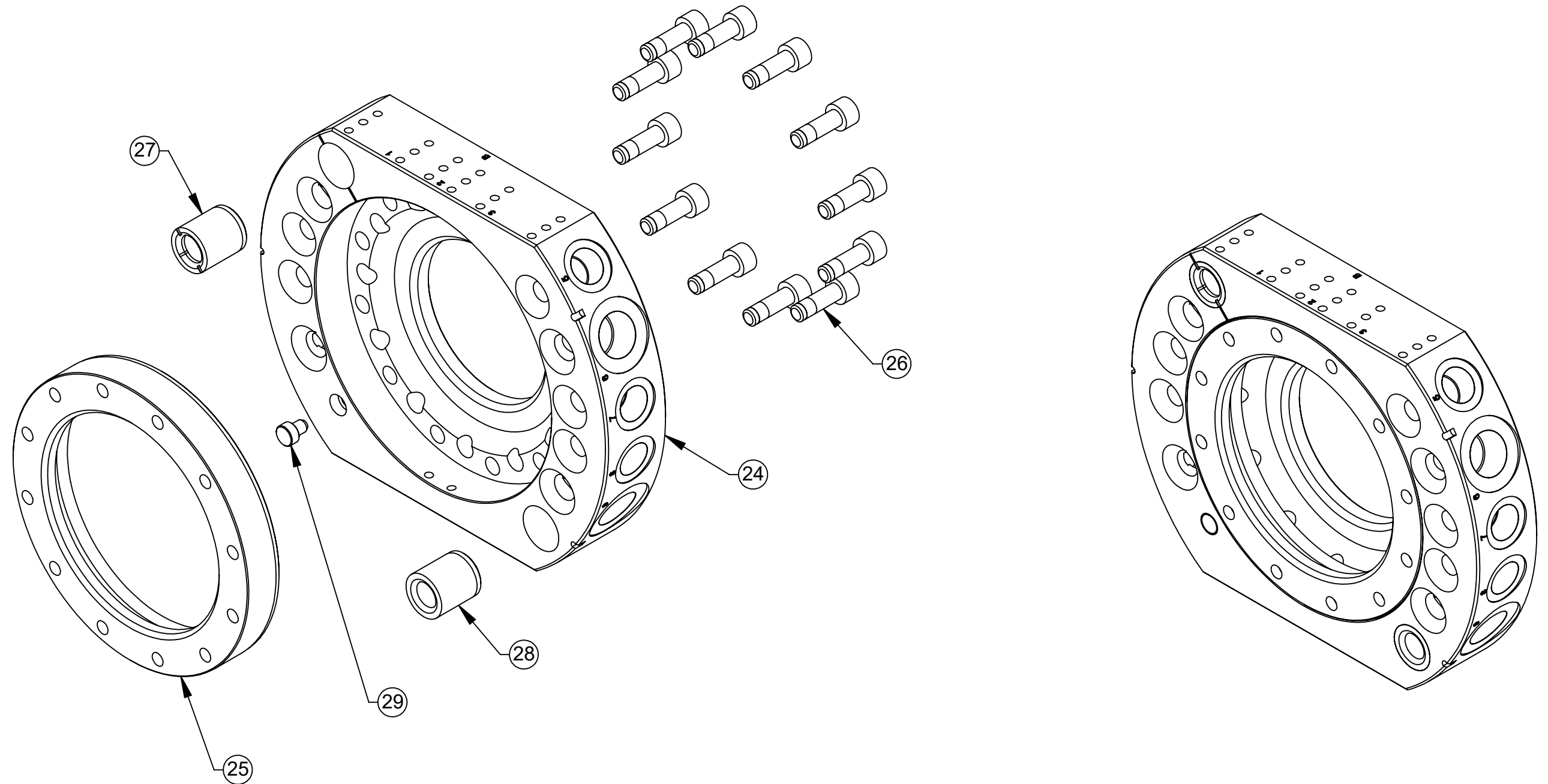

NOTES: UNLESS OTHERWISE SPECIFIED.

DO NOT SCALE DRAWING. ALL DIMENSIONS ARE IN MILLIMETERS.



3rd ANGLE PROJECTION



1031 Goodworth Drive, Apex, NC 27539, USA
 Tel: +1.919.772.0115 Email: info@ati-ia.com
 Fax: +1.919.772.8259 www.ati-ia.com
 ISO 9001 Registered Company

PROPERTY OF ATI INDUSTRIAL AUTOMATION, INC. NOT TO BE REPRODUCED IN ANY MANNER EXCEPT ON ORDER OR WITH PRIOR WRITTEN AUTHORIZATION OF ATI.

DRAWN BY: S. Jeffers, 6/20/2017		TITLE		
CHECKED BY: M. Gala, 6/21/2017		QC-160 Tool Changer, Euro		
PROJECT #	SHEET 3 OF 3	SCALE	SIZE	DRAWING NUMBER
		1:2	B	9630-20-160-E
				REVISION
				02