

Rev.	Description	Initiator	Date
02	Added 2X 8mm SF dowels to Master customer interface.	KRZ	06/23/14

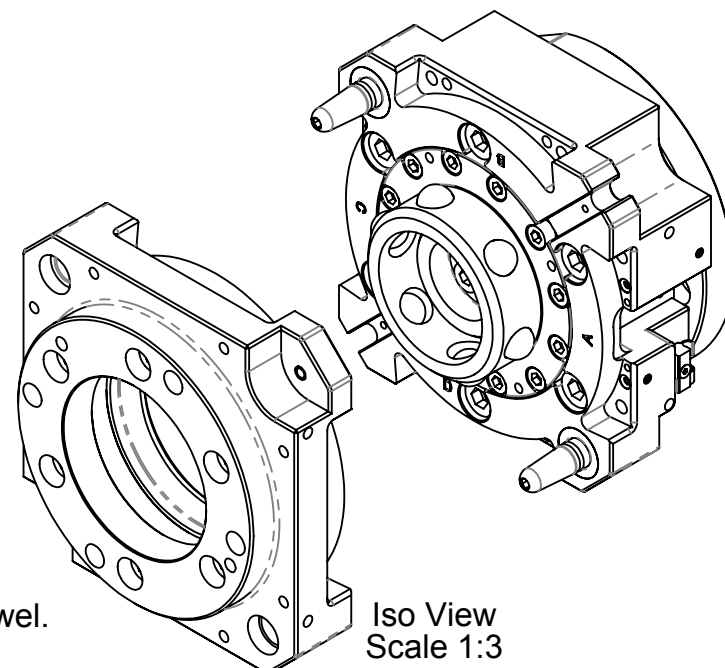

ITEM NO.	QTY.	PART NUMBER	DESCRIPTION
1	1	9121-113AMX-0-0-0-0	QC-113 Master Base Assembly (Sleeveless), No Options
2	1	9121-113BT-0-0-0-0	QC-113 Tool with 80mm Recess

NOTES: UNLESS OTHERWISE SPECIFIED.
DO NOT SCALE DRAWING. ALL DIMENSIONS ARE IN MILLIMETERS.

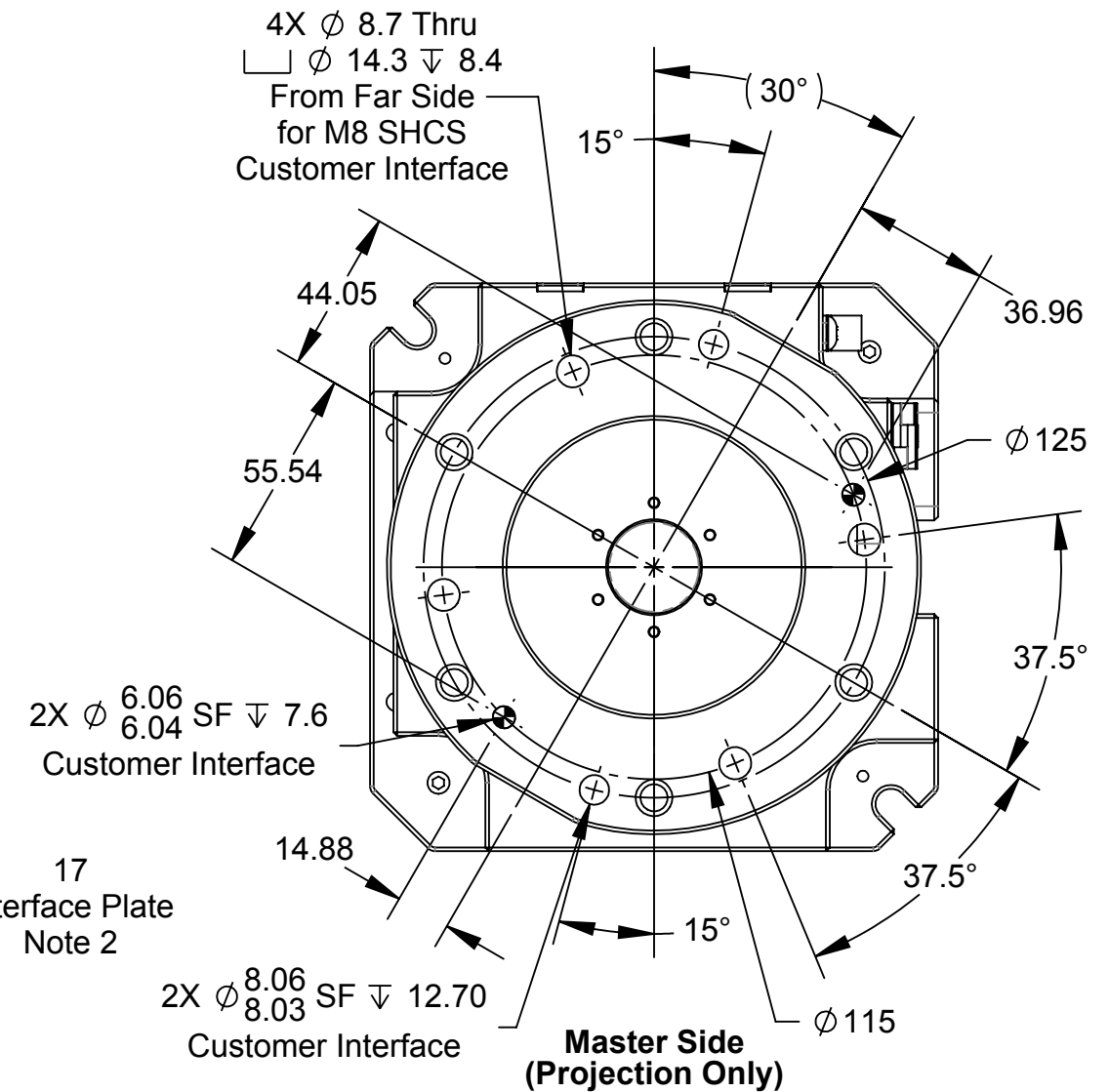
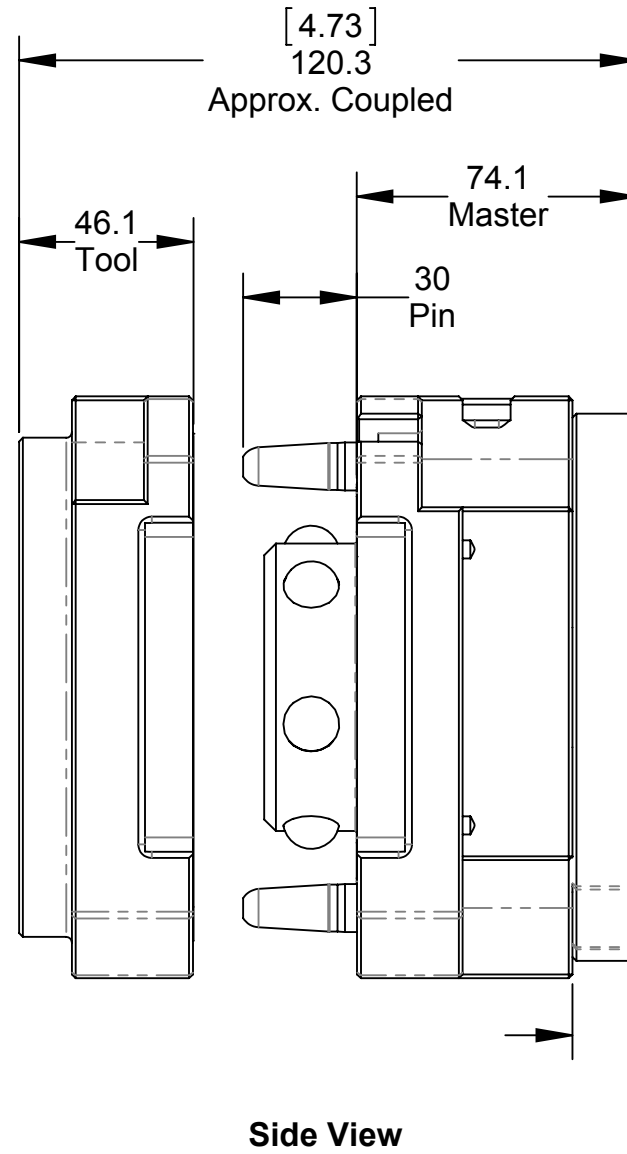
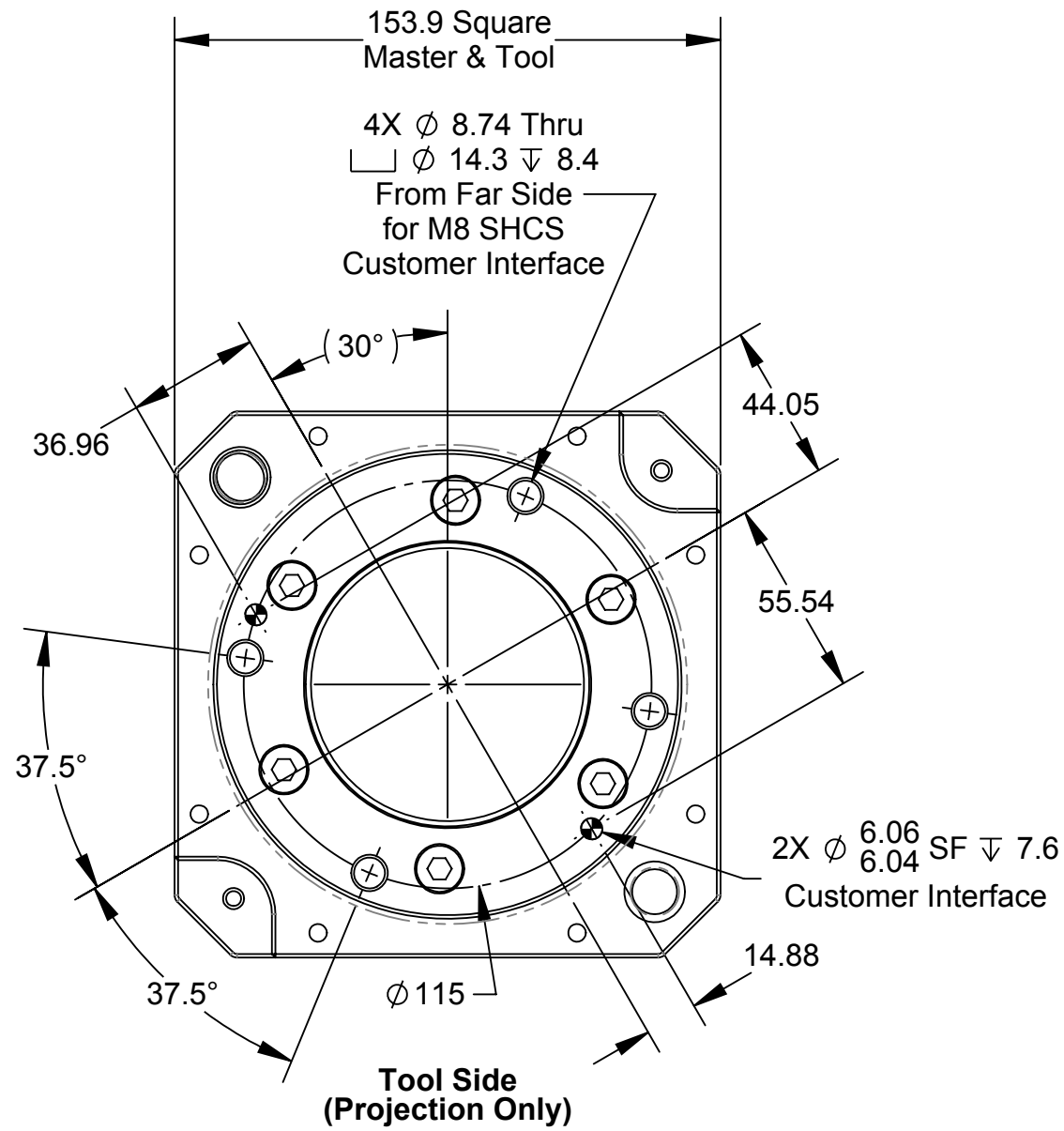

1031 Goodworth Drive, Apex, NC 27539, USA
Tel: +1.919.772.0115 Email: info@ati-ia.com
Fax: +1.919.772.8259 www.ati-ia.com
ISO 9001 Registered Company

PROPERTY OF ATI INDUSTRIAL AUTOMATION, INC. NOT TO BE REPRODUCED IN ANY MANNER EXCEPT ON ORDER OR WITH PRIOR WRITTEN AUTHORIZATION OF ATI.

Notes:
1. Design is subject to change.
2. Without interface plate Master features ISO 125mm mounting pattern - (6) M10 SHCS and (2) 10mm dowel. Optional Master side mounting bosses available.



DRAWN BY: K. Zachary 05/08/14		TITLE	
CHECKED BY: D. Norton 05/08/14		QC-113 Base Tool Changer	
PROJECT # 131028-1	SHEET 1 OF 3	SCALE 1:2	SIZE B
		DRAWING NUMBER 9630-20-113	REVISION 02

QC-113 Master Assembly

Rev.	Description	Initiator	Date
-	See Sheet1	-	-

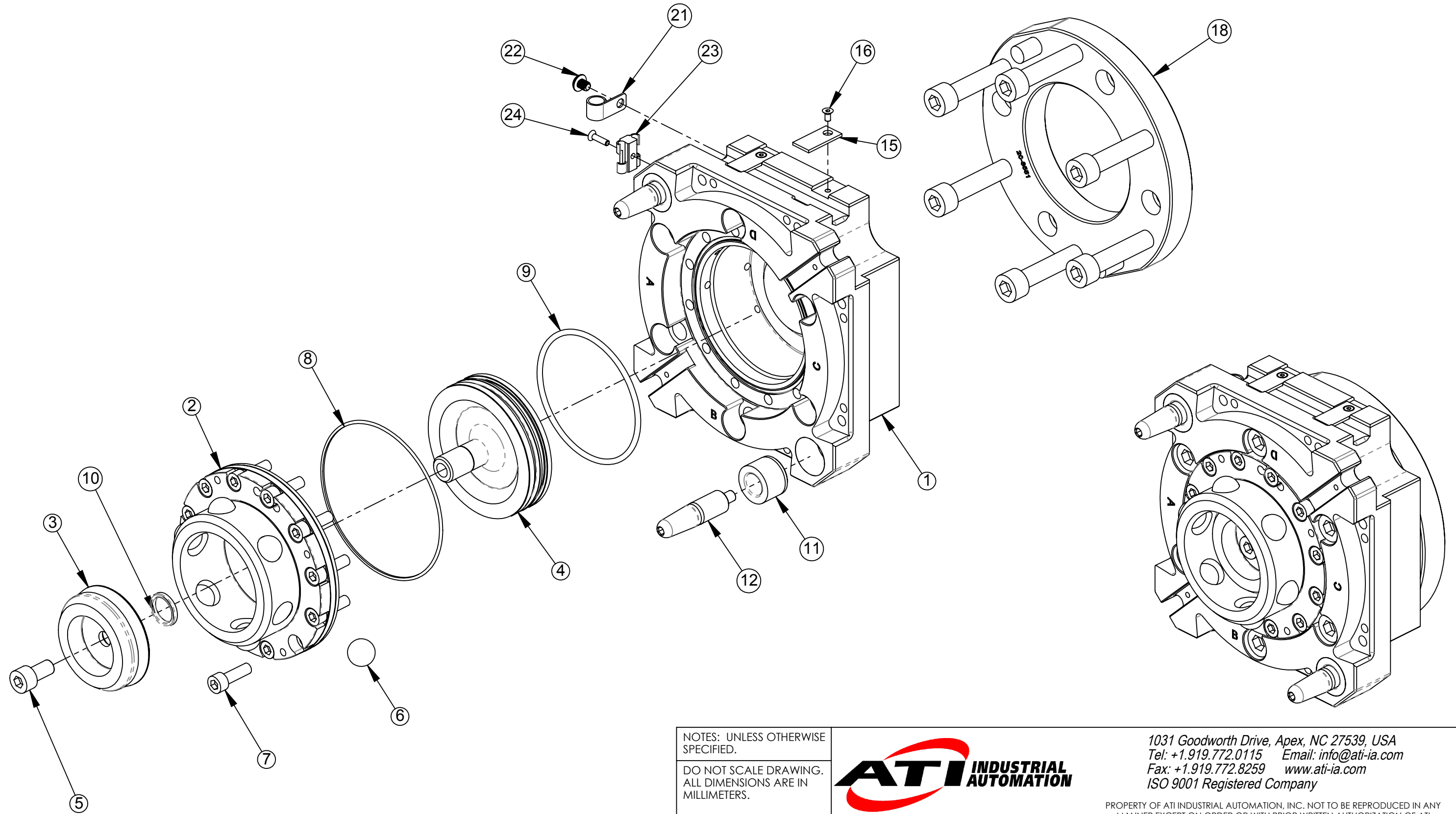

NOTES: UNLESS OTHERWISE SPECIFIED.

DO NOT SCALE DRAWING. ALL DIMENSIONS ARE IN MILLIMETERS.



1031 Goodworth Drive, Apex, NC 27539, USA
 Tel: +1.919.772.0115 Email: info@ati-ia.com
 Fax: +1.919.772.8259 www.ati-ia.com
 ISO 9001 Registered Company

PROPERTY OF ATI INDUSTRIAL AUTOMATION, INC. NOT TO BE REPRODUCED IN ANY MANNER EXCEPT ON ORDER OR WITH PRIOR WRITTEN AUTHORIZATION OF ATI.

DRAWN BY: K. Zachary 05/08/14		TITLE	
CHECKED BY: D. Norton 05/08/14		QC-113 Base Tool Changer	
PROJECT # 131028-1	SHEET 2 OF 3	SCALE 1:2	SIZE B
DRAWING NUMBER 9630-20-113		REVISION 02	

QC-113 Tool Assembly

Rev.	Description	Initiator	Date
-	See Sheet1	-	-

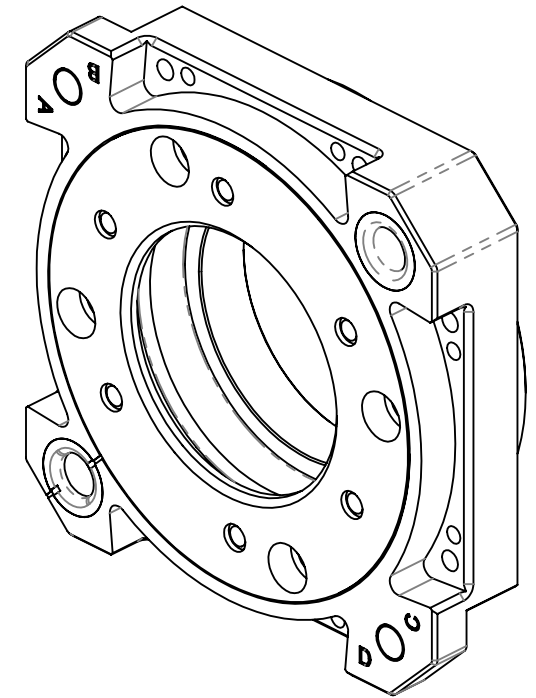
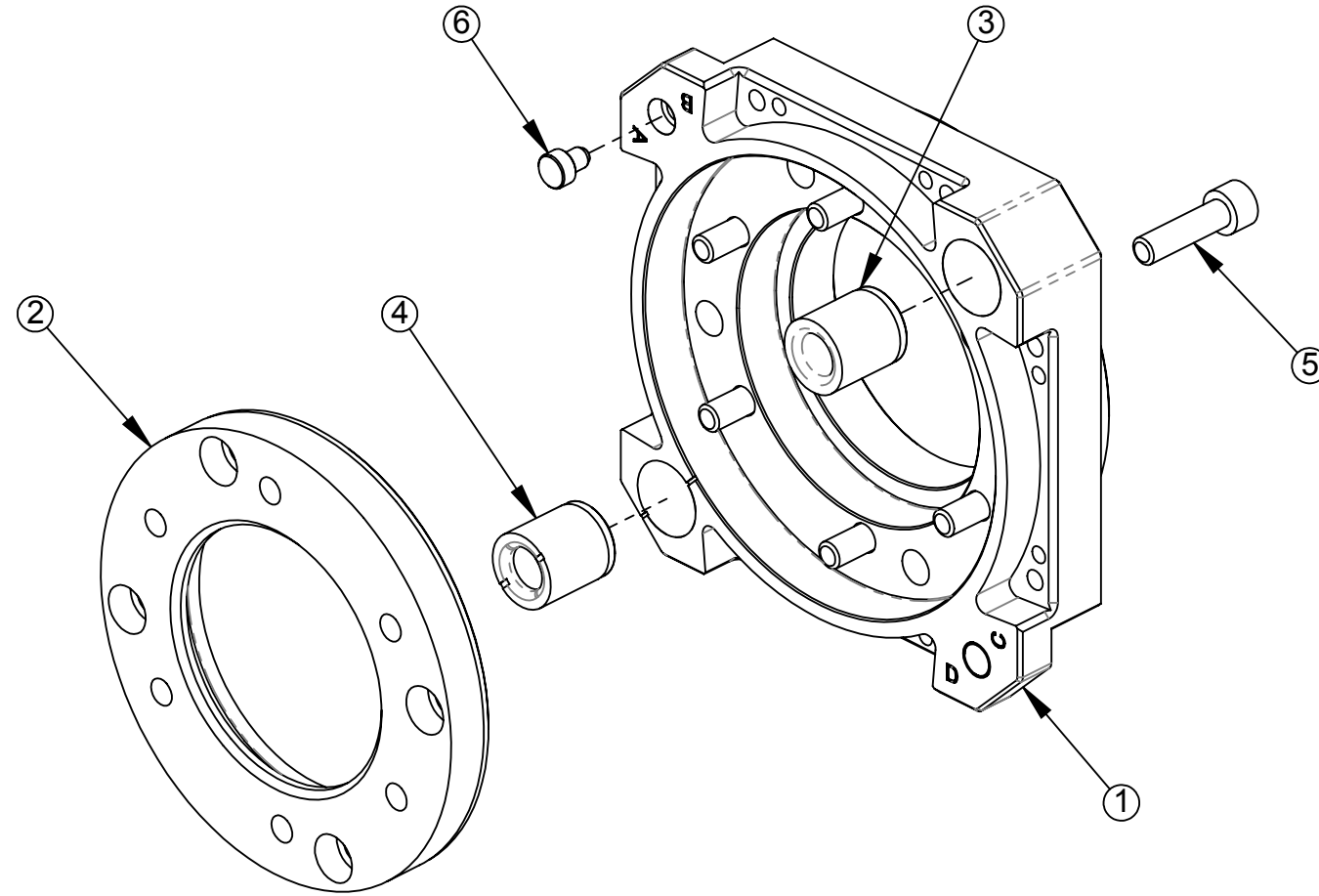

NOTES: UNLESS OTHERWISE SPECIFIED.

DO NOT SCALE DRAWING. ALL DIMENSIONS ARE IN MILLIMETERS.



3rd ANGLE PROJECTION



1031 Goodworth Drive, Apex, NC 27539, USA
 Tel: +1.919.772.0115 Email: info@ati-ia.com
 Fax: +1.919.772.8259 www.ati-ia.com
 ISO 9001 Registered Company

PROPERTY OF ATI INDUSTRIAL AUTOMATION, INC. NOT TO BE REPRODUCED IN ANY MANNER EXCEPT ON ORDER OR WITH PRIOR WRITTEN AUTHORIZATION OF ATI.

DRAWN BY: K. Zachary 05/08/14		TITLE	
CHECKED BY: D. Norton 05/08/14		QC-113 Base Tool Changer	
PROJECT #	131028-1	SHEET	OF 3
SCALE	1:2	SIZE	B
DRAWING NUMBER	9630-20-113		REVISION
			02