

Rev.	Description	Initiator	Date
04	ECO 20228: Sheet 1: Front View: Updated 30.2 Pin to 30 Pin. Sheet 3: 9120-110FT-000-000-R: Updated views for visual change from 3700-20-1386 to 3700-20-11660.	TBC	9/27/2021

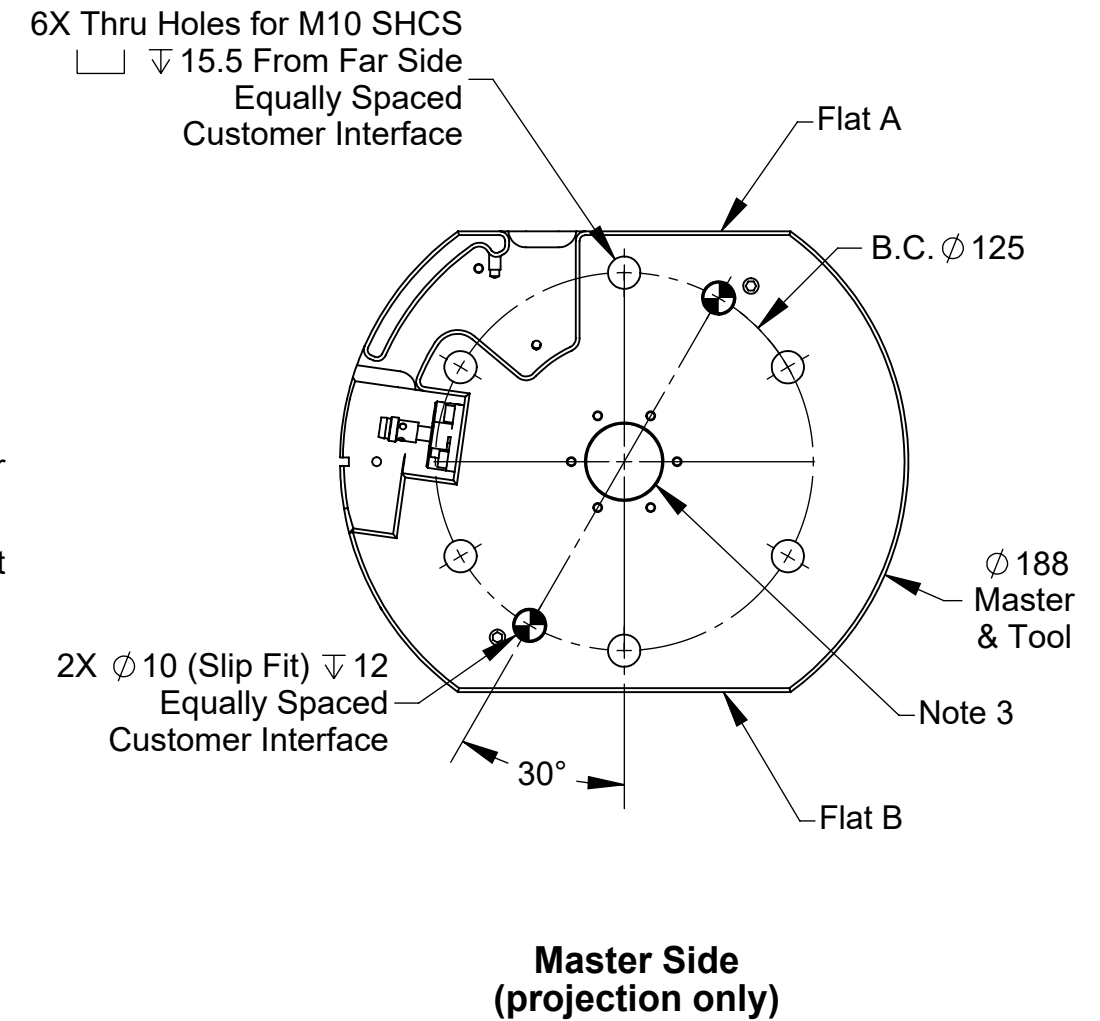
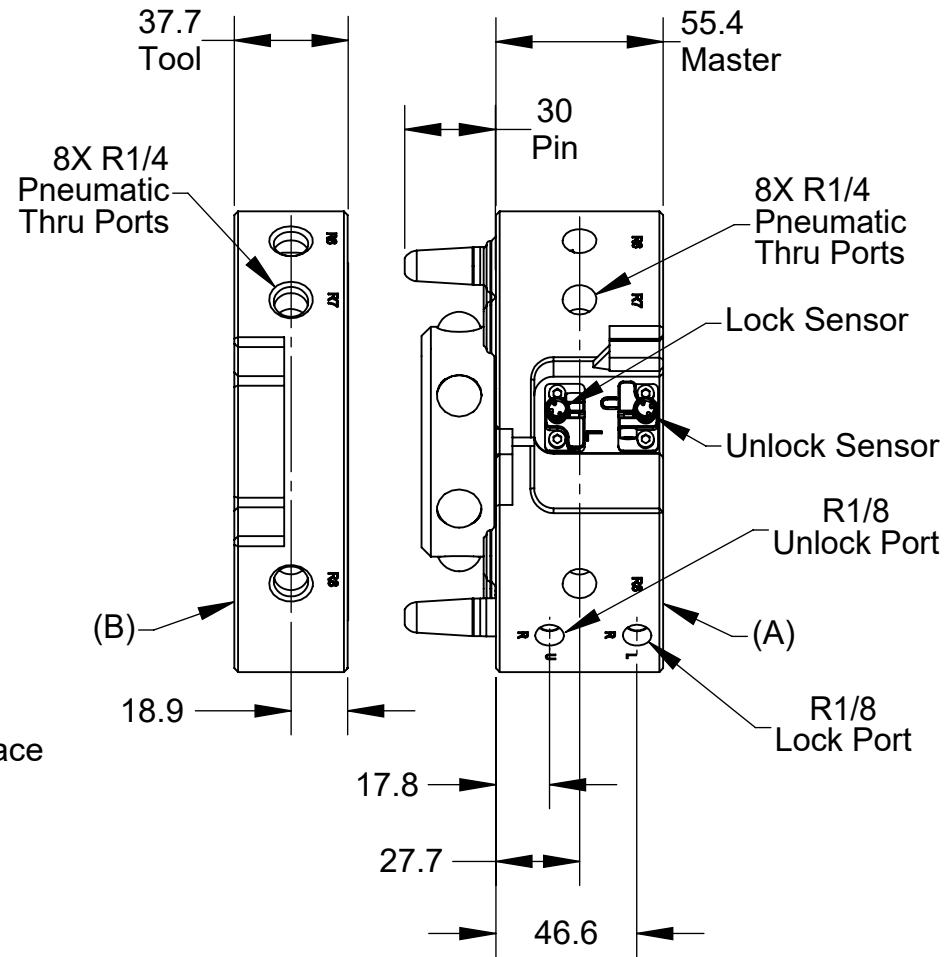
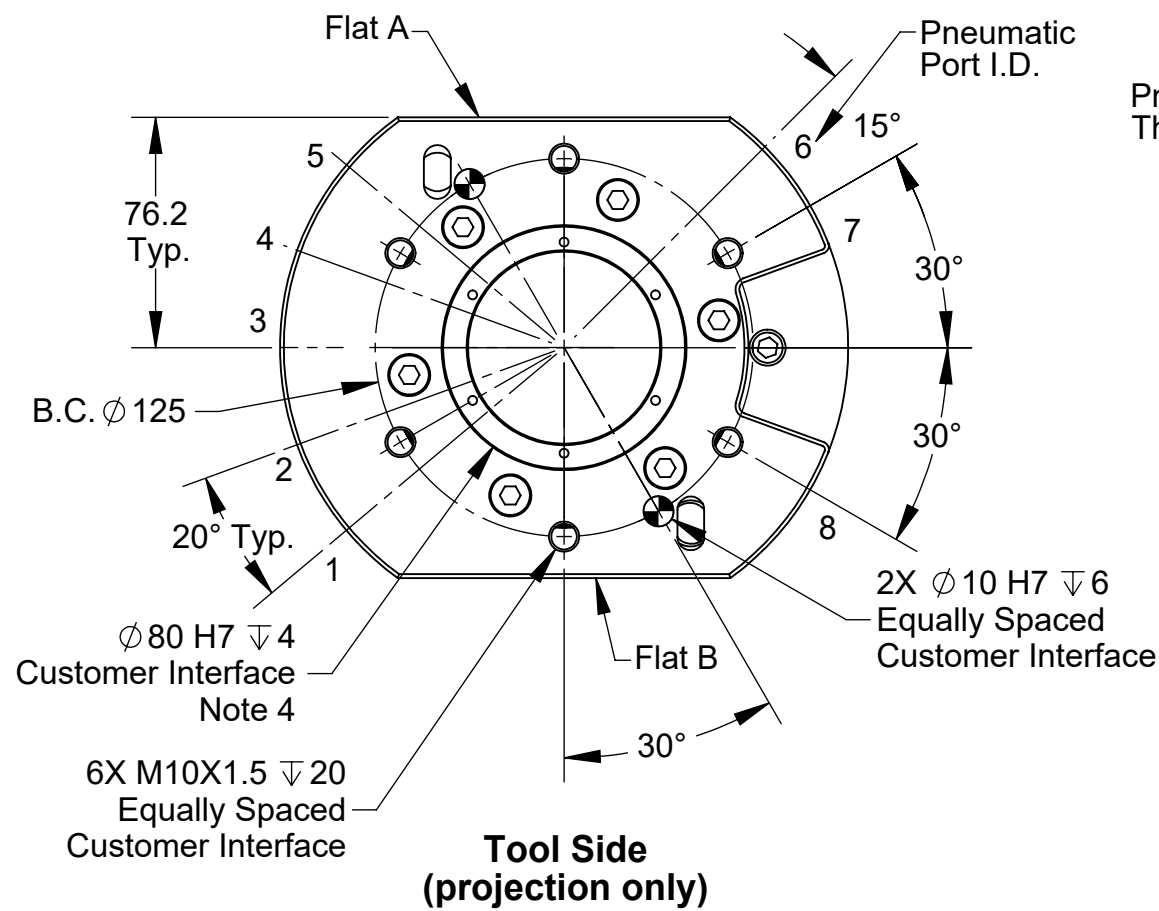
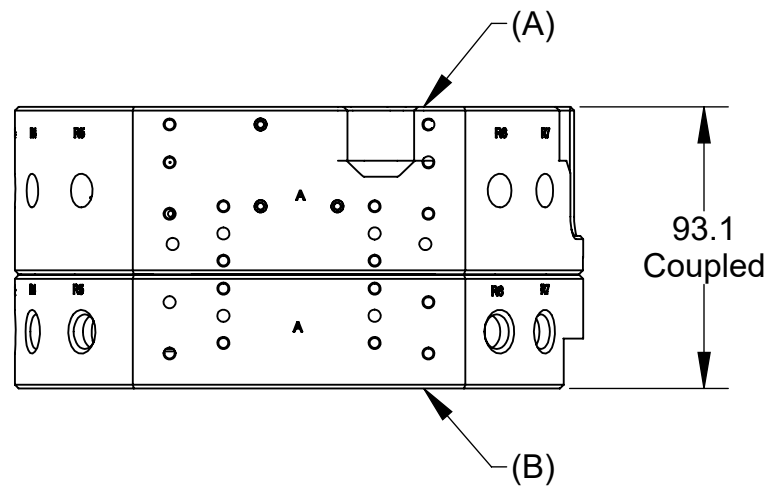

Part Numbers Shown:
 (A) Master: 9120-110AM-000-000-Sx-R
 (B) Tool: 9120-110FT-000-000-R

- Notes:
- The -Sx in the Master part number indicates the Lock/Unlock sensor option. Multiple sensor options are available.
 - Ready to Lock sensing is available.
 - Center boss inserts available for several sizes.
 - Center recess inserts available for several sizes.

NOTES: UNLESS OTHERWISE SPECIFIED.

DO NOT SCALE DRAWING. ALL DIMENSIONS ARE IN MILLIMETERS.

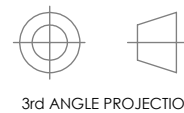

1031 Goodworth Drive, Apex, NC 27539, USA
 Tel: +1.919.772.0115 www.ati-ia.com
 Fax: +1.919.772.8259 ISO 9001 Registered Company

PROPERTY OF ATI INDUSTRIAL AUTOMATION, INC. NOT TO BE REPRODUCED IN ANY MANNER EXCEPT ON ORDER OR WITH PRIOR WRITTEN AUTHORIZATION OF ATI.

DRAWN BY: D. Swanson 6/9/09		TITLE	
CHECKED BY: D. Wagner 6/10/09		QC-110 Tool Changer with 1/4 BSPT Ports	
PROJECT #	SHEET 1 OF 3	SCALE	REVISION
		1:2.5	04
		SIZE	DRAWING NUMBER
		B	9630-20-110-R

QC-110-R Master Assembly

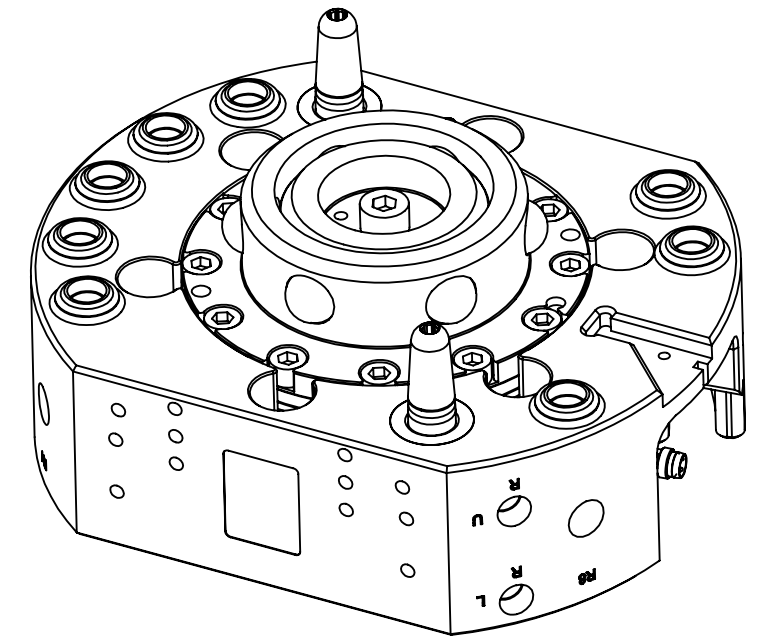
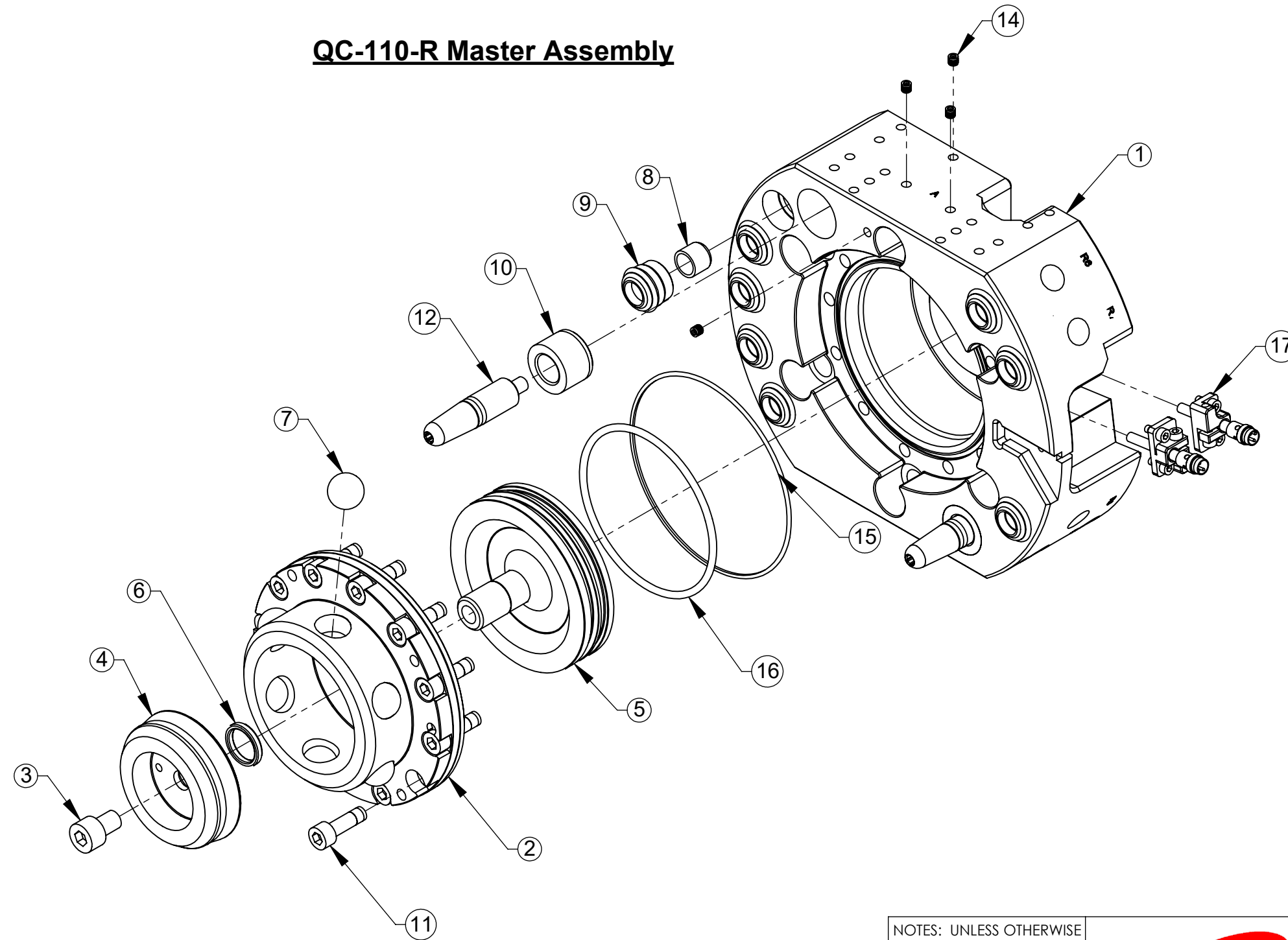

NOTES: UNLESS OTHERWISE SPECIFIED.

DO NOT SCALE DRAWING. ALL DIMENSIONS ARE IN MILLIMETERS.



3rd ANGLE PROJECTION



1031 Goodworth Drive, Apex, NC 27539, USA
 Tel: +1.919.772.0115 www.ati-ia.com
 Fax: +1.919.772.8259 ISO 9001 Registered Company

PROPERTY OF ATI INDUSTRIAL AUTOMATION, INC. NOT TO BE REPRODUCED IN ANY MANNER EXCEPT ON ORDER OR WITH PRIOR WRITTEN AUTHORIZATION OF ATI.

DRAWN BY: D. Swanson 6/9/09		TITLE		
CHECKED BY: D. Wagner 6/10/09		QC-110 Tool Changer with 1/4 BSPT Ports		
PROJECT #	SHEET 2 OF 3	SCALE	SIZE	DRAWING NUMBER
		1:2	B	9630-20-110-R
				REVISION
				04

QC-110-R Tool Assembly

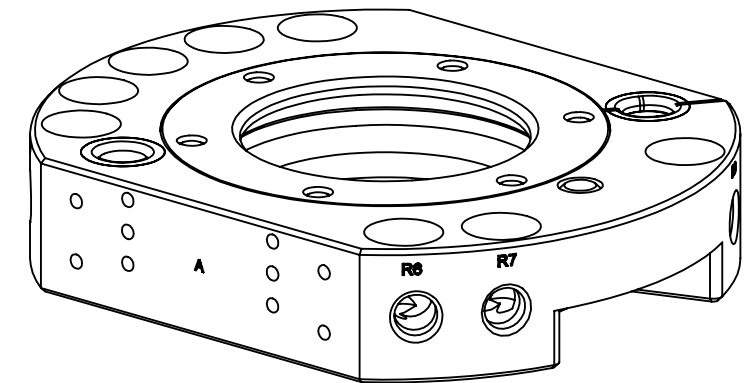
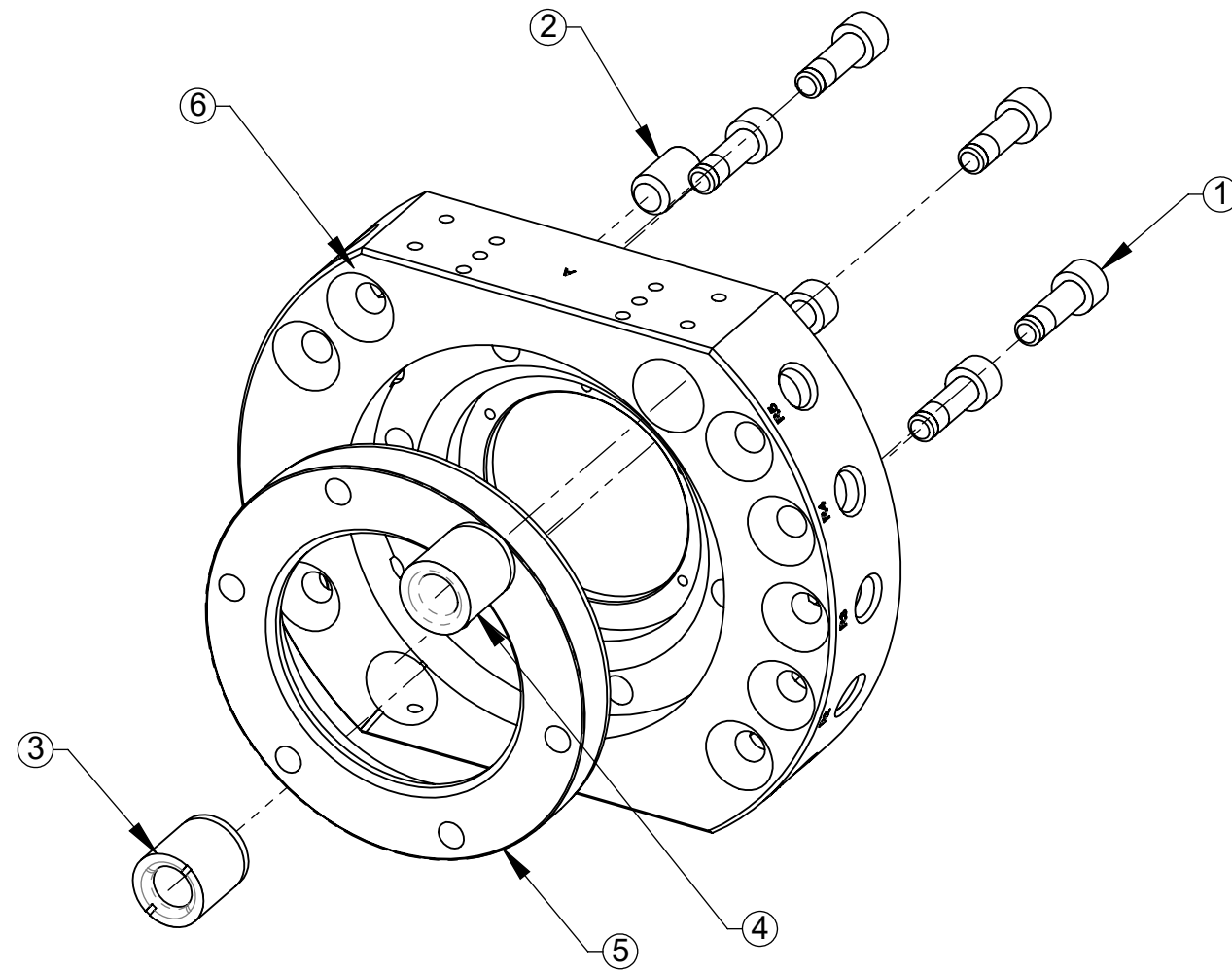

NOTES: UNLESS OTHERWISE SPECIFIED.

DO NOT SCALE DRAWING. ALL DIMENSIONS ARE IN MILLIMETERS.



3rd ANGLE PROJECTION



1031 Goodworth Drive, Apex, NC 27539, USA
 Tel: +1.919.772.0115 www.ati-ia.com
 Fax: +1.919.772.8259 ISO 9001 Registered Company

PROPERTY OF ATI INDUSTRIAL AUTOMATION, INC. NOT TO BE REPRODUCED IN ANY MANNER EXCEPT ON ORDER OR WITH PRIOR WRITTEN AUTHORIZATION OF ATI.

DRAWN BY: D. Swanson 6/9/09		TITLE		
CHECKED BY: D. Wagner 6/10/09		QC-110 Tool Changer with 1/4 BSPT Ports		
PROJECT #	SHEET 3 OF 3	SCALE	SIZE	DRAWING NUMBER
		1:2	B	9630-20-110-R
				REVISION
				04