

PART NUMBERS:  
 (A): 9120-071M-000-000  
 (B): 9120-071T-000-000

REV.	DESCRIPTION	INITIATOR	DATE
01	INITIAL RELEASE	NWB	7/24/2020
02	ECO 19269; RELEASE DRAWING	DS	8/18/2020

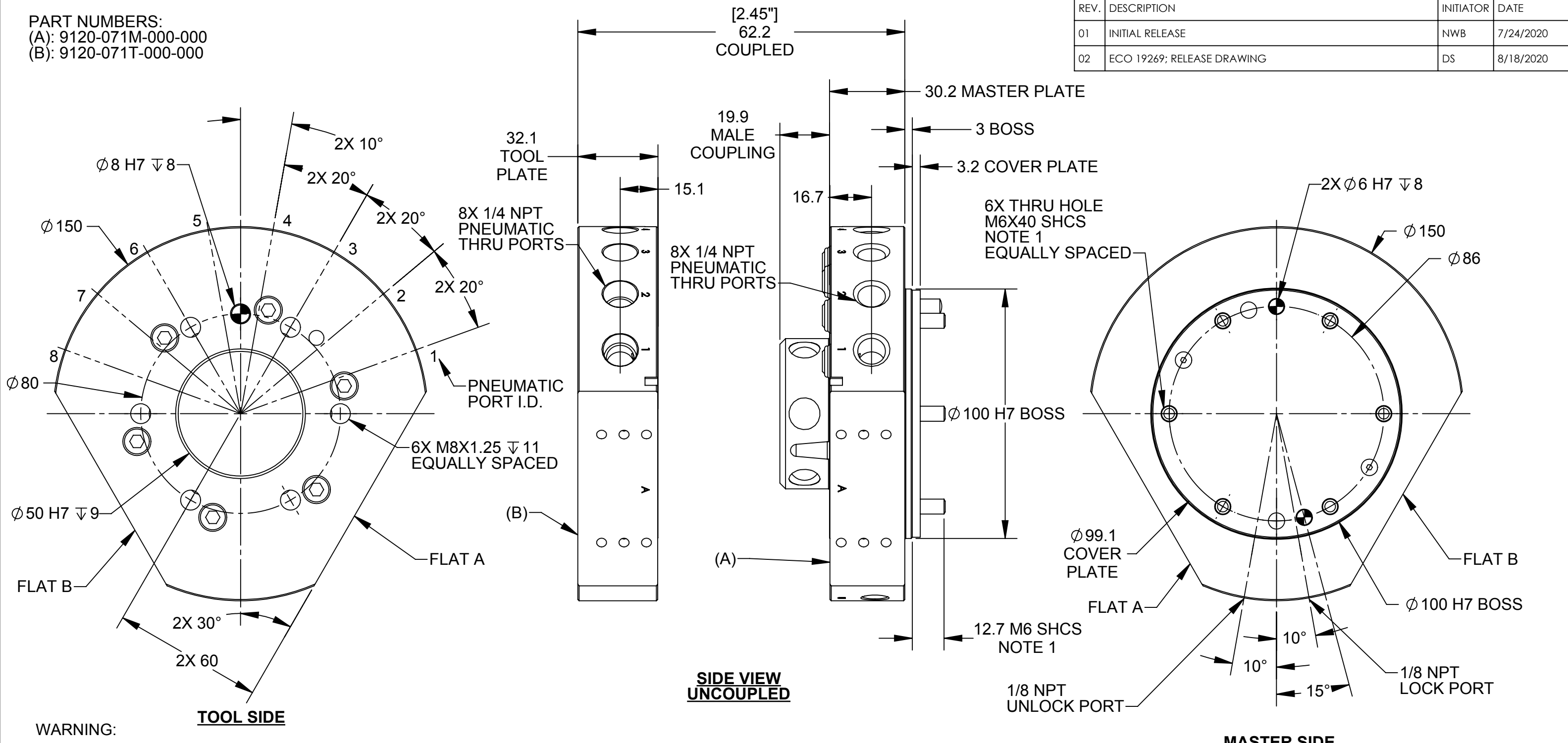

**WARNING:**  
 DO NOT APPLY LOCK/UNLOCK AIR PRESSURE WITHOUT MASTER COVER PLATE PROPERLY ATTACHED. IF COVER PLATE IS NOT USED, MASTER SHOULD BE PROPERLY ATTACHED TO INTERFACE. FAILURE TO DO SO COULD RESULT IN DAMAGE TO COVER PLATE AND O-RING.

- NOTES:**
1. MASTER SIDE MOUNTING HARDWARE PROVIDED.
  2. COVER PLATE IS NOT NECESSARY IF ROBOT INTERFACE PLATE PROVIDES SEALING. THE RECOMMENDED INTERFACE PLATE BORE DEPTH WITHOUT A COVER PLATE IS 2.5MM, WITH A COVER PLATE IS 5.6MM.
  3. ORIENTATION MARKS ARE PROVIDED TO ASSIST IN ROBOT TEACHING.
  4. LOCK/UNLOCK SENSING OPTIONS ARE AVAILABLE
  5. INTERFACE PLATES ARE AVAILABLE TO ADAPT THE TOOL CHANGER TO SPECIFIC MOUNTING PATTERNS
  6. CONTACT ATI FOR FULL PART NUMBERS AND LIST OF OPTIONS

NOTES: UNLESS OTHERWISE SPECIFIED.

DO NOT SCALE DRAWING. ALL DIMENSIONS ARE IN MILLIMETERS.

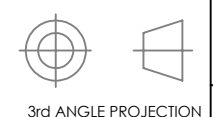

1031 Goodworth Drive, Apex, NC 27539, USA  
 Tel: +1.919.772.0115 www.ati-ia.com  
 Fax: +1.919.772.8259 ISO 9001 Registered Company

PROPERTY OF ATI INDUSTRIAL AUTOMATION, INC. NOT TO BE REPRODUCED IN ANY MANNER EXCEPT ON ORDER OR WITH PRIOR WRITTEN AUTHORIZATION OF ATI.

DRAWN BY: N. BADER 7/24/2020		TITLE	
CHECKED BY: D. WAGNER 7/29/2020		QC-71 TOOL CHANGER DRAWING	
PROJECT # -	SHEET 1 OF 3	SCALE	REVISION
		2:3	02
		SIZE	DRAWING NUMBER
		B	9630-20-071

# QC-71 MASTER

9120-071M-000-000

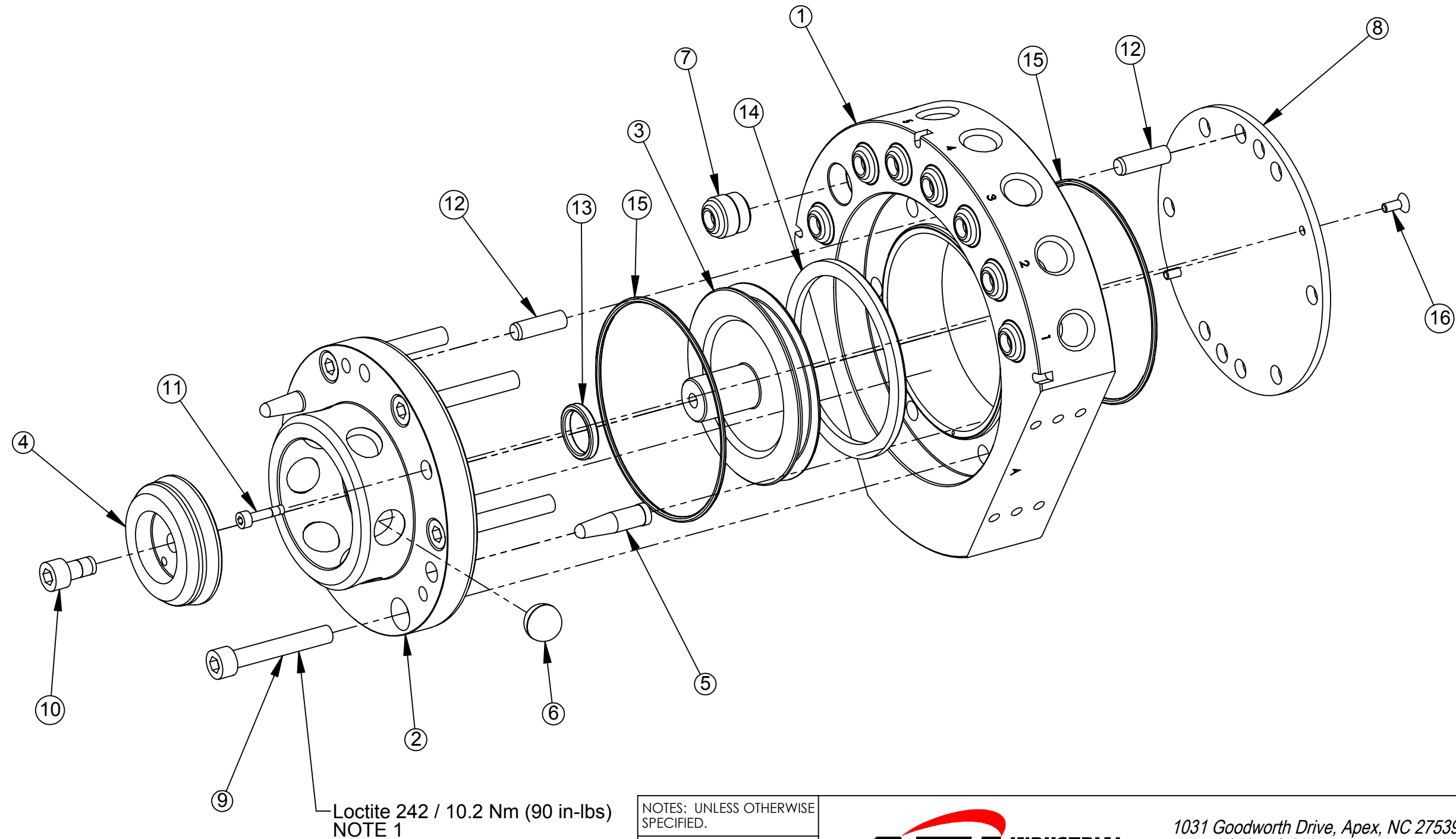

NOTES  
1. ASSEMBLE WITH FASTENERS AS LABELED

Loctite 242 / 10.2 Nm (90 in-lbs)  
NOTE 1

NOTES: UNLESS OTHERWISE SPECIFIED.

DO NOT SCALE DRAWING. ALL DIMENSIONS ARE IN MILLIMETERS.

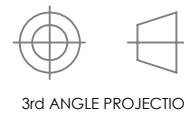

1031 Goodworth Drive, Apex, NC 27539, USA  
Tel: +1.919.772.0115 www.ati-ia.com  
Fax: +1.919.772.8259 ISO 9001 Registered Company

PROPERTY OF ATI INDUSTRIAL AUTOMATION, INC. NOT TO BE REPRODUCED IN ANY MANNER EXCEPT ON ORDER OR WITH PRIOR WRITTEN AUTHORIZATION OF ATI.

DRAWN BY: N. BADER 7/24/2020		TITLE	
CHECKED BY: D. WAGNER 7/29/2020		QC-71 TOOL CHANGER DRAWING	
PROJECT # -	SHEET 2 OF 3	SCALE	REVISION
		2:3	02
		SIZE	DRAWING NUMBER
		B	9630-20-071

# QC-71 TOOL

9120-071T-000-000

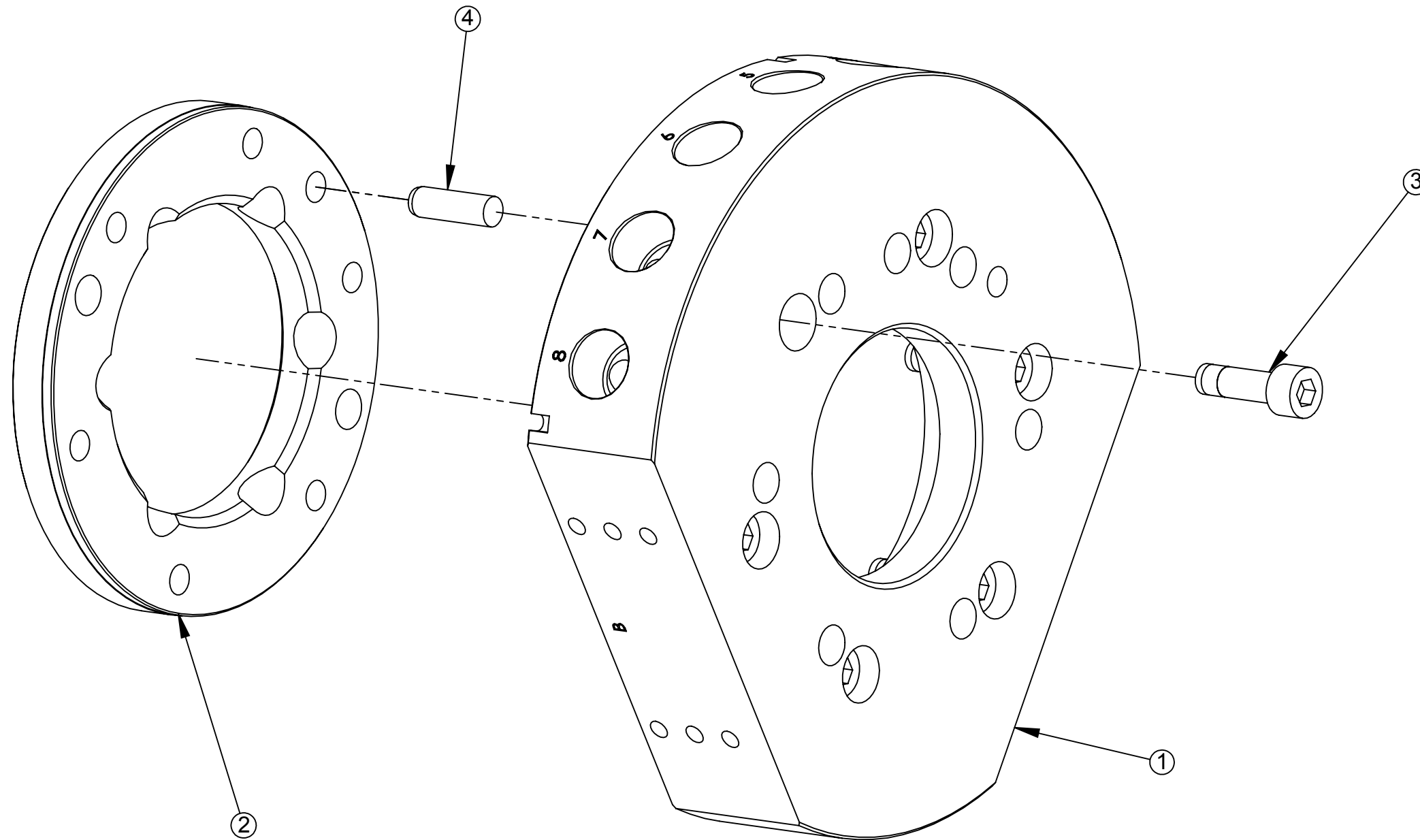

NOTES: UNLESS OTHERWISE SPECIFIED.

DO NOT SCALE DRAWING. ALL DIMENSIONS ARE IN MILLIMETERS.



3rd ANGLE PROJECTION



1031 Goodworth Drive, Apex, NC 27539, USA  
 Tel: +1.919.772.0115 [www.ati-ia.com](http://www.ati-ia.com)  
 Fax: +1.919.772.8259 ISO 9001 Registered Company

PROPERTY OF ATI INDUSTRIAL AUTOMATION, INC. NOT TO BE REPRODUCED IN ANY MANNER EXCEPT ON ORDER OR WITH PRIOR WRITTEN AUTHORIZATION OF ATI.

DRAWN BY: N. BADER 7/24/2020

CHECKED BY: D. WAGNER 7/29/2020

TITLE

QC-71 TOOL CHANGER DRAWING

PROJECT # -

SHEET 3 OF 3

SCALE  
1:1

SIZE  
B

DRAWING NUMBER  
9630-20-071

REVISION  
02