

Rev.	Description	Initiator	Date
02	ECO 14564; Master Side 6 H7 ∇ 10 Customer Interface was ∇ 22	SZJ	6/21/2016

Part Numbers:
 (A) Master: 9120-041M-000-000-E
 (B) Tool: 9120-041T-000-000-E

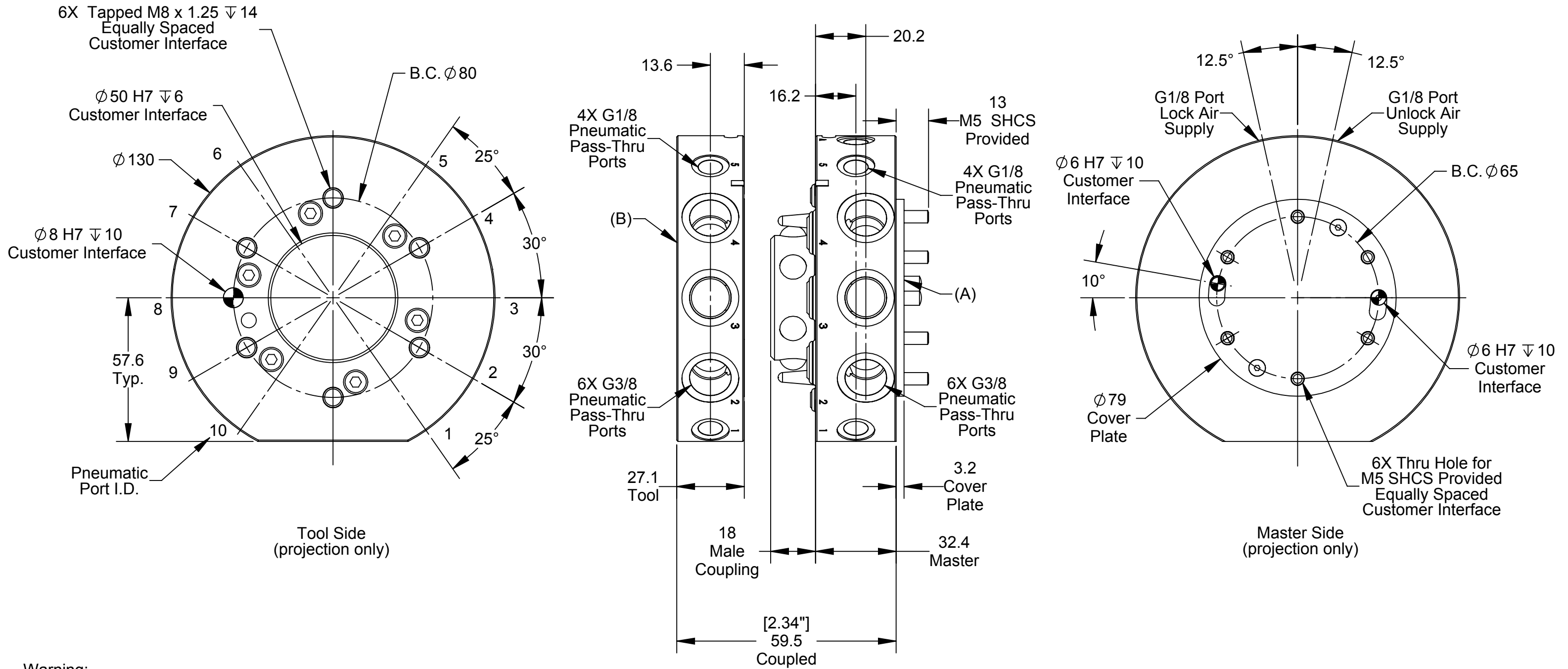

Warning:
 Do not apply lock/unlock air pressure without master cover plate properly attached. If cover plate is not used, master should be properly attached to interface. Failure to do so could result in damage to cover plate and o-ring.

- Notes:**
- Master side mounting hardware provided.
 - Cover plate is not necessary if robot interface plate provides sealing. The recommended interface plate bore depth with a cover plate is 2.5mm.
 - Orientation marks are provided to assist in robot teaching.

NOTES: UNLESS OTHERWISE SPECIFIED.

DO NOT SCALE DRAWING. ALL DIMENSIONS ARE IN MILLIMETERS.

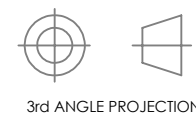

1031 Goodworth Drive, Apex, NC 27539, USA
 Tel: +1.919.772.0115 Email: info@ati-ia.com
 Fax: +1.919.772.8259 www.ati-ia.com
 ISO 9001 Registered Company

PROPERTY OF ATI INDUSTRIAL AUTOMATION, INC. NOT TO BE REPRODUCED IN ANY MANNER EXCEPT ON ORDER OR WITH PRIOR WRITTEN AUTHORIZATION OF ATI.

DRAWN BY: D. Swanson 11/6/15		TITLE	
CHECKED BY: D. Wagner 11/10/15		QC-41 Euro	
PROJECT # -	SHEET 1 OF 3	SCALE	SIZE
		2:3	B
DRAWING NUMBER		REVISION	
9630-20-041-E		02	

Rev.	Description	Initiator	Date
-	See Sheet1	-	-

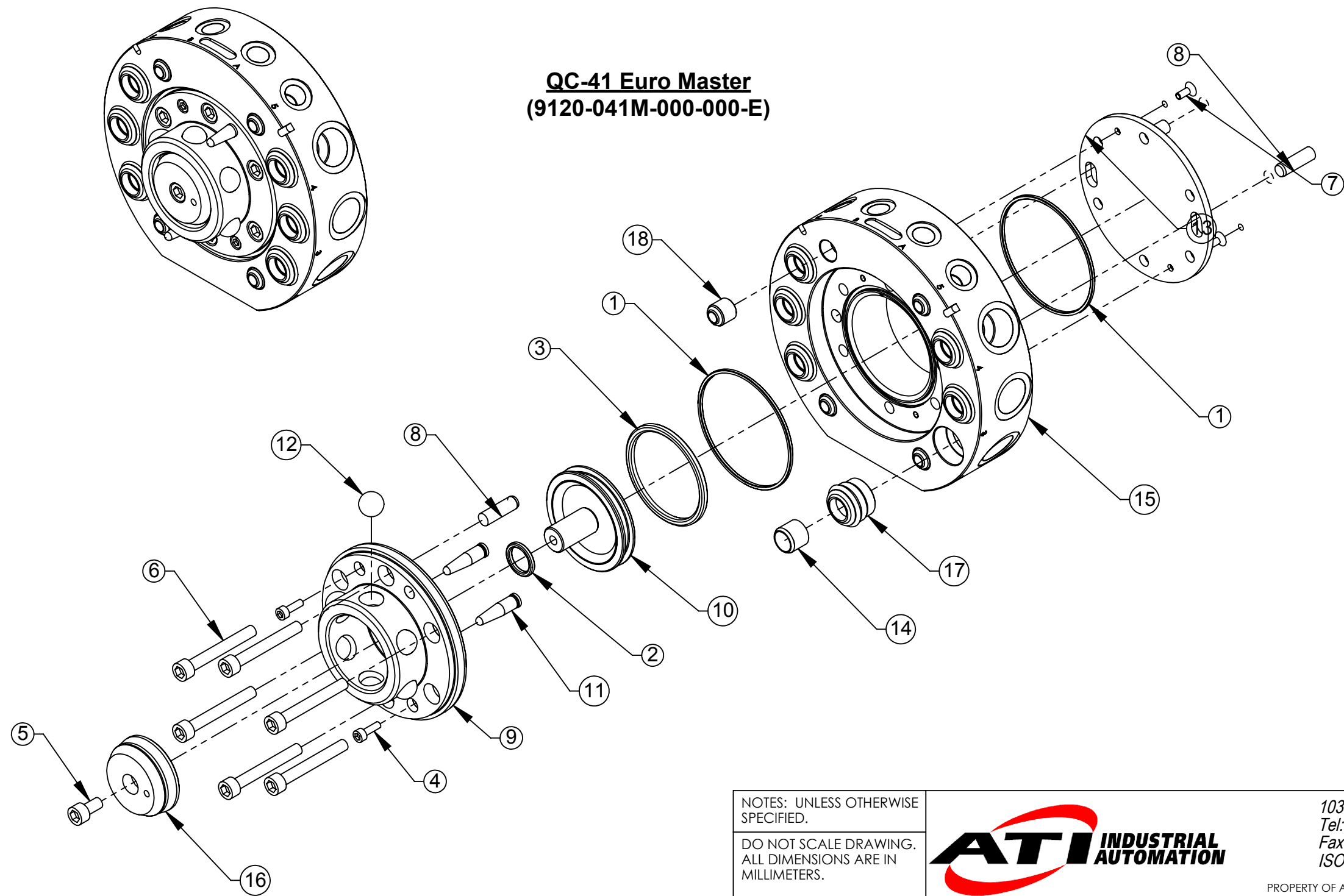

**QC-41 Euro Master
(9120-041M-000-000-E)**

NOTES: UNLESS OTHERWISE SPECIFIED.

DO NOT SCALE DRAWING. ALL DIMENSIONS ARE IN MILLIMETERS.

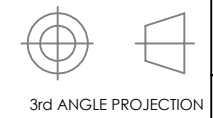

1031 Goodworth Drive, Apex, NC 27539, USA
 Tel: +1.919.772.0115 Email: info@ati-ia.com
 Fax: +1.919.772.8259 www.ati-ia.com
 ISO 9001 Registered Company

PROPERTY OF ATI INDUSTRIAL AUTOMATION, INC. NOT TO BE REPRODUCED IN ANY MANNER EXCEPT ON ORDER OR WITH PRIOR WRITTEN AUTHORIZATION OF ATI.

DRAWN BY: D. Swanson 11/6/15		TITLE	
CHECKED BY: D. Wagner 11/10/15		QC-41 Euro	
PROJECT # -	SHEET 2 OF 3	SCALE 1:2	SIZE B
		DRAWING NUMBER 9630-20-041-E	REVISION 02

Rev.	Description	Initiator	Date
-	See Sheet1	-	-

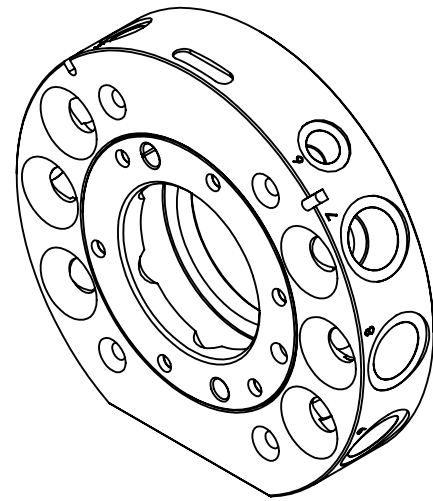

QC-41 Euro Tool
(9120-041T-000-000-E)

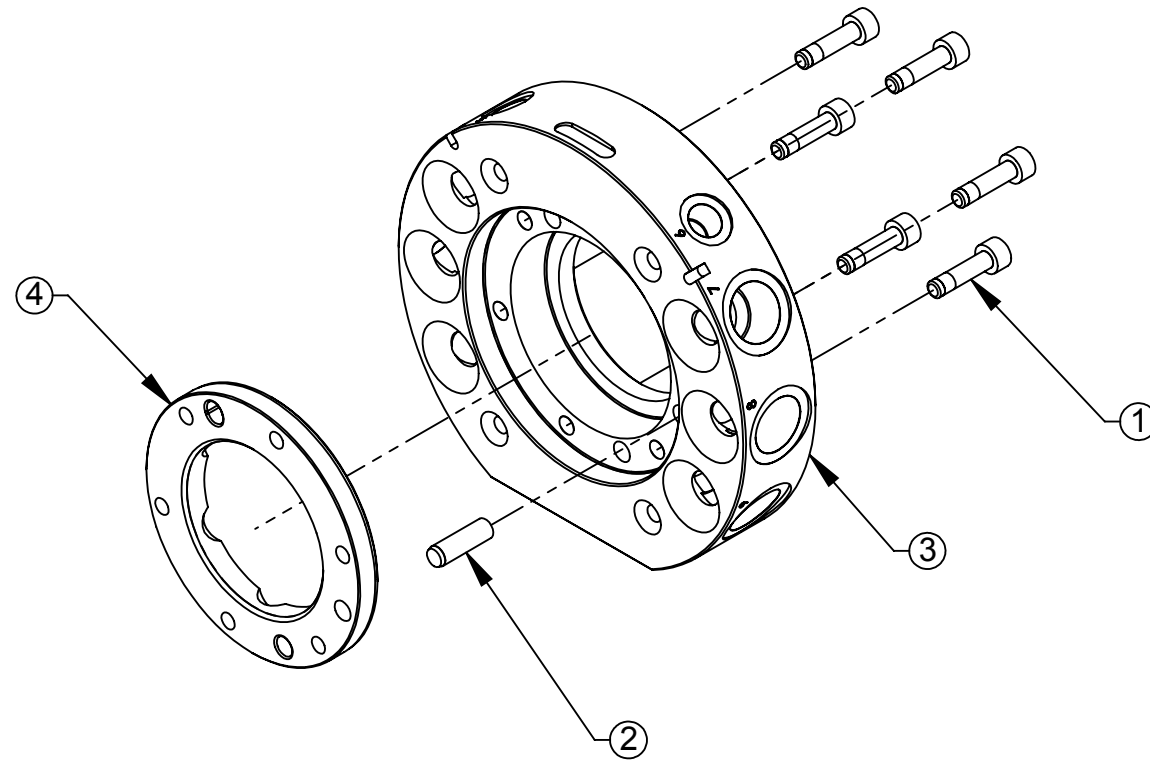

NOTES: UNLESS OTHERWISE SPECIFIED.

DO NOT SCALE DRAWING.
ALL DIMENSIONS ARE IN MILLIMETERS.

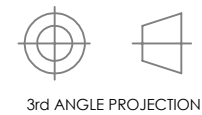

1031 Goodworth Drive, Apex, NC 27539, USA
Tel: +1.919.772.0115 Email: info@ati-ia.com
Fax: +1.919.772.8259 www.ati-ia.com
ISO 9001 Registered Company

PROPERTY OF ATI INDUSTRIAL AUTOMATION, INC. NOT TO BE REPRODUCED IN ANY MANNER EXCEPT ON ORDER OR WITH PRIOR WRITTEN AUTHORIZATION OF ATI.

DRAWN BY: D. Swanson 11/6/15		TITLE	
CHECKED BY: D. Wagner 11/10/15		QC-41 Euro	
PROJECT # -	SHEET 3 OF 3	SCALE	SIZE
		1:2	B
		DRAWING NUMBER	REVISION
		9630-20-041-E	02