

Rev.	Description	Initiator	Date
02	Eco 19304; Release Drawing	CF	9/2/2020

PART NUMBERS:  
 (A) MASTER 9120-020HM-000-PM5-SX-6247  
 (B) TOOL: 9120-020T-000-PM5

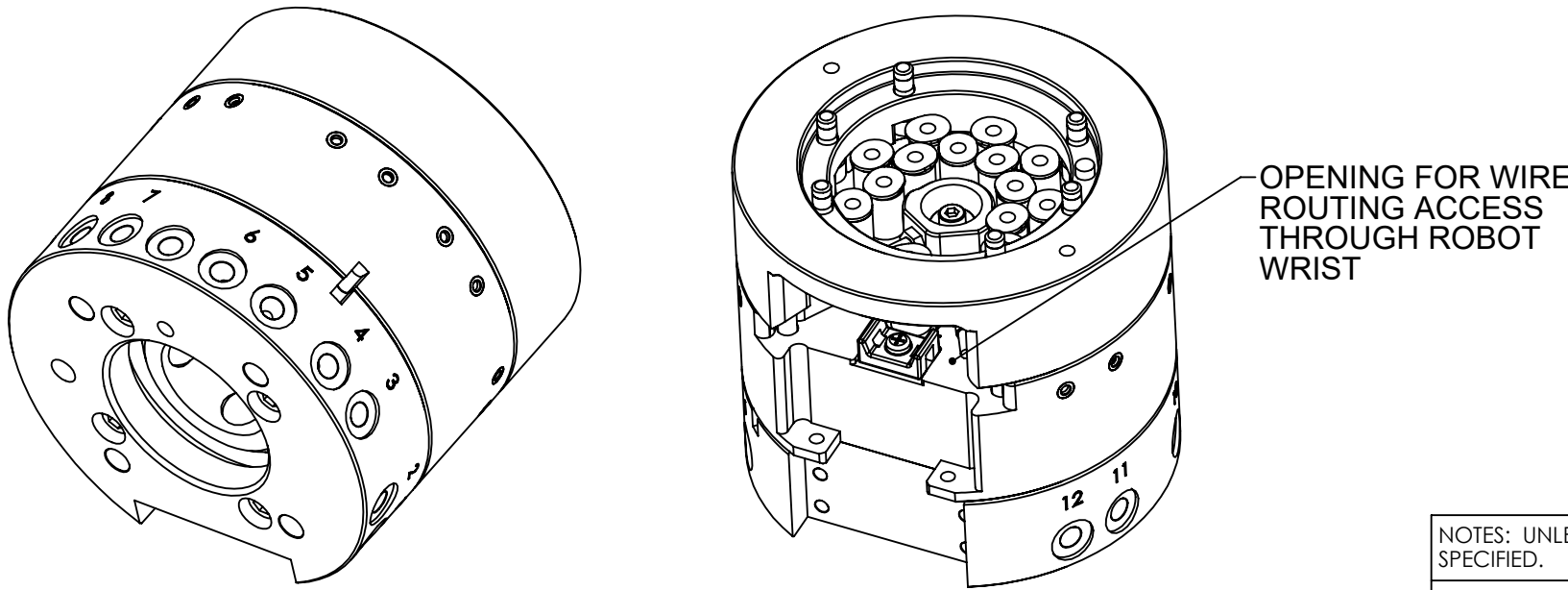
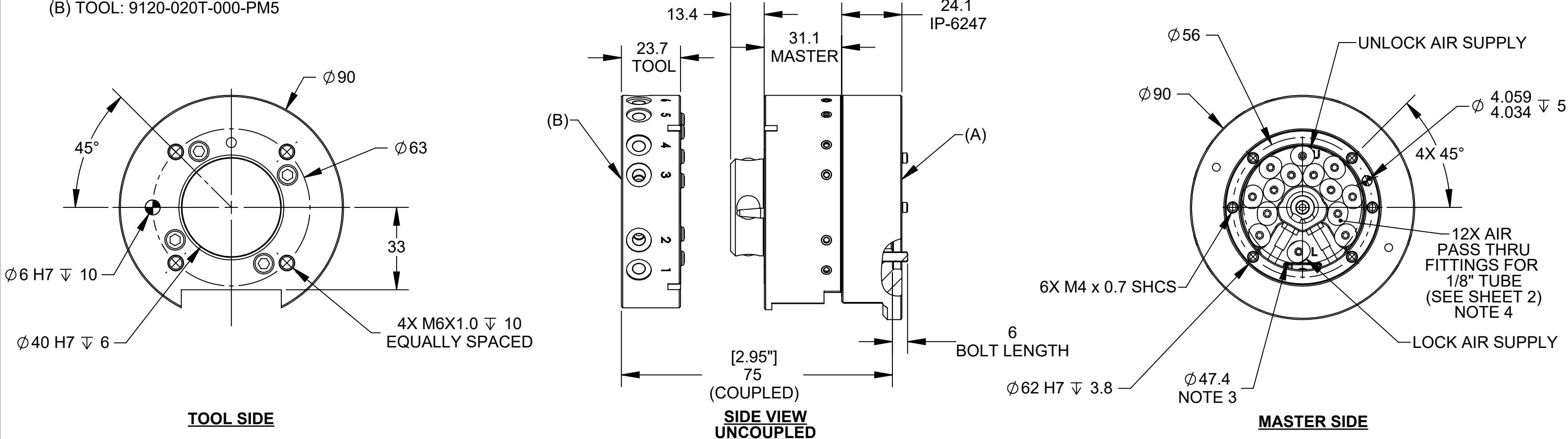

- NOTES:
1. MASTER SIDE MOUNTING HARDWARE PROVIDED.
  2. DRAWING SHOWS A PROPOSED MASTER SIDE ASSEMBLY FOR DIRECT MOUNT TO HOLLOW WRIST ROBOTS.
  3. DIMENSION INDICATES THE PERIMETER FOR PNEUMATIC FITTINGS. COMPONENTS WILL CLEAR THE 50mm HOLLOW WRIST DIMENSION.
  4. TUBE FITTING CONNECTION TO MASTER TOOL CHANGER BODY: M6X1.0 TAP  $\nabla 7.62$  VENDOR PN: PISCO POC 1/8-M6M
  5. 'SX' IN THE MASTER PART NUMBER DESIGNATES LOCK/UNLOCK SENSING VARIOUS OPTIONS ARE AVAILABLE
  6. SHOWN WITH IP-6247 INTERFACE PLATE, IP'S FOR OTHER PATTERNS AVAILABLE UPON REQUEST.
  7. CONTACT ATI FOR FULL PART NUMBERS AND LIST OF OPTIONS

NOTES: UNLESS OTHERWISE SPECIFIED.				1031 Goodworth Drive, Apex, NC 27539, USA	
DO NOT SCALE DRAWING. ALL DIMENSIONS ARE IN MILLIMETERS.				Tel: +1.919.772.0115 www.ati-ia.com	
		DRAWN BY: D. WAGNER, 7/24/20		TITLE	
		CHECKED BY: T. CARROLL, 8/11/20		QC-20 HOLLOW WRIST MOUNT TOOL CHANGER	
PROJECT # -		SCALE	SIZE	DRAWING NUMBER	REVISION
SHEET 1 OF 4		1:1.5	B	9630-20-020HM	01

PROPERTY OF ATI INDUSTRIAL AUTOMATION, INC. NOT TO BE REPRODUCED IN ANY MANNER EXCEPT ON ORDER OR WITH PRIOR WRITTEN AUTHORIZATION OF ATI.

**Robot Mounting Side**

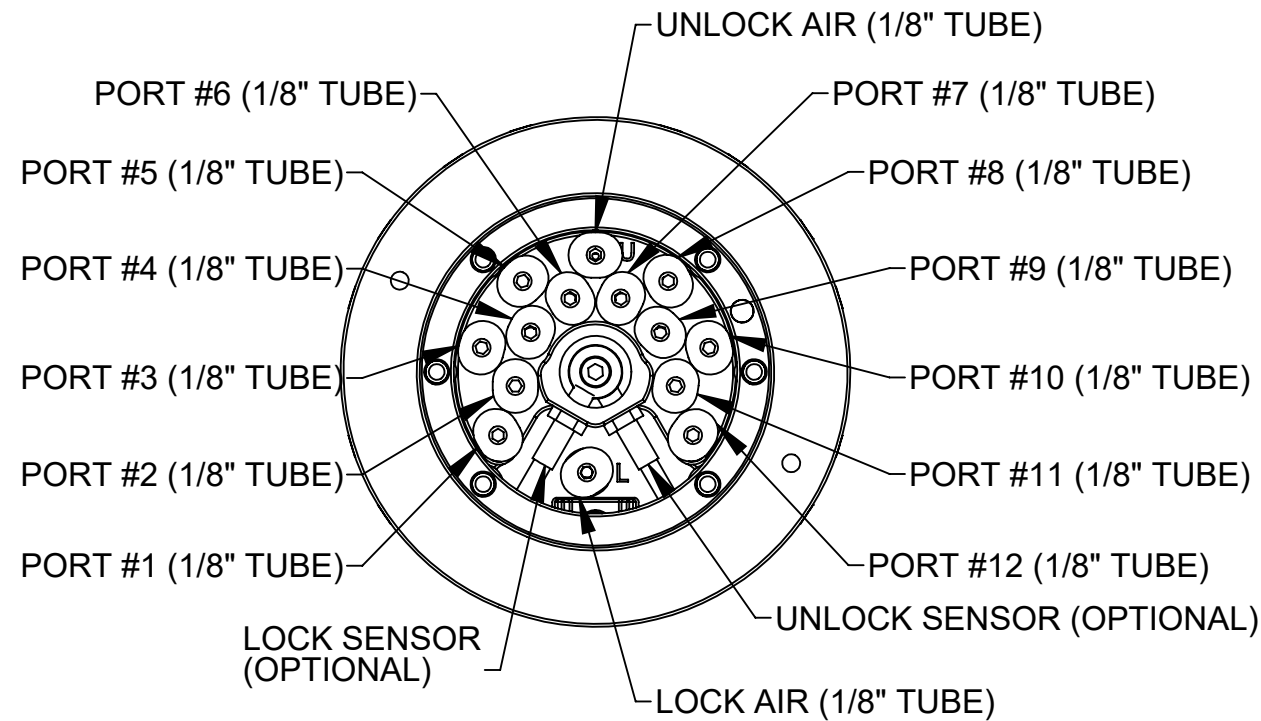

**Master-Tool Coupling Side**

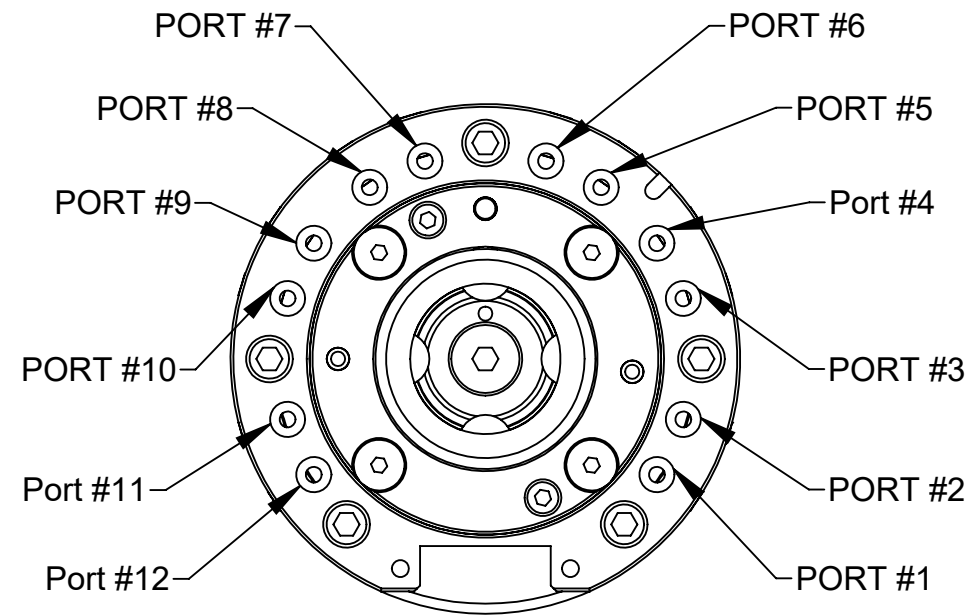

**AIR LINE CONNECTION DIAGRAM**

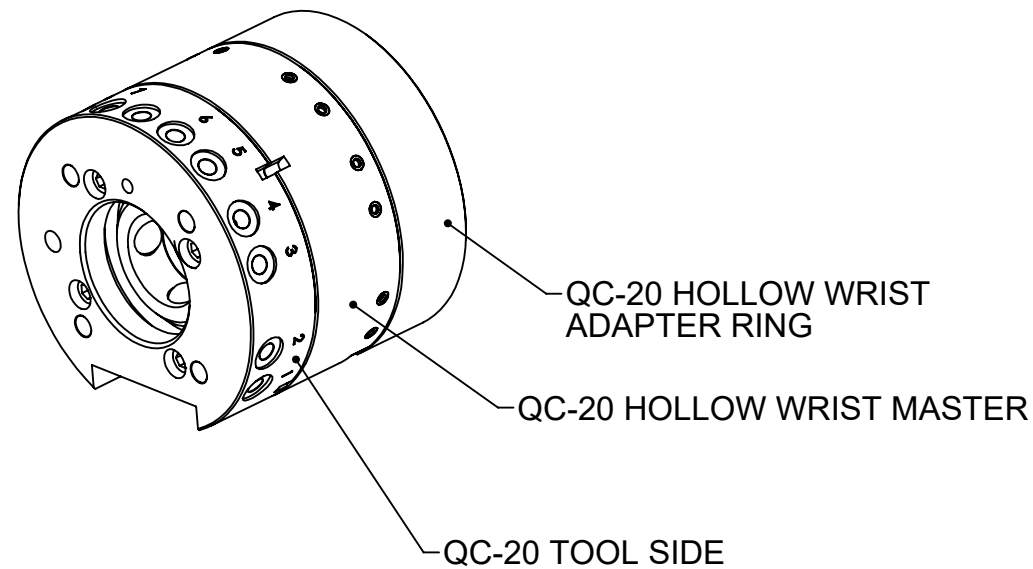

**EXPLODED VIEW**

OPTIONAL UNLOCK STATUS PROX SENSOR

CABLE WILL BE SECURED HERE FOR STRAIN RELIEF

MODULE MOUNTING FLAT FOR OPTIONAL ELECTRICAL SIGNAL PASS-THROUGH

OPTIONAL LOCK STATUS PROX SENSOR

**MASTER ASSY TOP VIEW**

CABLE WILL BE SECURED HERE FOR STRAIN RELIEF

NOTES: UNLESS OTHERWISE SPECIFIED.

DO NOT SCALE DRAWING. ALL DIMENSIONS ARE IN MILLIMETERS.



3rd ANGLE PROJECTION



1031 Goodworth Drive, Apex, NC 27539, USA  
 Tel: +1.919.772.0115 www.ati-ia.com  
 Fax: +1.919.772.8259 ISO 9001 Registered Company

PROPERTY OF ATI INDUSTRIAL AUTOMATION, INC. NOT TO BE REPRODUCED IN ANY MANNER EXCEPT ON ORDER OR WITH PRIOR WRITTEN AUTHORIZATION OF ATI.

DRAWN BY: D. WAGNER, 7/24/20		TITLE	
CHECKED BY: T. CARROLL, 8/11/20		QC-20 HOLLOW WRIST MOUNT TOOL CHANGER	
PROJECT # -	SHEET 2 OF 4	SCALE	REVISION
		1:1.5	01
		SIZE	DRAWING NUMBER
		B	9630-20-020HM

# QC-20HM MASTER ASSEMBLY

9120-020HM-000-PM5-SX-6247

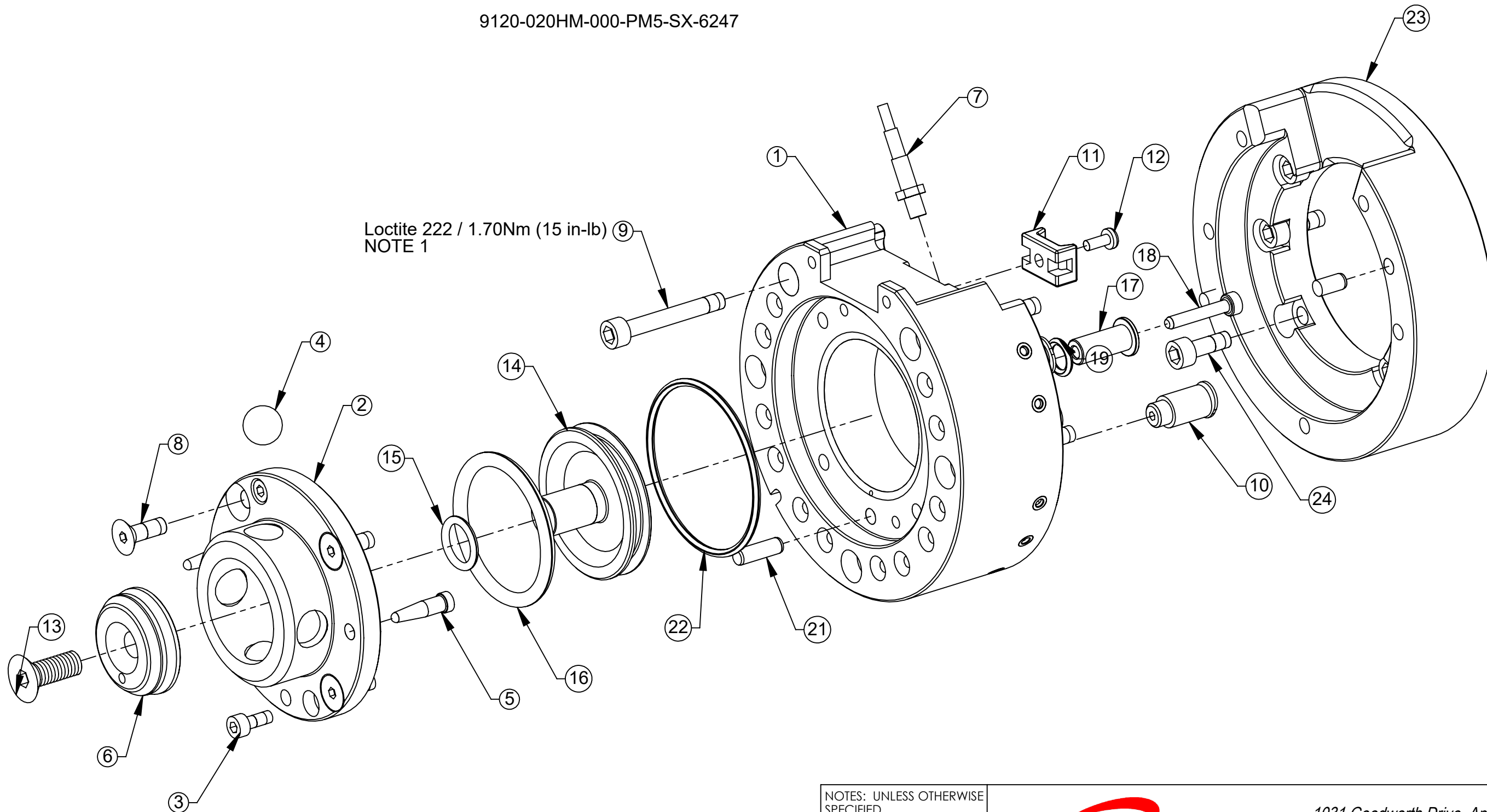

Loctite 222 / 1.70Nm (15 in-lb)  
NOTE 1

NOTES:  
1. ASSEMBLE WITH FASTENERS AS LABELED

NOTES: UNLESS OTHERWISE SPECIFIED.

DO NOT SCALE DRAWING.  
ALL DIMENSIONS ARE IN MILLIMETERS.



3rd ANGLE PROJECTION



1031 Goodworth Drive, Apex, NC 27539, USA  
Tel: +1.919.772.0115 www.ati-ia.com  
Fax: +1.919.772.8259 ISO 9001 Registered Company

PROPERTY OF ATI INDUSTRIAL AUTOMATION, INC. NOT TO BE REPRODUCED IN ANY MANNER EXCEPT ON ORDER OR WITH PRIOR WRITTEN AUTHORIZATION OF ATI.

DRAWN BY: D. WAGNER, 7/24/20		TITLE	
CHECKED BY: T. CARROLL, 8/11/20		QC-20 HOLLOW WRIST MOUNT TOOL CHANGER	
PROJECT # -	SHEET 3 OF 4	SCALE	REVISION
		1:1	01
		SIZE	DRAWING NUMBER
		B	9630-20-020HM

# QC-20 TOOL ASSEMBLY

9120-020T-000-PM5

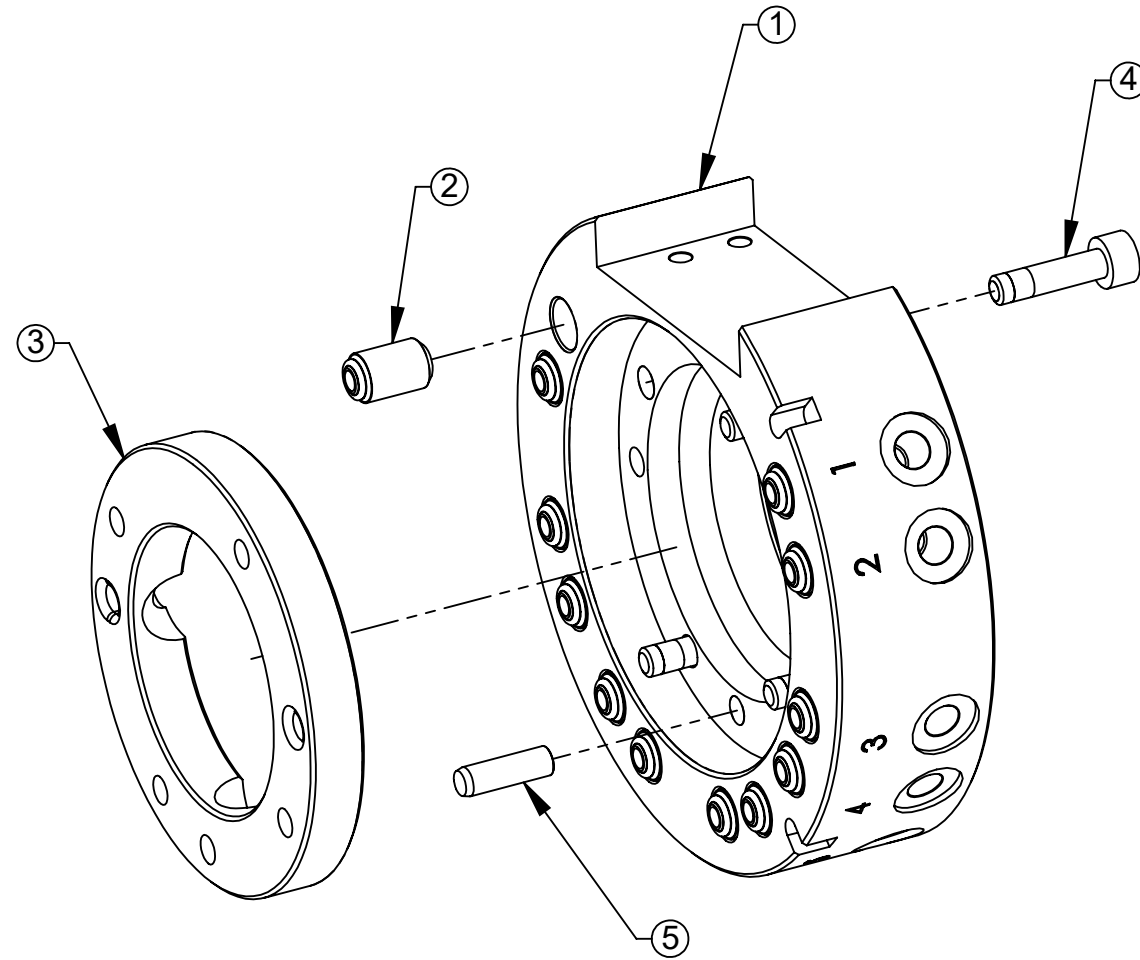

NOTES: UNLESS OTHERWISE SPECIFIED.

DO NOT SCALE DRAWING. ALL DIMENSIONS ARE IN MILLIMETERS.

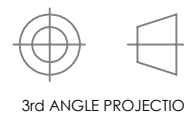

1031 Goodworth Drive, Apex, NC 27539, USA  
 Tel: +1.919.772.0115 [www.ati-ia.com](http://www.ati-ia.com)  
 Fax: +1.919.772.8259 ISO 9001 Registered Company

PROPERTY OF ATI INDUSTRIAL AUTOMATION, INC. NOT TO BE REPRODUCED IN ANY MANNER EXCEPT ON ORDER OR WITH PRIOR WRITTEN AUTHORIZATION OF ATI.

DRAWN BY: D. WAGNER, 7/24/20		TITLE		
CHECKED BY: T. CARROLL, 8/11/20		QC-20 HOLLOW WRIST MOUNT TOOL CHANGER		
PROJECT # -	SHEET 4 OF 4	SCALE	SIZE	DRAWING NUMBER
		1:1	B	9630-20-020HM
				REVISION
				01