

REV.	DESCRIPTION	INITIATOR	DATE
02	Initial Release	SMR	5/22/2018

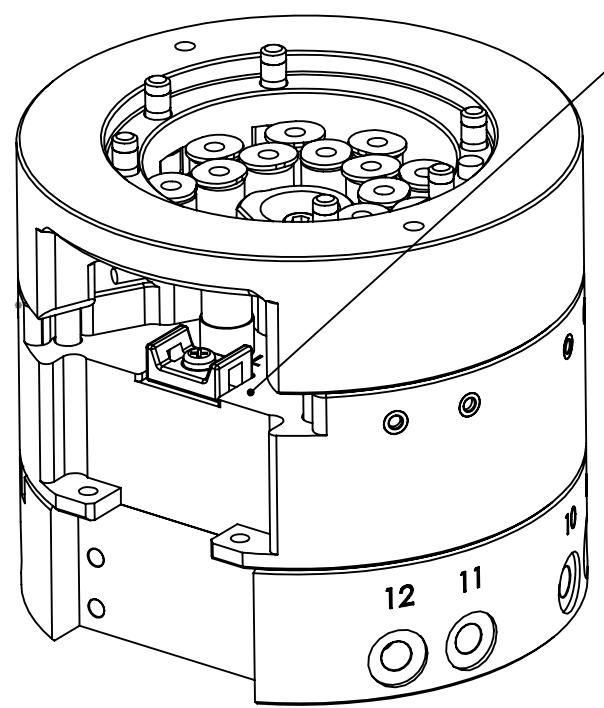
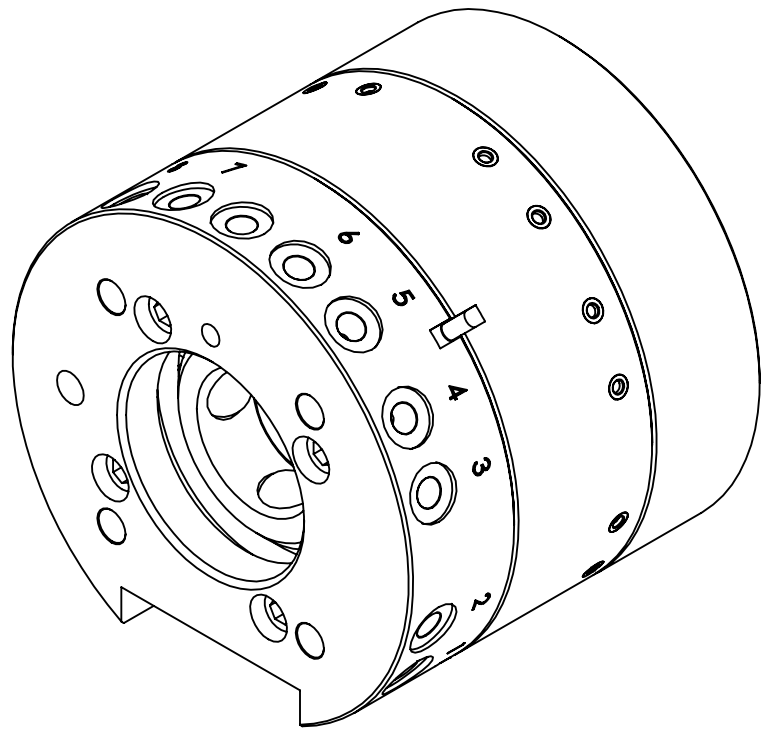
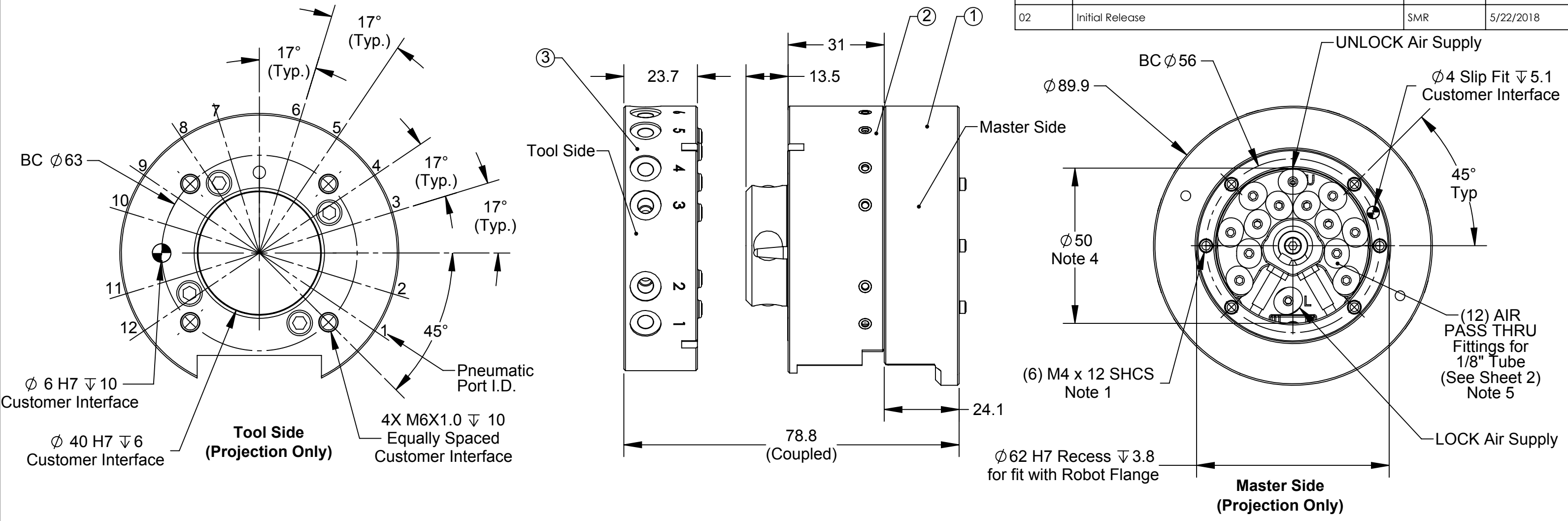

Opening for wire routing access through Robot Wrist

- Notes:
1. Mounting Hardware Included on Master Side
  2. Drawing shows a master side assembly for direct mount to Hollow Wrist Robots.
  3. Tool Side QC-20 is standard product.
  4. Dimension Indicates the perimeter for pneumatic fittings.
  5. Tube fitting connection to Master Tool Changer body: M6x1.0 Tap  $\nabla 7.62$  Vendor PN: Pisco POC 1/8-M6M

ITEM NO.	QTY	PART NUMBER	DESCRIPTION
1	1	9005-20-1634	Adapter Plate Assy, Master Adapter Plate, QC-20HM
2	1	9120-020HM-000-PM5-SQN	QC-20 Hollow Wrist Base Assembly with NPN Sensors
3	1	9120-020T-000-PM5	QC-20 Tool Assembly, 12 Port No Options

NOTES: UNLESS OTHERWISE SPECIFIED.  
DO NOT SCALE DRAWING. ALL DIMENSIONS ARE IN MILLIMETERS.



1031 Goodworth Drive, Apex, NC 27539, USA  
Tel: +1.919.772.0115 Email: info@ati-ia.com  
Fax: +1.919.772.8259 www.ati-ia.com  
ISO 9001 Registered Company

PROPERTY OF ATI INDUSTRIAL AUTOMATION, INC. NOT TO BE REPRODUCED IN ANY MANNER EXCEPT ON ORDER OR WITH PRIOR WRITTEN AUTHORIZATION OF ATI.

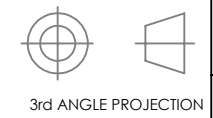

DRAWN BY: S. Roth 5/18/18		TITLE	
CHECKED BY: M. Gala 6/4/2018		QC-20HM-000-PM5-SQN-6247 Customer Drawing	
PROJECT #	180514-2	SHEET	1 OF 5
SCALE	1:1.2	SIZE	B
DRAWING NUMBER	9630-20-020HM 020T		REVISION
			02

**Robot Mounting Side  
(Projection Only)**

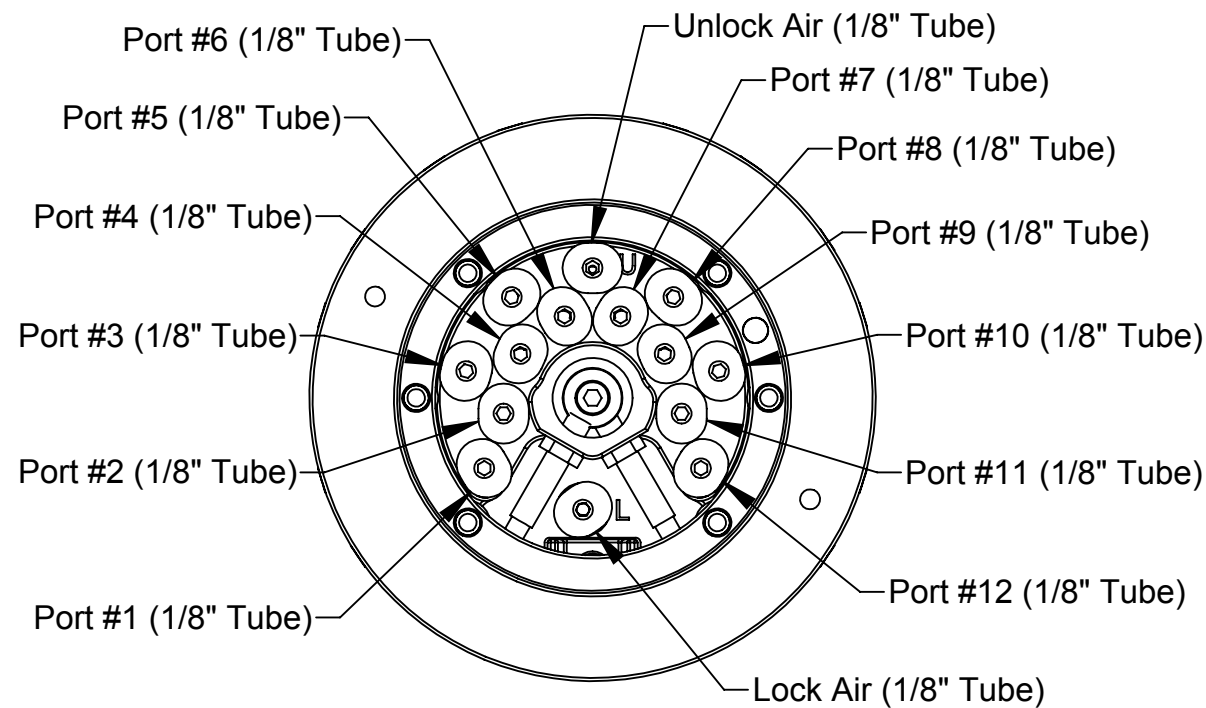

**Master-Tool Coupling Side  
(Projection Only)**

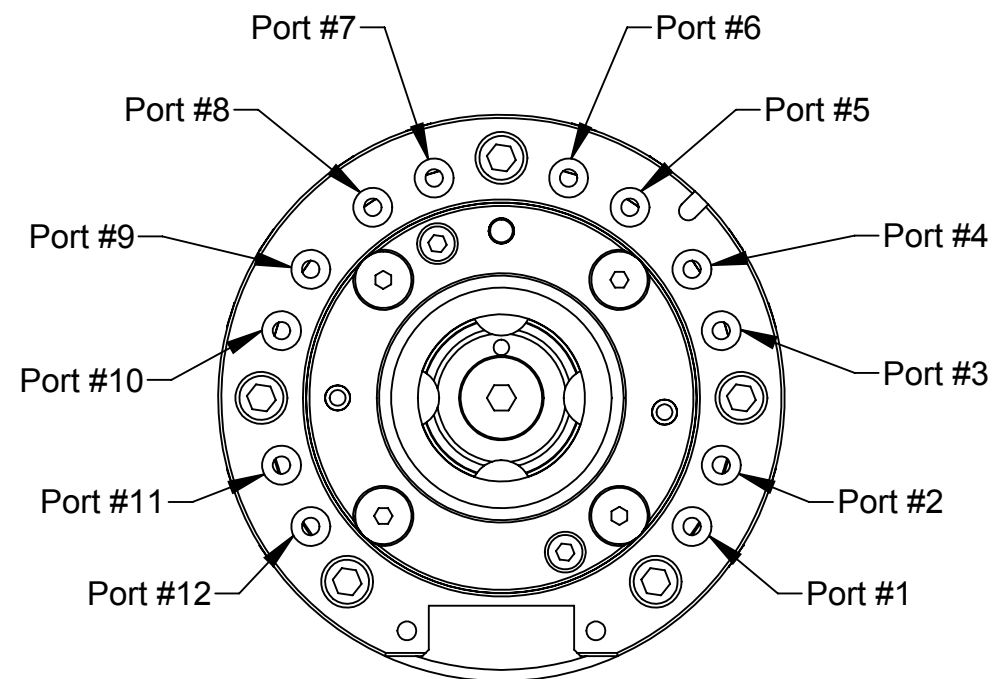

**AIR LINE CONNECTION DIAGRAM**

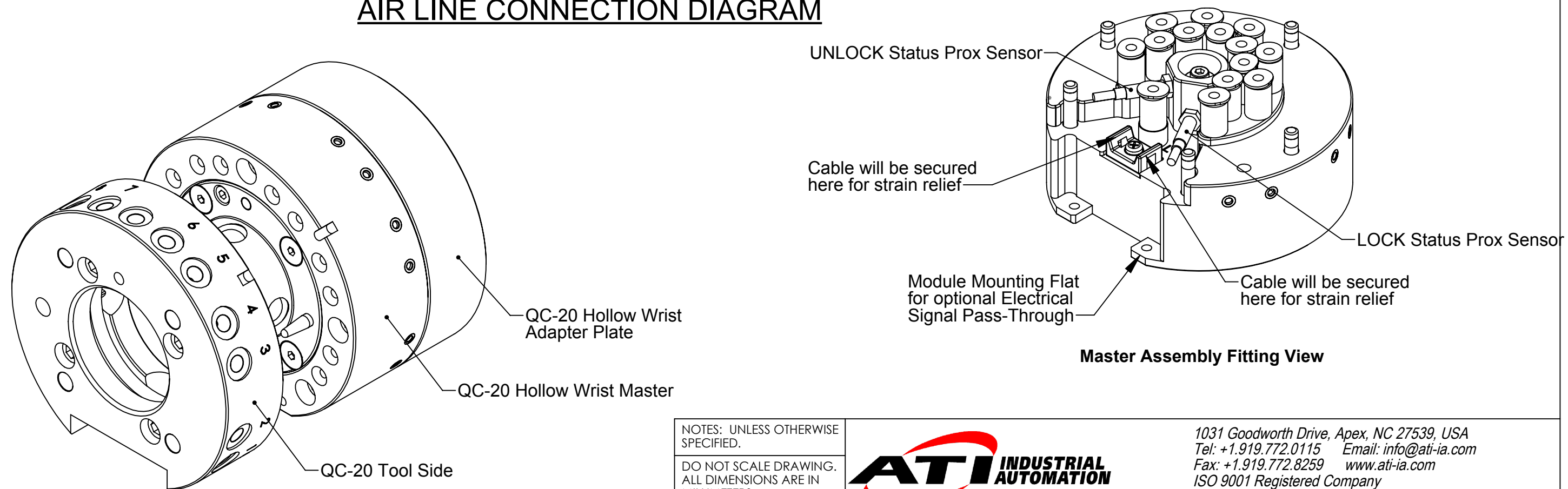

NOTES: UNLESS OTHERWISE SPECIFIED.

DO NOT SCALE DRAWING. ALL DIMENSIONS ARE IN MILLIMETERS.



3rd ANGLE PROJECTION



1031 Goodworth Drive, Apex, NC 27539, USA  
 Tel: +1.919.772.0115 Email: info@ati-ia.com  
 Fax: +1.919.772.8259 www.ati-ia.com  
 ISO 9001 Registered Company

PROPERTY OF ATI INDUSTRIAL AUTOMATION, INC. NOT TO BE REPRODUCED IN ANY MANNER EXCEPT ON ORDER OR WITH PRIOR WRITTEN AUTHORIZATION OF ATI.

DRAWN BY: S. Roth 5/18/18		TITLE	
CHECKED BY: M. Gala 6/4/2018		QC-20HM-000-PM5-SQN-6247 Customer Drawing	
PROJECT #	180514-2	SHEET	2 OF 5
SCALE	1:1.2	SIZE	B
DRAWING NUMBER	9630-20-020HM 020T		REVISION
			02

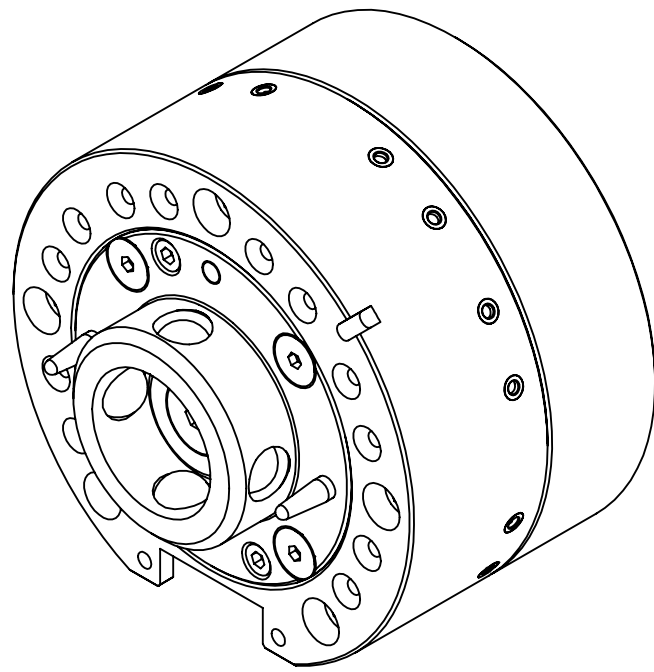

**QC-20HM-000-PM5-SQN-6247 MASTER ASSEMBLY**

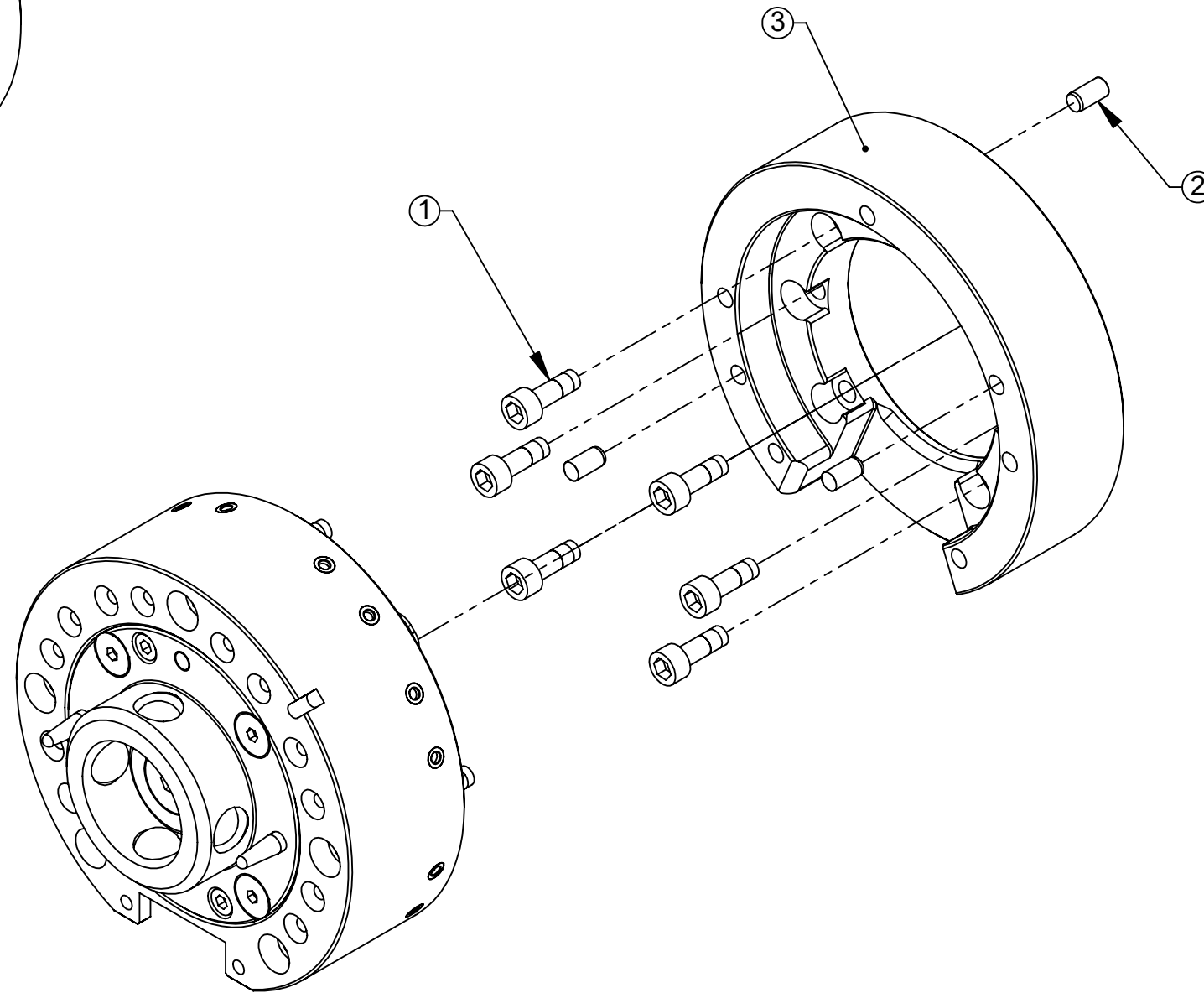

NOTES: UNLESS OTHERWISE SPECIFIED.

DO NOT SCALE DRAWING. ALL DIMENSIONS ARE IN MILLIMETERS.



3rd ANGLE PROJECTION



1031 Goodworth Drive, Apex, NC 27539, USA  
 Tel: +1.919.772.0115 Email: info@ati-ia.com  
 Fax: +1.919.772.8259 www.ati-ia.com  
 ISO 9001 Registered Company

PROPERTY OF ATI INDUSTRIAL AUTOMATION, INC. NOT TO BE REPRODUCED IN ANY MANNER EXCEPT ON ORDER OR WITH PRIOR WRITTEN AUTHORIZATION OF ATI.

DRAWN BY: S. Roth 5/18/18		TITLE	
CHECKED BY: M. Gala 6/4/2018		QC-20HM-000-PM5-SQN-6247 Customer Drawing	
PROJECT # 180514-2	SHEET 3 OF 5	SCALE 1:1.2	REVISION 02
		SIZE B	DRAWING NUMBER 9630-20-020HM 020T

# QC-20HM-000-PM5-SQN MASTER ASSEMBLY

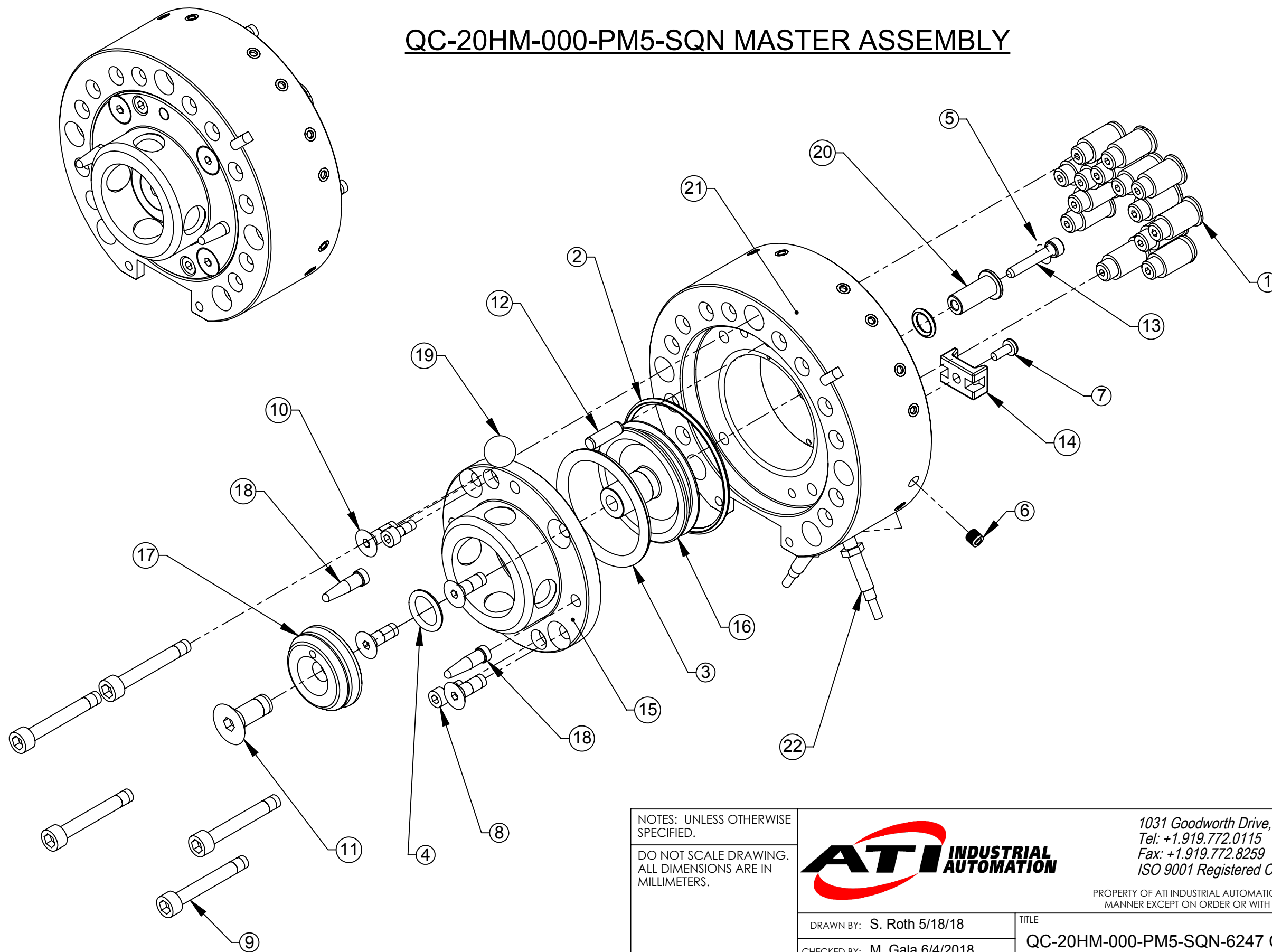

NOTES: UNLESS OTHERWISE SPECIFIED.

DO NOT SCALE DRAWING. ALL DIMENSIONS ARE IN MILLIMETERS.

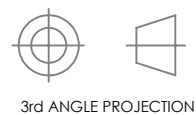

		1031 Goodworth Drive, Apex, NC 27539, USA Tel: +1.919.772.0115 Email: info@ati-ia.com Fax: +1.919.772.8259 www.ati-ia.com ISO 9001 Registered Company		
		PROPERTY OF ATI INDUSTRIAL AUTOMATION, INC. NOT TO BE REPRODUCED IN ANY MANNER EXCEPT ON ORDER OR WITH PRIOR WRITTEN AUTHORIZATION OF ATI.		
DRAWN BY: S. Roth 5/18/18	CHECKED BY: M. Gala 6/4/2018	TITLE QC-20HM-000-PM5-SQN-6247 Customer Drawing		
PROJECT # 180514-2 SHEET 4 OF 5	SCALE 1:1.2	SIZE B	DRAWING NUMBER 9630-20-020HM 020T	REVISION 02

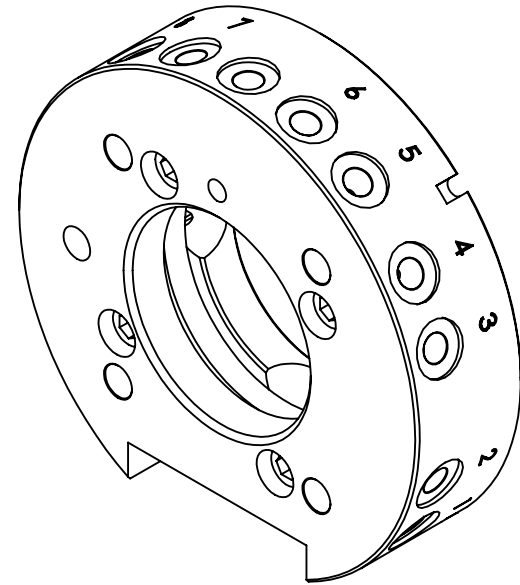

## QC-20 TOOL ASSEMBLY

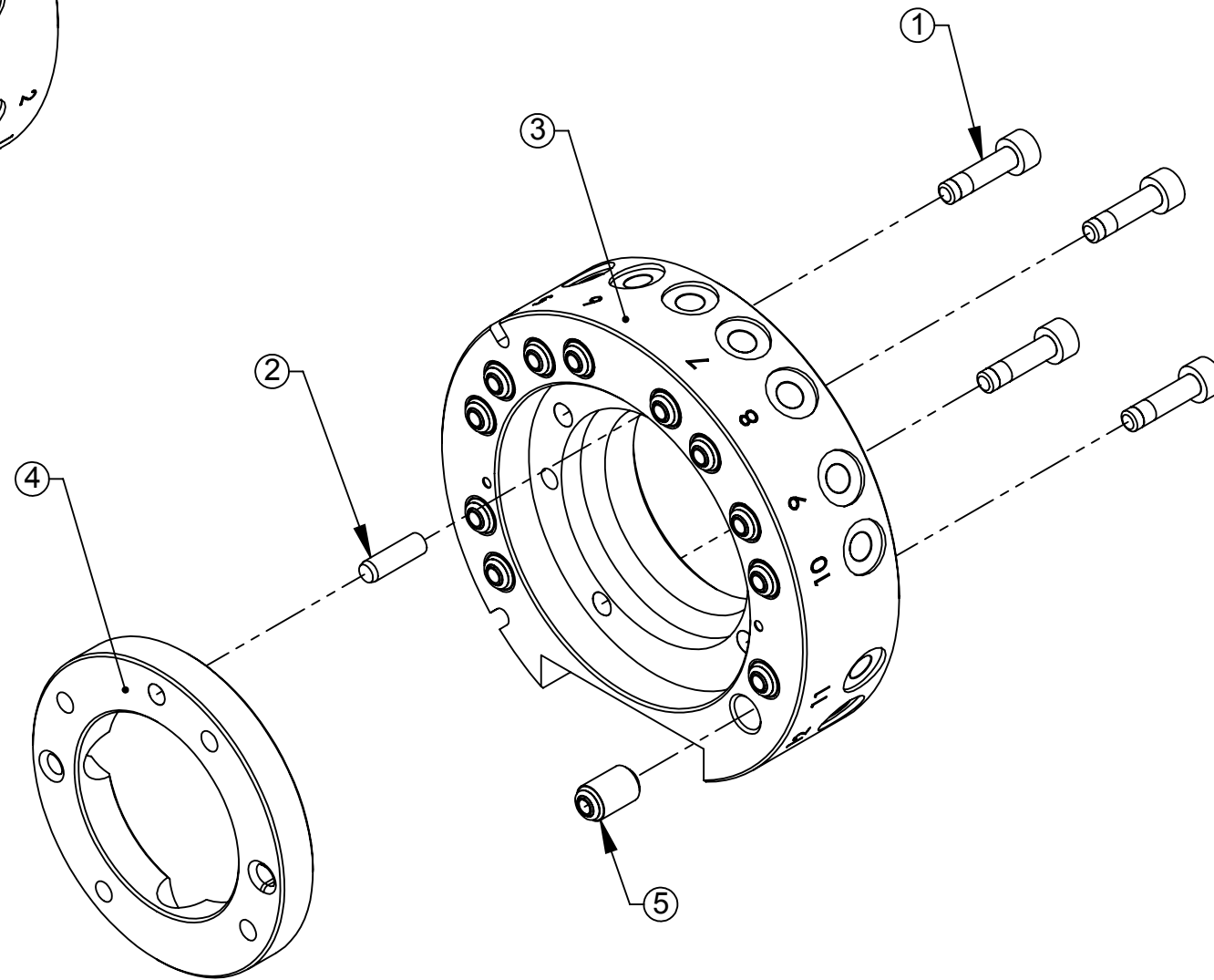

NOTES: UNLESS OTHERWISE SPECIFIED.

DO NOT SCALE DRAWING.  
ALL DIMENSIONS ARE IN MILLIMETERS.



3rd ANGLE PROJECTION



1031 Goodworth Drive, Apex, NC 27539, USA  
Tel: +1.919.772.0115 Email: info@ati-ia.com  
Fax: +1.919.772.8259 www.ati-ia.com  
ISO 9001 Registered Company

PROPERTY OF ATI INDUSTRIAL AUTOMATION, INC. NOT TO BE REPRODUCED IN ANY MANNER EXCEPT ON ORDER OR WITH PRIOR WRITTEN AUTHORIZATION OF ATI.

DRAWN BY: S. Roth 5/18/18		TITLE	
CHECKED BY: M. Gala 6/4/2018		QC-20HM-000-PM5-SQN-6247 Customer Drawing	
PROJECT #	180514-2	SHEET	5 OF 5
SCALE	1:1.2	SIZE	B
DRAWING NUMBER	9630-20-020HM 020T		REVISION
			02