

PART NUMBERS:
 (A) MASTER 9120-011HM-000-000-SX-1660
 (B) TOOL: 9120-011T-000-000

Rev.	Description	Initiator	Date
02	Eco 19304; Release Drawing	CF	9/2/2020

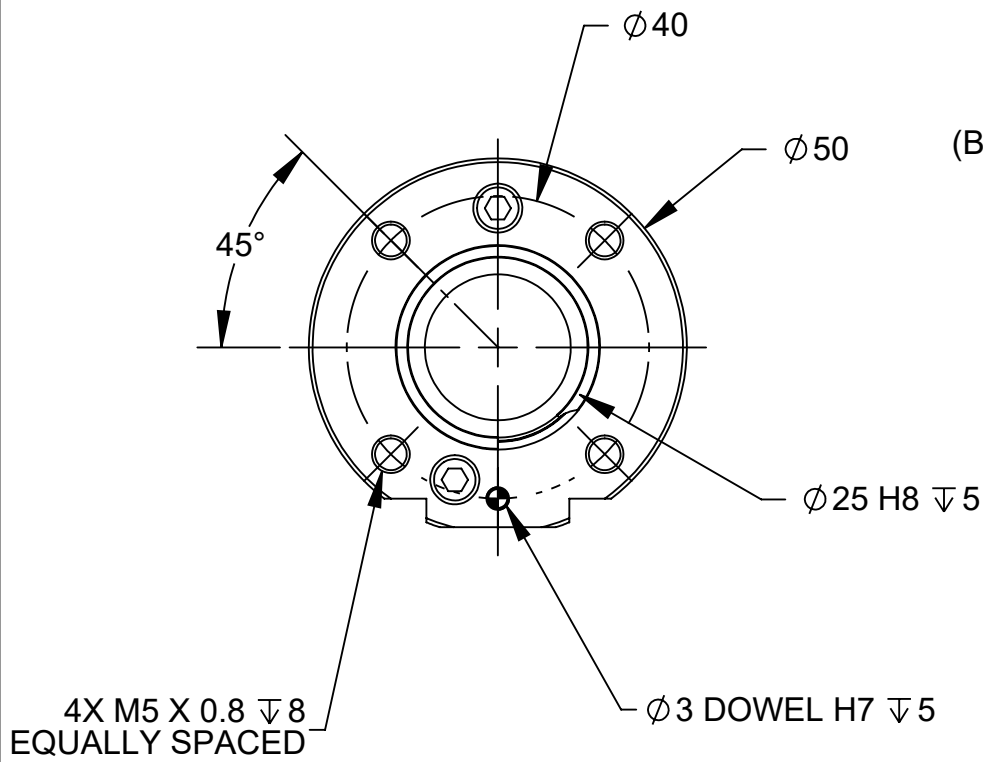

TOOL SIDE

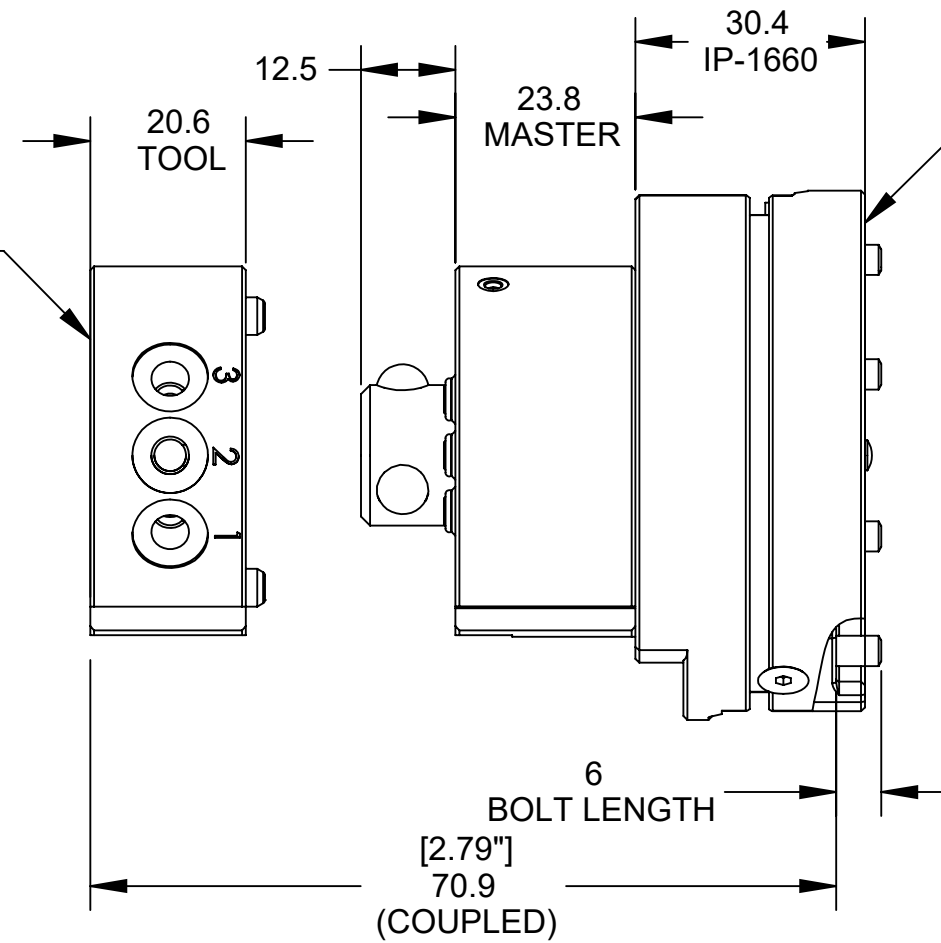

SIDE VIEW (UNCOUPLD)

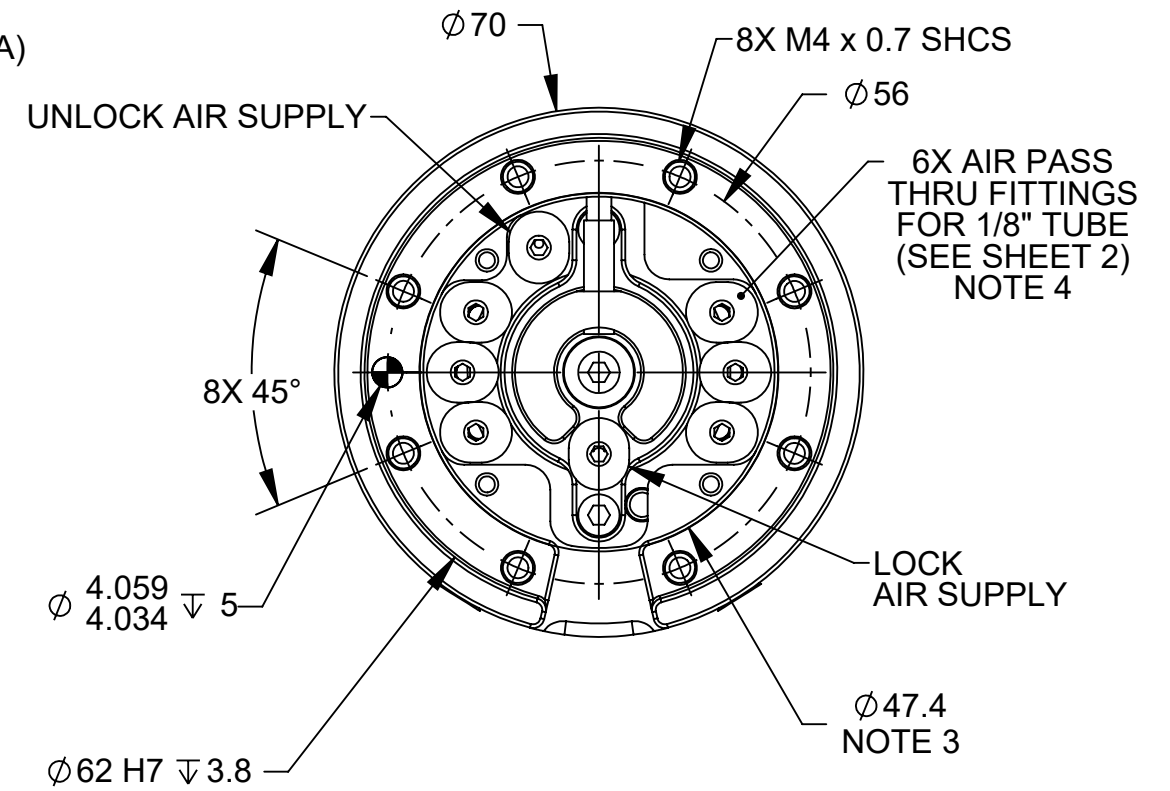

MASTER SIDE

NOTES:

1. MASTER SIDE MOUNTING HARDWARE PROVIDED.
2. DRAWING SHOWS A PROPOSED MASTER SIDE ASSEMBLY FOR DIRECT MOUNT TO FANUC M10IA AND M20IA HOLLOW WRIST ROBOTS.
3. DIMENSION INDICATES THE PERIMETER FOR PNEUMATIC FITTINGS. COMPONENTS WILL CLEAR THE 50mm HOLLOW WRIST DIMENSION.
4. TUBE FITTING CONNECTION TO MASTER TOOL CHANGER BODY: M6X1.0 TAP ∇ 4.45 VENDOR PN: PISCO POC 1/8-M6M
5. 'SX' IN THE MASTER PART NUMBER DESIGNATES LOCK/UNLOCK SENSING VARIOUS OPTIONS ARE AVAILABLE
6. SHOWN WITH IP-1660 INTERFACE PLATE, IP'S FOR OTHER PATTERNS AVAILABLE UPON REQUEST.
7. CONTACT ATI FOR FULL PART NUMBERS AND LIST OF OPTIONS.

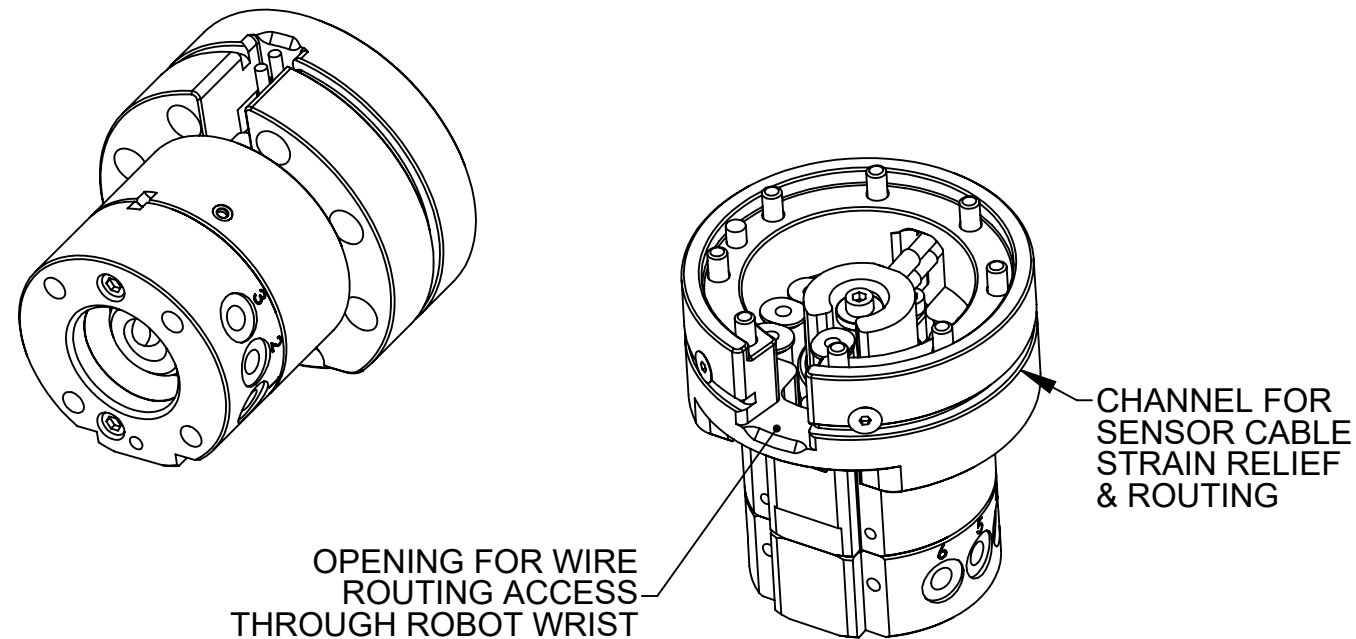

NOTES: UNLESS OTHERWISE SPECIFIED.

DO NOT SCALE DRAWING. ALL DIMENSIONS ARE IN MILLIMETERS.



3rd ANGLE PROJECTION



1031 Goodworth Drive, Apex, NC 27539, USA
 Tel: +1.919.772.0115 Email: info@ati-ia.com
 Fax: +1.919.772.8259 www.ati-ia.com
 ISO 9001 Registered Company

PROPERTY OF ATI INDUSTRIAL AUTOMATION, INC. NOT TO BE REPRODUCED IN ANY MANNER EXCEPT ON ORDER OR WITH PRIOR WRITTEN AUTHORIZATION OF ATI.

DRAWN BY: D. WAGNER, 7/14/20		TITLE	
CHECKED BY: T. CARROLL, 8/11/20		QC-11 HOLLOW WRIST DRAWING	
PROJECT #	SHEET 1 OF 4	SCALE	REVISION
		1:1	01
		SIZE	DRAWING NUMBER
		B	9630-20-011HM

Robot Mounting Side

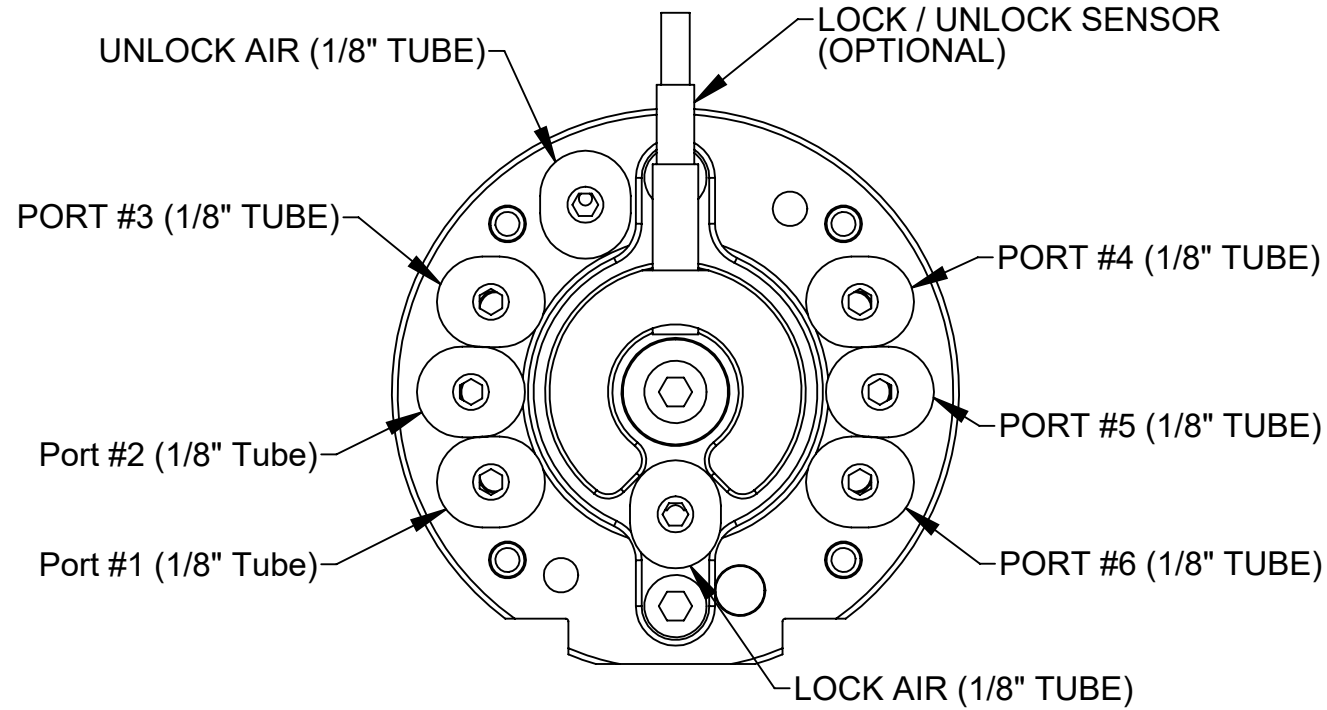

Master-Tool Coupling Side

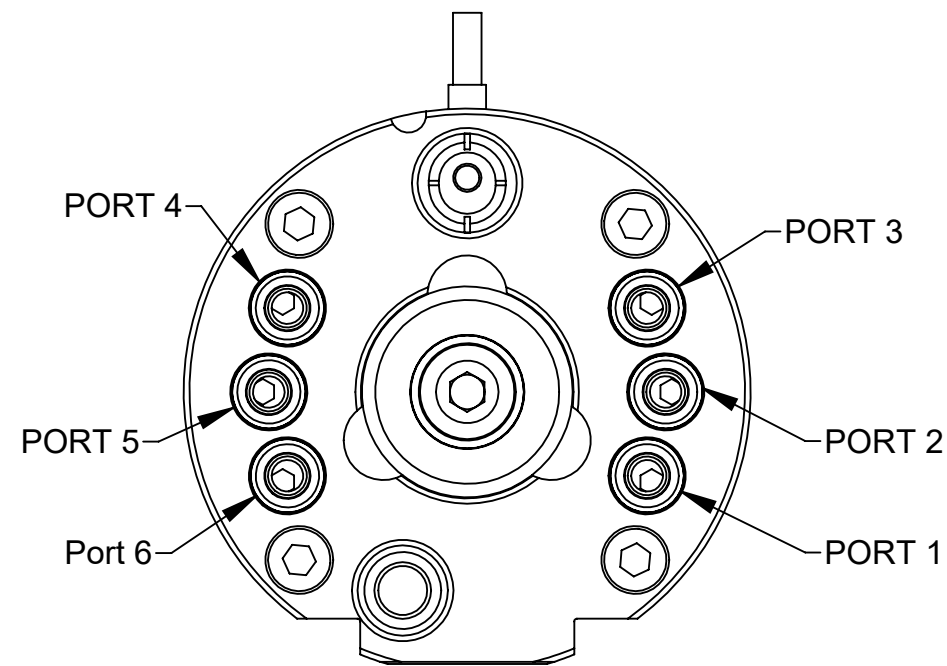

AIR LINE CONNECTION DIAGRAM

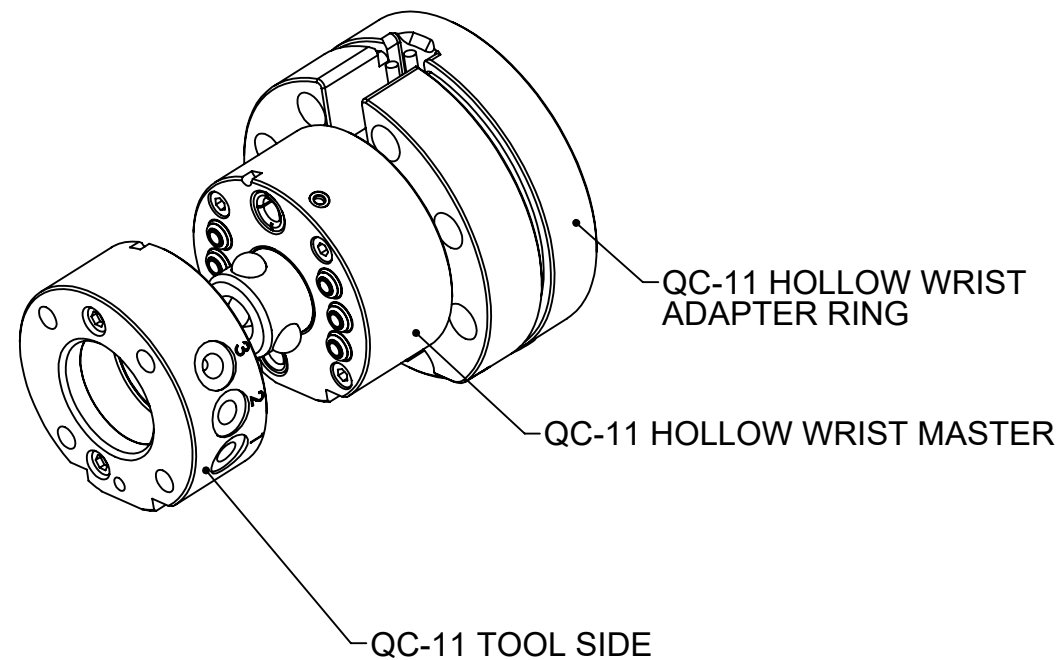

EXPLODED VIEW

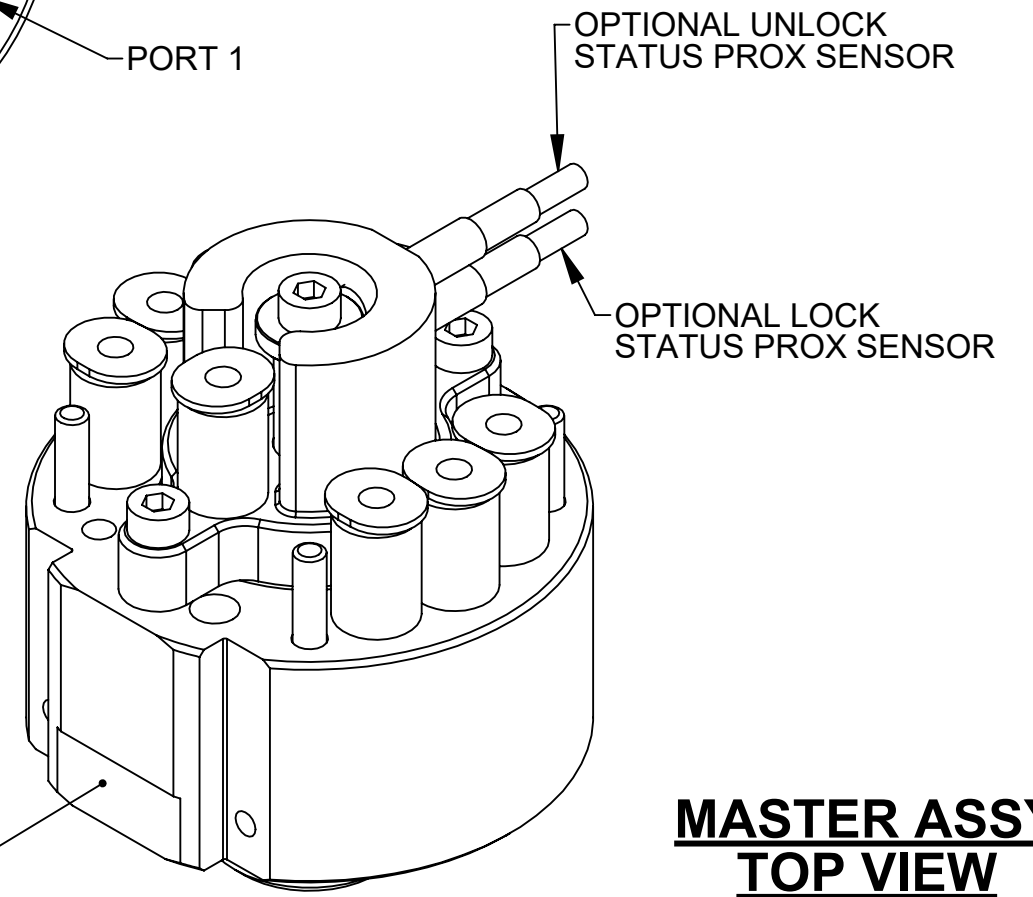

**MASTER ASSY
TOP VIEW**

NOTES: UNLESS OTHERWISE SPECIFIED.

DO NOT SCALE DRAWING. ALL DIMENSIONS ARE IN MILLIMETERS.

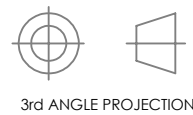

1031 Goodworth Drive, Apex, NC 27539, USA
 Tel: +1.919.772.0115 Email: info@ati-ia.com
 Fax: +1.919.772.8259 www.ati-ia.com
 ISO 9001 Registered Company

PROPERTY OF ATI INDUSTRIAL AUTOMATION, INC. NOT TO BE REPRODUCED IN ANY MANNER EXCEPT ON ORDER OR WITH PRIOR WRITTEN AUTHORIZATION OF ATI.

DRAWN BY: D. WAGNER, 7/14/20		TITLE	
CHECKED BY: T. CARROLL, 8/11/20		QC-11 HOLLOW WRIST DRAWING	
PROJECT #	SHEET 2 OF 4	SCALE	REVISION
		1:1	01
		SIZE	DRAWING NUMBER
		B	9630-20-011HM

QC-11HM MASTER ASSEMBLY

9120-011HM-000-000-SX-1660

Loctite 222 / 1.13Nm (10 in-lb)
NOTE 1

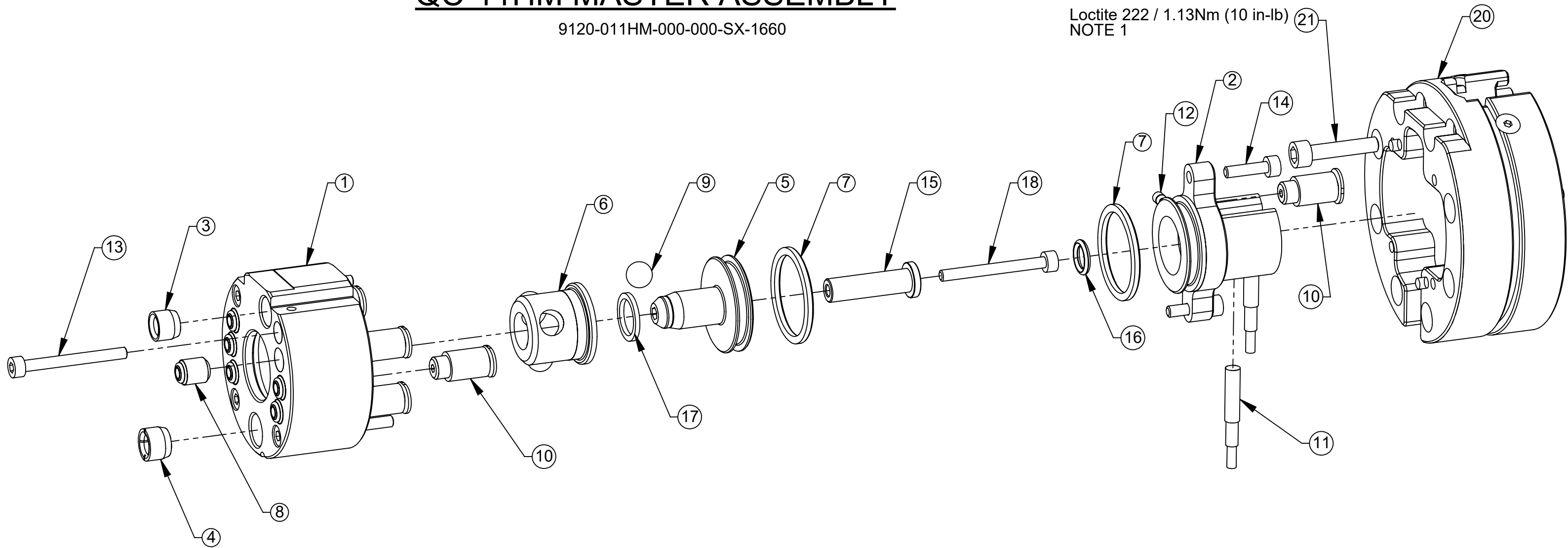

NOTES:
1. ASSEMBLE WITH FASTENERS AS LABELED

NOTES: UNLESS OTHERWISE SPECIFIED.

DO NOT SCALE DRAWING.
ALL DIMENSIONS ARE IN MILLIMETERS.



3rd ANGLE PROJECTION



1031 Goodworth Drive, Apex, NC 27539, USA
Tel: +1.919.772.0115 www.ati-ia.com
Fax: +1.919.772.8259 ISO 9001 Registered Company

PROPERTY OF ATI INDUSTRIAL AUTOMATION, INC. NOT TO BE REPRODUCED IN ANY MANNER EXCEPT ON ORDER OR WITH PRIOR WRITTEN AUTHORIZATION OF ATI.

DRAWN BY: D. WAGNER, 7/14/20

CHECKED BY: T. CARROLL, 8/11/20

TITLE

QC-11 HOLLOW WRIST DRAWING

PROJECT #

SHEET 3 OF 4

SCALE
1:1

SIZE
B

DRAWING NUMBER
9630-20-011HM

REVISION
01

QC-11 TOOL ASSEMBLY

9120-011T-000-000

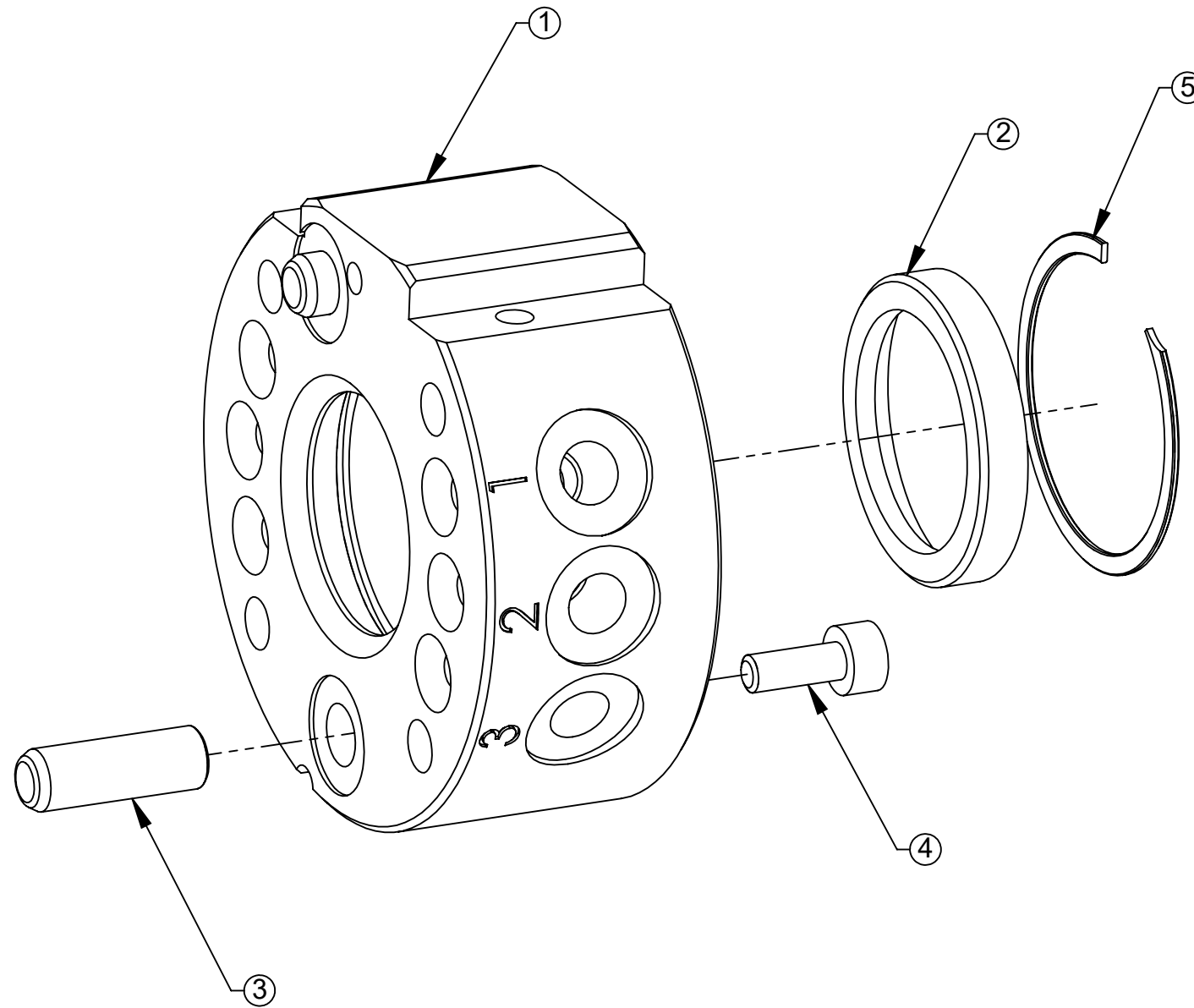

NOTES: UNLESS OTHERWISE SPECIFIED.

DO NOT SCALE DRAWING. ALL DIMENSIONS ARE IN MILLIMETERS.



3rd ANGLE PROJECTION



1031 Goodworth Drive, Apex, NC 27539, USA
 Tel: +1.919.772.0115 www.ati-ia.com
 Fax: +1.919.772.8259 ISO 9001 Registered Company

PROPERTY OF ATI INDUSTRIAL AUTOMATION, INC. NOT TO BE REPRODUCED IN ANY MANNER EXCEPT ON ORDER OR WITH PRIOR WRITTEN AUTHORIZATION OF ATI.

DRAWN BY: D. WAGNER, 7/14/20

CHECKED BY: T. CARROLL, 8/11/20

TITLE

QC-11 HOLLOW WRIST DRAWING

PROJECT #

SHEET 4 OF 4

SCALE
2:1

SIZE
B

DRAWING NUMBER
9630-20-011HM

REVISION
01