

REV.	DESCRIPTION	INITIATOR	DATE
02	INITIAL DRAWING	DAW	6/9/2020

PART NUMBERS:
 (A) MASTER: 9120-011M-000-000
 (B) TOOL: 9120-011T-000-000

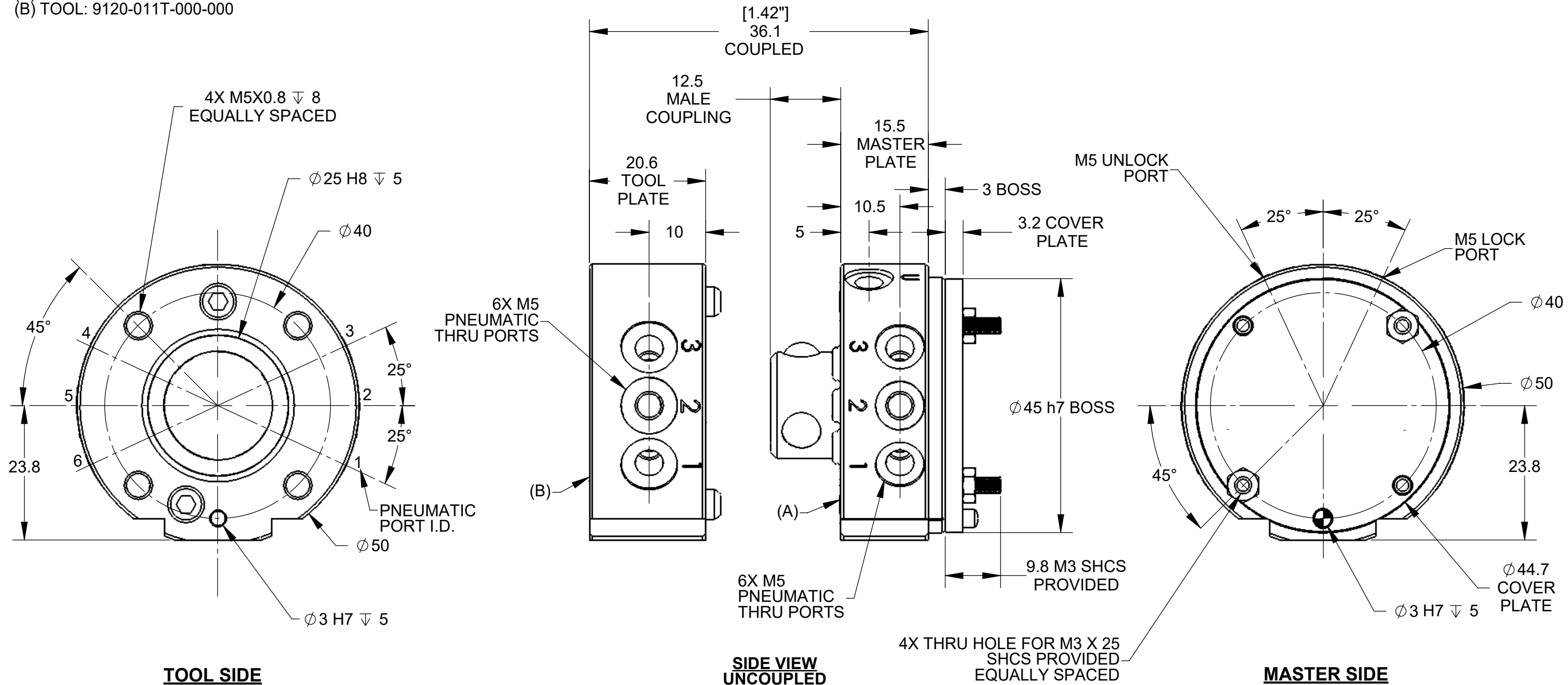

WARNING:
 DO NOT APPLY LOCK/UNLOCK AIR PRESSURE WITHOUT MASTER COVER PLATE PROPERLY ATTACHED. IF COVER PLATE IS NOT USED, MASTER SHOULD BE PROPERLY ATTACHED TO INTERFACE. FAILURE TO DO SO COULD RESULT IN DAMAGE TO COVER PLATE AND O-RING.

- NOTES:**
1. MASTER SIDE MOUNTING HARDWARE PROVIDED.
 2. COVER PLATE IS NOT NECESSARY IF ROBOT INTERFACE PLATE PROVIDES SEALING. THE RECOMMENDED INTERFACE PLATE BORE DEPTH WITHOUT A COVER PLATE IS 2.5MM, WITH A COVER PLATE IS 5.6MM.
 3. ORIENTATION MARKS ARE PROVIDED TO ASSIST IN ROBOT TEACHING.
 4. LOCK/UNLOCK SENSING OPTIONS ARE AVAILABLE
 5. INTERFACE PLATES ARE AVAILABLE TO ADAPT THE TOOL CHANGER TO SPECIFIC MOUNTING PATTERNS
 6. CONTACT ATI FOR FULL PART NUMBERS AND LIST OF OPTIONS

NOTES: UNLESS OTHERWISE SPECIFIED.

DO NOT SCALE DRAWING. ALL DIMENSIONS ARE IN MILLIMETERS.

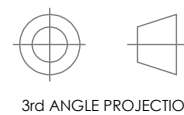

1031 Goodworth Drive, Apex, NC 27539, USA
 Tel: +1.919.772.0115 www.ati-ia.com
 Fax: +1.919.772.8259 ISO 9001 Registered Company

PROPERTY OF ATI INDUSTRIAL AUTOMATION, INC. NOT TO BE REPRODUCED IN ANY MANNER EXCEPT ON ORDER OR WITH PRIOR WRITTEN AUTHORIZATION OF ATI.

DRAWN BY: D. WAGNER 6/9/20

CHECKED BY: T. CARROLL 7/15/20

TITLE

QC-11 TOOL CHANGER DRAWING

PROJECT #

SHEET 1 OF 3

SCALE
1.5:1

SIZE
B

DRAWING NUMBER
9630-20-011

REVISION
02

QC-11 MASTER ASSEMBLY

9120-011M-000-000

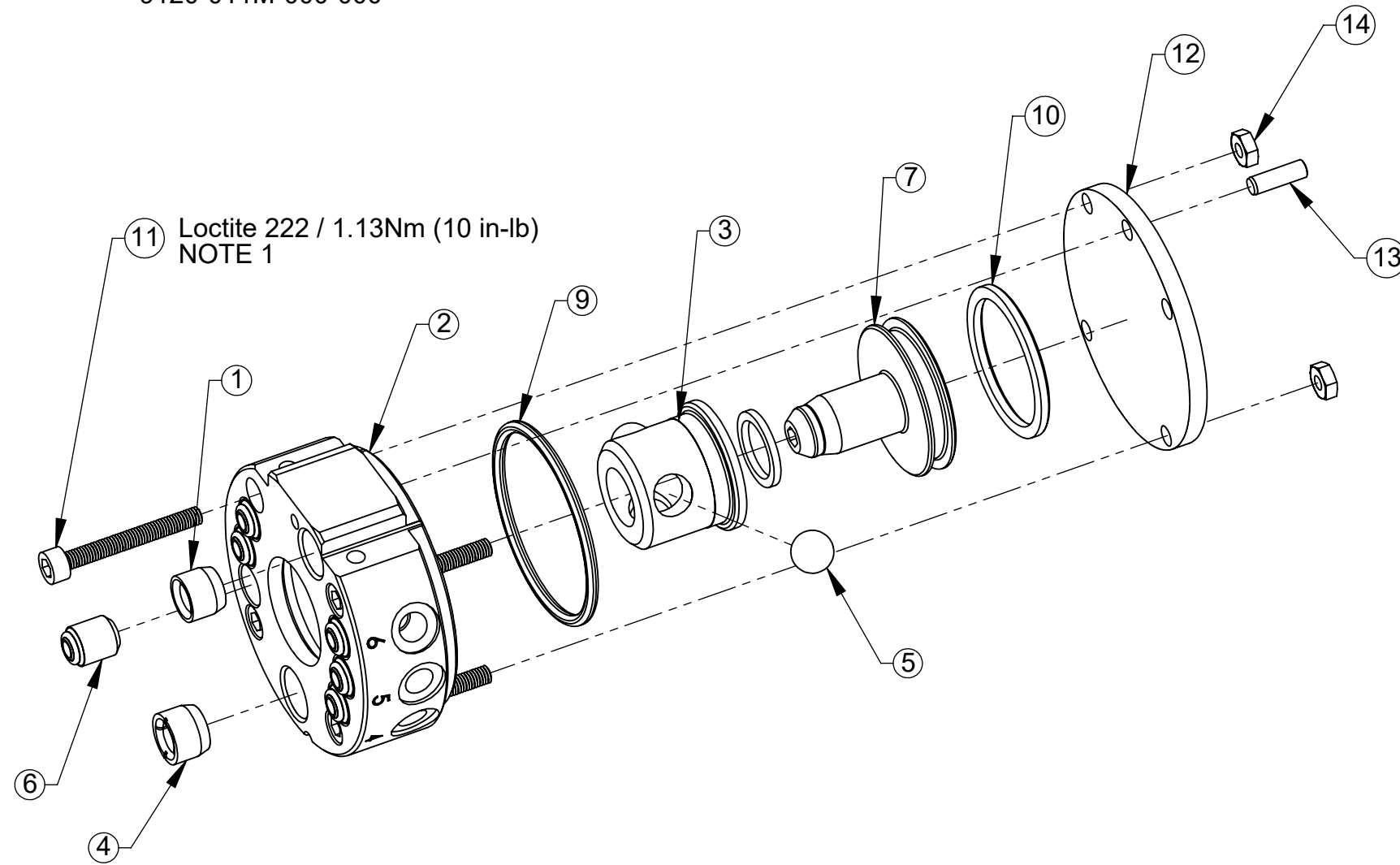

⑪ Loctite 222 / 1.13Nm (10 in-lb)
NOTE 1

NOTES:
1. ASSEMBLE WITH FASTENERS AS LABELED

NOTES: UNLESS OTHERWISE SPECIFIED.

DO NOT SCALE DRAWING.
ALL DIMENSIONS ARE IN MILLIMETERS.

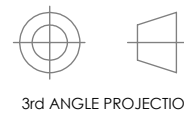

1031 Goodworth Drive, Apex, NC 27539, USA
Tel: +1.919.772.0115 www.ati-ia.com
Fax: +1.919.772.8259 ISO 9001 Registered Company

PROPERTY OF ATI INDUSTRIAL AUTOMATION, INC. NOT TO BE REPRODUCED IN ANY MANNER EXCEPT ON ORDER OR WITH PRIOR WRITTEN AUTHORIZATION OF ATI.

DRAWN BY: D. WAGNER 6/9/20

CHECKED BY: T. CARROLL 7/15/20

TITLE

QC-11 TOOL CHANGER DRAWING

PROJECT #

SHEET 2 OF 3

SCALE
1:1

SIZE
B

DRAWING NUMBER
9630-20-011

REVISION
02

QC-11 TOOL ASSEMBLY

9120-011T-000-000

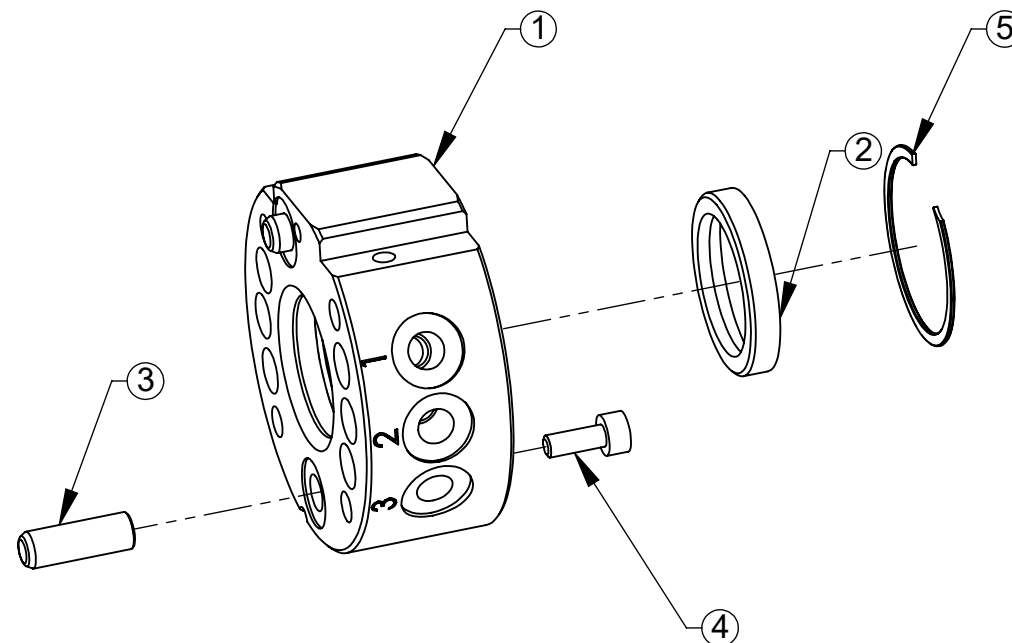

NOTES: UNLESS OTHERWISE SPECIFIED.

DO NOT SCALE DRAWING. ALL DIMENSIONS ARE IN MILLIMETERS.



3rd ANGLE PROJECTION



1031 Goodworth Drive, Apex, NC 27539, USA
 Tel: +1.919.772.0115 www.ati-ia.com
 Fax: +1.919.772.8259 ISO 9001 Registered Company

PROPERTY OF ATI INDUSTRIAL AUTOMATION, INC. NOT TO BE REPRODUCED IN ANY MANNER EXCEPT ON ORDER OR WITH PRIOR WRITTEN AUTHORIZATION OF ATI.

DRAWN BY: D. WAGNER 6/9/20

CHECKED BY: T. CARROLL 7/15/20

TITLE

QC-11 TOOL CHANGER DRAWING

PROJECT # SHEET 3 OF 3

SCALE	SIZE	DRAWING NUMBER	REVISION
1:1	B	9630-20-011	02