

Rev.	Description	Initiator	Date
05	Eco 17075; Added Dowel Pin, added "2X" to dims "2.9" and "1.8" on the coupled view. Changed title from QC-001 to QC-1.	LJH	8/3/2018

Part Numbers:
 (A) Master: 9120-001M-E04-E04
 (B) Tool: 9120-001T-E04-E04

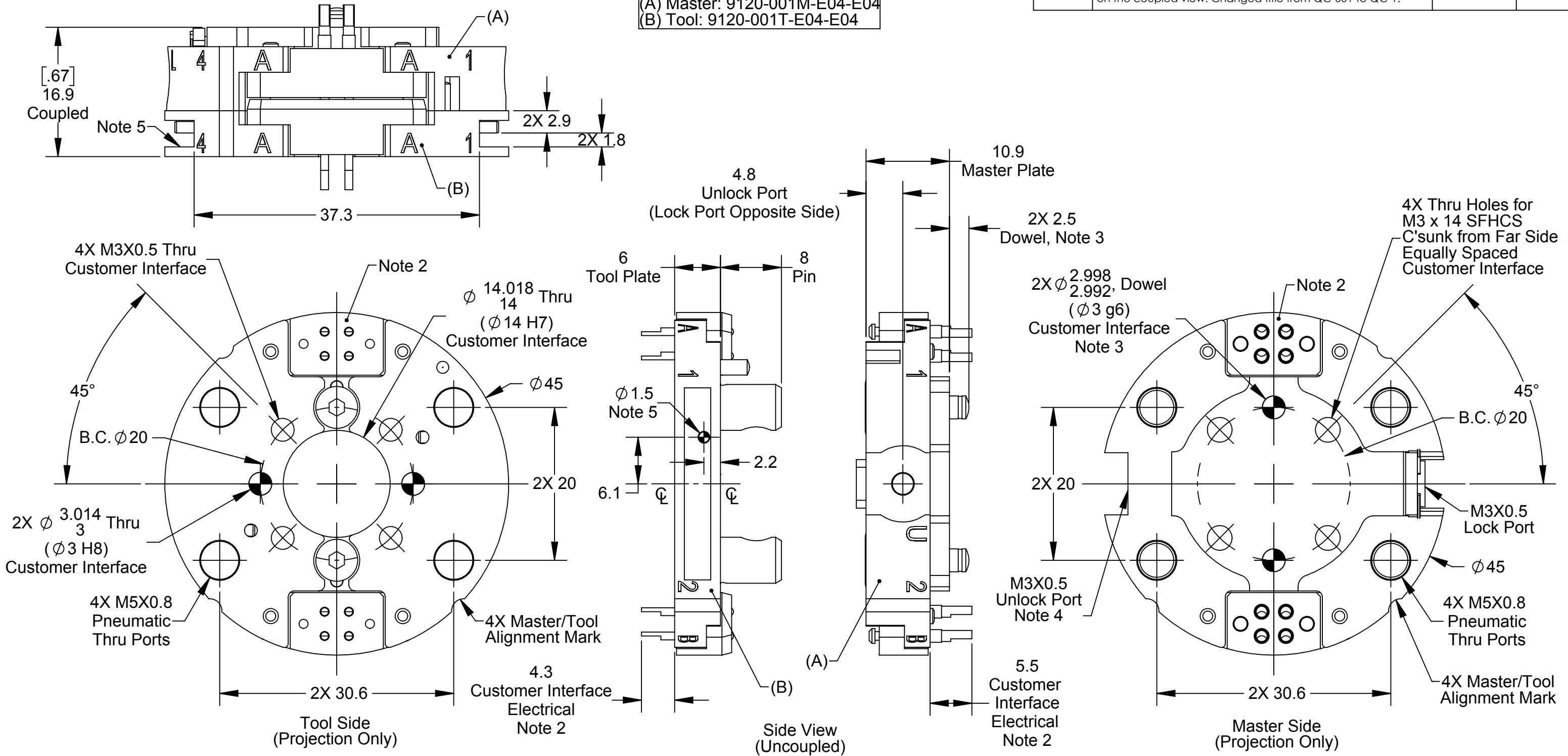

- Notes:
- QC is designed for extremely light payloads.
 - Optional E04 Electrical Modules shown. Total 8 pins @ 3 Amp / 50 VAC. Electrical connections not shown for clarity. Wires attached will require additional clearance.
 - Master Plate includes 2X ϕ 3mm dowel pins. The dowel pins are integral to the mechanical function of the Master Plate and should not be tampered with or damage will occur.
 - Master Plate can be manually set in the Unlock state. Remove fitting and using a ϕ 2mm rod, push the internal Locking Mechanism until Unlock state is achieved.
 - Dowels and grooves serve as an interface for an optional Tool Stand.

NOTES: UNLESS OTHERWISE SPECIFIED.
 DO NOT SCALE DRAWING. ALL DIMENSIONS ARE IN MILLIMETERS.



1031 Goodworth Drive, Apex, NC 27539, USA
 Tel: +1.919.772.0115 Email: info@ati-ia.com
 Fax: +1.919.772.8259 www.ati-ia.com
 ISO 9001 Registered Company

PROPERTY OF ATI INDUSTRIAL AUTOMATION, INC. NOT TO BE REPRODUCED IN ANY MANNER EXCEPT ON ORDER OR WITH PRIOR WRITTEN AUTHORIZATION OF ATI.

DRAWN BY: M. Gala, 11/30/2012		TITLE	
CHECKED BY: D.Norton, 11/30/2012		QC-1 Tool Changer with E04 Modules	
PROJECT # 110614-2	SHEET 1 OF 3	SCALE 2:1	REVISION 05
		SIZE B	DRAWING NUMBER 9630-20-001

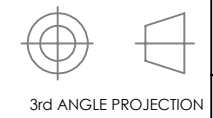

QC-1 Master Assembly

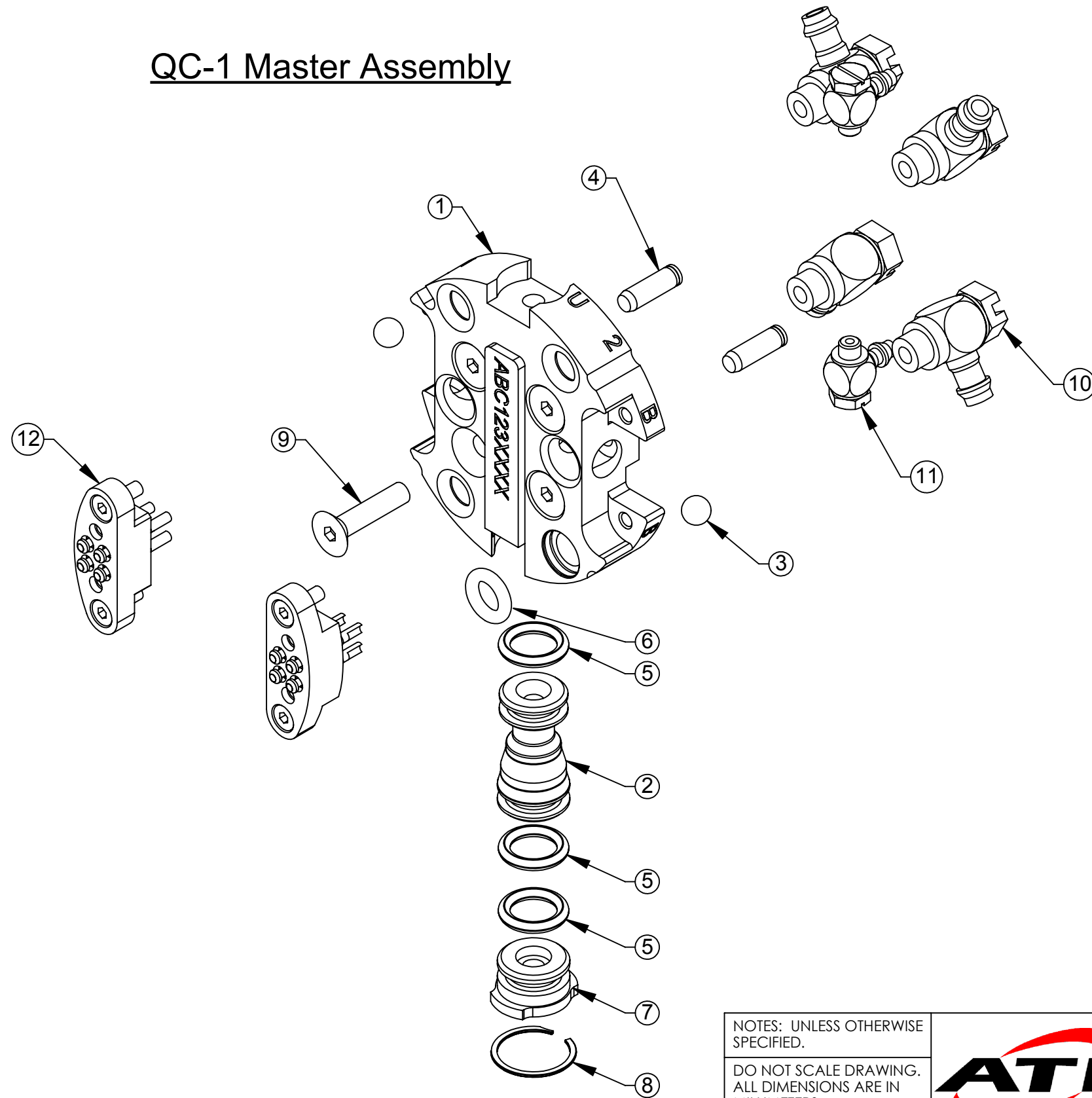

NOTES: UNLESS OTHERWISE SPECIFIED.

DO NOT SCALE DRAWING. ALL DIMENSIONS ARE IN MILLIMETERS.



3rd ANGLE PROJECTION



1031 Goodworth Drive, Apex, NC 27539, USA
 Tel: +1.919.772.0115 Email: info@ati-ia.com
 Fax: +1.919.772.8259 www.ati-ia.com
 ISO 9001 Registered Company

PROPERTY OF ATI INDUSTRIAL AUTOMATION, INC. NOT TO BE REPRODUCED IN ANY MANNER EXCEPT ON ORDER OR WITH PRIOR WRITTEN AUTHORIZATION OF ATI.

DRAWN BY: M. Gala, 11/30/2012		TITLE		
CHECKED BY: D.Norton, 11/30/2012		QC-1 Tool Changer with E04 Modules		
PROJECT #	110614-2	SHEET	OF 3	REVISION
SCALE	1.5:1	SIZE	B	DRAWING NUMBER
				9630-20-001
				05

QC-1 Tool Assembly

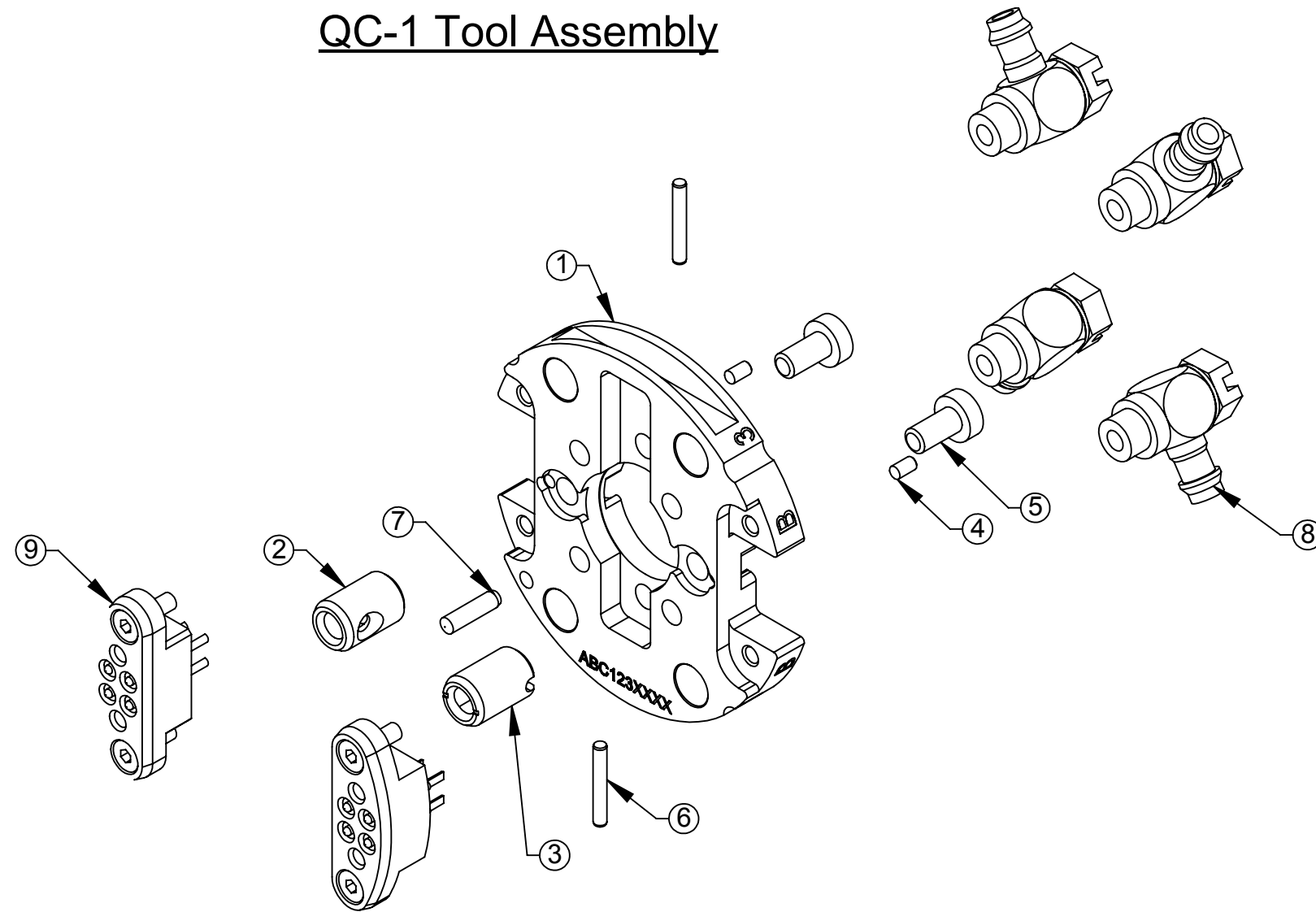

NOTES: UNLESS OTHERWISE SPECIFIED.

DO NOT SCALE DRAWING. ALL DIMENSIONS ARE IN MILLIMETERS.



3rd ANGLE PROJECTION



1031 Goodworth Drive, Apex, NC 27539, USA
 Tel: +1.919.772.0115 Email: info@ati-ia.com
 Fax: +1.919.772.8259 www.ati-ia.com
 ISO 9001 Registered Company

PROPERTY OF ATI INDUSTRIAL AUTOMATION, INC. NOT TO BE REPRODUCED IN ANY MANNER EXCEPT ON ORDER OR WITH PRIOR WRITTEN AUTHORIZATION OF ATI.

DRAWN BY: M. Gala, 11/30/2012		TITLE		
CHECKED BY: D.Norton, 11/30/2012		QC-1 Tool Changer with E04 Modules		
PROJECT #	110614-2	SHEET	3	OF 3
SCALE	1.5:1	SIZE	B	DRAWING NUMBER
				9630-20-001
				REVISION
				05