

Table of Contents

F. High Current Modules	F-2
PA21—High Current Module	F-2
1. Product Overview	F-2
1.1 Optional Fitting Plate Assemblies	F-4
2. Installation	F-5
2.1 Cable Preparation and Installation	F-6
2.2 Module Installation	F-9
2.3 Module Removal	F-9
3. Operation	F-10
4. Maintenance	F-11
5. Troubleshooting and Service Procedures	F-12
5.1 Troubleshooting	F-12
5.1.1 Troubleshooting Sequence.....	F-12
5.2 Service Procedures	F-13
5.2.1 Master Module Contact Tip Replacement	F-13
5.2.2 Tool Module Contact Tip and Wave Spring Replacement	F-14
5.2.3 Module Contact Base Replacement.....	F-15
5.2.4 PA21A-M RobiFix Adapter Assembly Replacement	F-17
5.2.5 PA21APX.XX-T RobiFix Pigtail Assembly Replacement.....	F-18
5.2.6 Tubular Seal Replacement.....	F-19
6. Serviceable Parts and Special Tools	F-20
7. Specifications	F-20
8. Drawings	F-22

F. High Current Modules

PA21—High Current Module

1. Product Overview

The PA21 module carries high current from a power supply to customer tooling. The module features (3) plated copper contacts each capable of carrying 200 Amps; the voltage must not exceed 600 Volts. Power must be off when coupling and uncoupling. Over-current protection in the primary power supply circuit is recommended.



DANGER: This module has a voltage of 50 V or greater; always remove power before contacting the module. Arcing and damage occur if power is not removed from the module during maintenance or service. Always remove power before attaching or disconnecting cables, separating or inserting the mating couplers, or making any contact with the Tool Changer or Utility Coupler.

The PA21 modules use advanced, patented, cone-mating technology to transfer current from the Master to the Tool. The mating conical surfaces provide misalignment capability and a large contact area, allowing efficient coupling/uncoupling without high spring forces or excessive wear. If required, the contact tips on either the Master or Tool can be replaced without removing the wiring. The contact tips on the Master side contain a central insulated post and are recessed below the surface. The Master module's contact pins are designed such that the average adult finger cannot reach the metallic parts.

The modules can accept cabling from either side by changing the position of the end cover plate. An "L" or "R" in the part number designates the direction of cable feed. An "A" in the part number designates the module is outfitted with a RobiFix connector (see table below and [Section 8—Drawings](#)). The standard or plain model requires a fitting plate with strain reliefs to attach customer cabling; some models utilize fixed connectors. For fitting plate assembly options, refer to [Section 1.1—Optional Fitting Plate Assemblies](#). ATI requires the use of high-flex, finely-stranded cables and proper strain relief to allow for motion. The high current tool module provides axially compliant motion in the power contacts. Refer to [Section 2.1—Cable Preparation and Installation](#) for instructions.

Table 1.1—High Current Modules

Module	Description/Connection
9121-PA21L-M	Plain ^{1,2} PA21-M, no connector, Left Feed
9121-PA21R-M	Plain ^{1,2} PA21-M, no connector, Right Feed
9121-PA21L-T	Plain ^{1,2} PA21-T, no connector, Left Feed
9121-PA21R-T	Plain ^{1,2} PA21-T, no connector, Right Feed
9121-PA21LA-M	PA21-M, Robifix connector ³ , Left Feed
9121-PA21RA-M	PA21-M, Robifix connector ³ , Right Feed
9121-PA21LAPX.XX-T	PA21-T, X.XX ⁴ m Robifix Pigtail ³ , Left Feed
9121-PA21RAPX.XX-T	PA21-T, X.XX ⁴ m Robifix Pigtail ³ , Right Feed

Notes:

1. Plain PA21 modules require a fitting plate with cord grips. For fitting plate assembly options, refer to [Section 1.1—Optional Fitting Plate Assemblies](#).
2. Plain PA21 modules are rated for up to 200 Amps continuous.
3. PA21 modules with Robifix connectors or cable mounted Robifix connectors are limited to 150 Amps continuous due to the connector rating.
4. X.XX: length of module cable in meters

Figure 1.1 —PA21 Modules

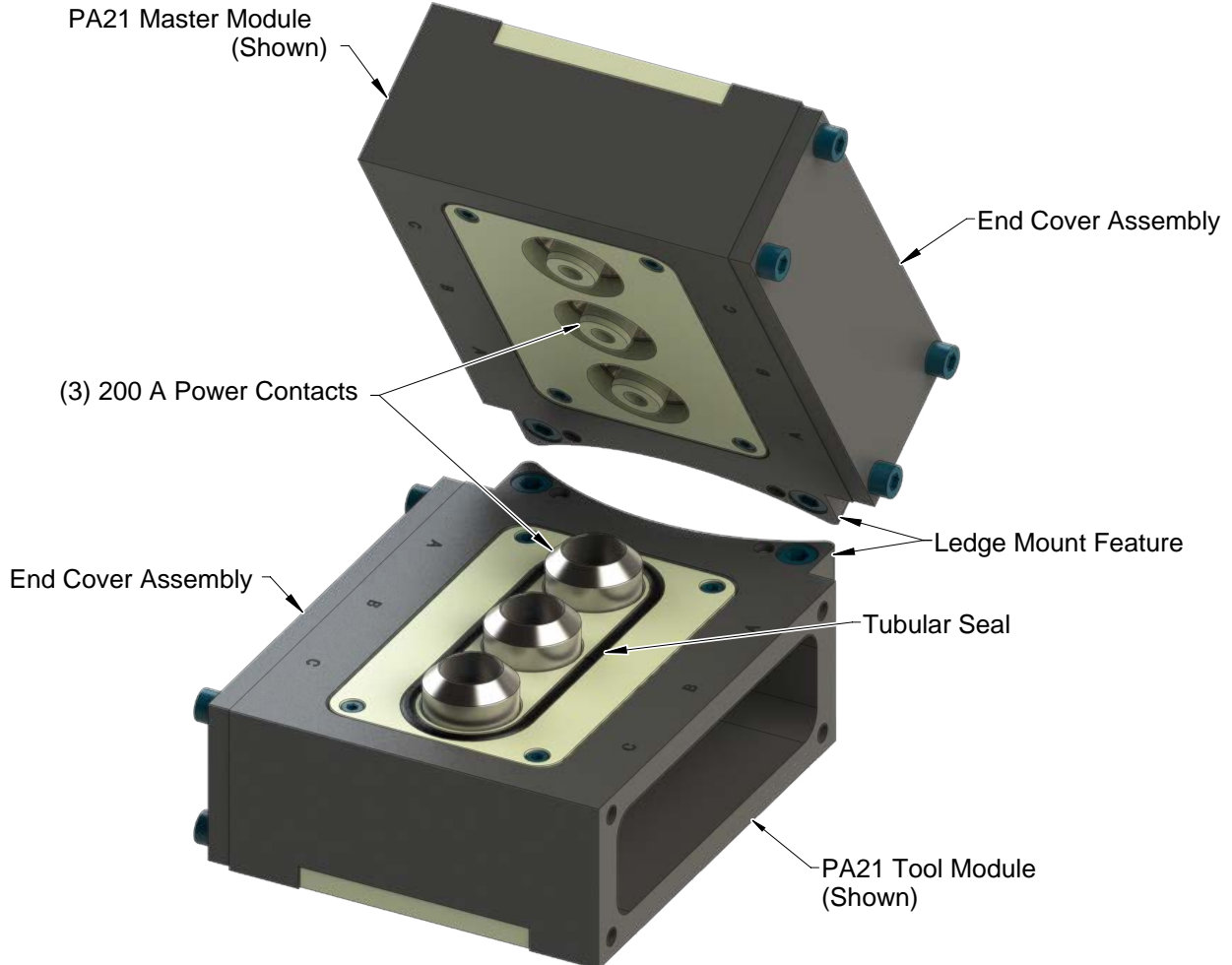



When no module is used on the Tool side, a PAE-T cover may be supplied (per customer request) to protect the Master side power module from dust, debris, and weld spatter.

Figure 1.2—Protective Cover for Tool-side (PAE-T)



1.1 Optional Fitting Plate Assemblies

A fitting plate can integrate cord grips for customer-supplied cables. ATI supplies fitting plate assembly options in the following table. To know which fitting plate is best suited for an application, contact an ATI representative.

Table 1.2—Fitting Plate Assembly		
Part Number		Description
	9005-20-2500	(1) Fitting plate assembly (material: aluminum) (3) M25x1.5 Cord grip, 9-16 mm cable diameter (material: nickel plated brass) (4) M5x40 socket head cap screws, 12.9, ISO4762/DIN912, ES-ATI-007
	9005-20-8887	(1) Fitting plate assembly (material: black Delrin) (3) M25x1.5 cord grips, 5-17 mm cable diameter (material: nylon) (4) M5 x 45 socket head cap screws, 18-8 stainless steel, DIN912-A2

2. Installation

On the standard model, a fitting plate is installed on the modules, the prepared cable ends are fed through the fitting plate into the modules, and the conductors are attached to the contact bases. For ease of cable installation, remove the modules from the Tool Changer. Ring terminals are supplied for use with #2 AWG and #4 AWG cables.

The following steps outline installation or removal of the module and also detail connecting cables to the contacts.



DANGER: This module has a voltage of 50 V or greater; always remove power before contacting the module. Arcing and damage occur if power is not removed from the module during maintenance or service. Always remove power before attaching or disconnecting cables, separating or inserting the mating couplers, or making any contact with the Tool Changer or Utility Coupler.



WARNING: Do not perform maintenance or repair(s) on the Tool Changer or modules unless the tool is safely supported or placed in the tool stand, all energized circuits (e.g. electrical, air, water, etc.) are turned off, pressurized connections are purged and power is discharged from circuits in accordance with the customer's safety practices and policies. Injury or equipment damage can occur with the tool not placed in the tool stand and energized circuits on. Place the tool in the tool stand, turn off and discharge all energized circuits, purge all pressurized connections, and verify all circuits are de-energized before performing maintenance or repair(s) on the Tool Changer or modules.



CAUTION: Do not use stiff, heavy stranded cables that can inhibit operation of the high current module. Stiff cables can prevent compliant motion of the contacts and cause an intermittent or improper power connection. Operation of the high current module requires the customer supplied cables to be high-flex type with fine stranding and sufficient strain relief to allow free cable motion.



CAUTION: Do not use fasteners with pre-applied adhesive more than once. Fasteners might become loose and cause equipment damage. Always apply new thread locker when reusing fasteners.

2.1 Cable Preparation and Installation

Tools required: 2.5 mm and 5 mm hex key, 13 mm socket wrench, 30 mm crows foot wrench, torque wrench, wire stripper, heat gun, manual/hydraulic crimping tool (See [Section 6—Serviceable Parts and Special Tools](#) for recommendations)

Supplies required: heat shrink, Loctite® 222 and 242

1. Prepare the module for cable installation:
 - a. If the module is already installed on the Tool Changer, remove the (2) M6 socket head cap screws that secure the module to the Tool Changer using a 5 mm hex key. Lift the module assembly off the Tool Changer body.
 - b. Using a 2.5 mm hex key, remove the (4) M4 socket flat head cap screws that secure the cover plate assembly to the housing and remove the cover plate.
 - c. Using a 13 mm socket wrench, remove the (3) M8 hex-head cap screws and (3) M8 external tooth washers that secure the ring terminals to the (3) contact bases.
 - d. Remove the (6) ring terminals, which will be used to attach the customer-supplied, high-flex type cables. Note: (3) ring terminals are provided for 25 mm² cable and (3) for 35 mm² cable. Use the size which best fits the cable.

Figure 2.1—Remove the Ring Terminals from the PA21 Module

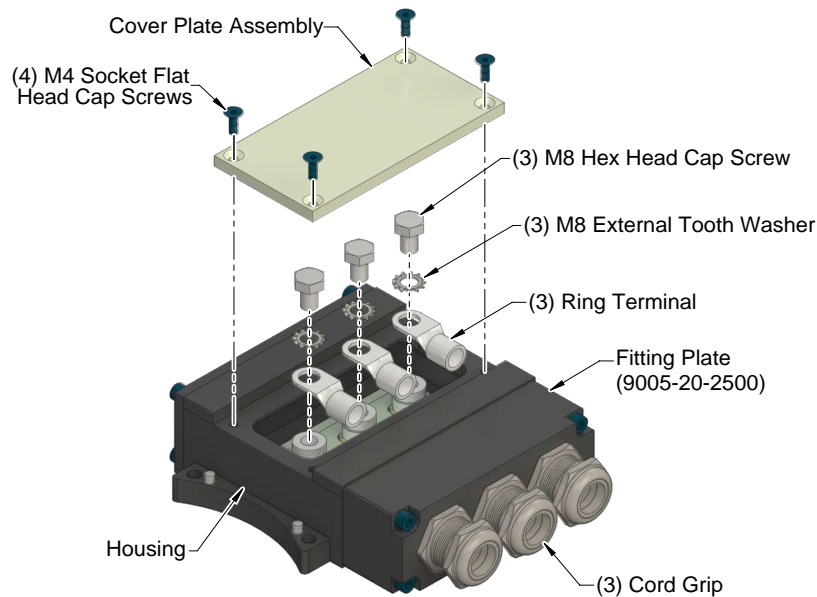

2. Prepare the cables for installation:
 - a. Select the proper size ring terminals (supplied by ATI) for the customer supplied cable.
Note: Where multiple ring terminal sizes are supplied, select the one which best fits the cable.
 - b. Refer to the customer-supplied crimping tool manufacturer's instructions and select the proper size hex dies for the ring terminal and cable.
 - c. Refer to manufacturer instructions for the wire on specific wire preparation and crimping details.
 - d. Prepare the high-flex type cable ends by stripping the insulation back to the approximate length of the crimp of the ring terminal, about 0.5" (12.7 mm). Avoid cutting wire strands while stripping the cable insulation.

Figure 2.2—Wire Stripping

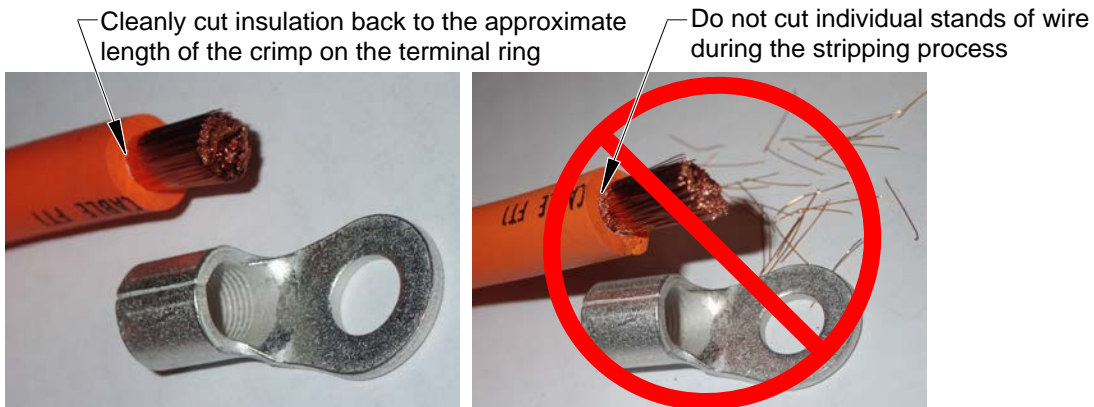

- e. Cut a piece of heat shrink long enough to cover the crimp on the ring terminal and a portion of the cable insulation.
- f. Slide the piece of heat shrink onto the cable; position the heat shrink behind the stripped end of the cable.
- g. Slide the ring terminal over the stripped end of the cable. Ensure there are no wire strands protruding from the ring terminal.
- h. Following manufacturer instructions for the customer-supplied crimp tool, crimp the ring terminal onto the cable.
- i. If the ring terminal tongue distorts during crimping, flatten and straighten the tongue such that its flat portion is parallel to the cable's center axis.
- j. Slide the piece of heat shrink tubing over the ring terminal barrel making sure it completely covers the ring terminal barrel and crimp. Shrink in place using a heat gun.

Figure 2.3 —Connecting the Ring Terminal

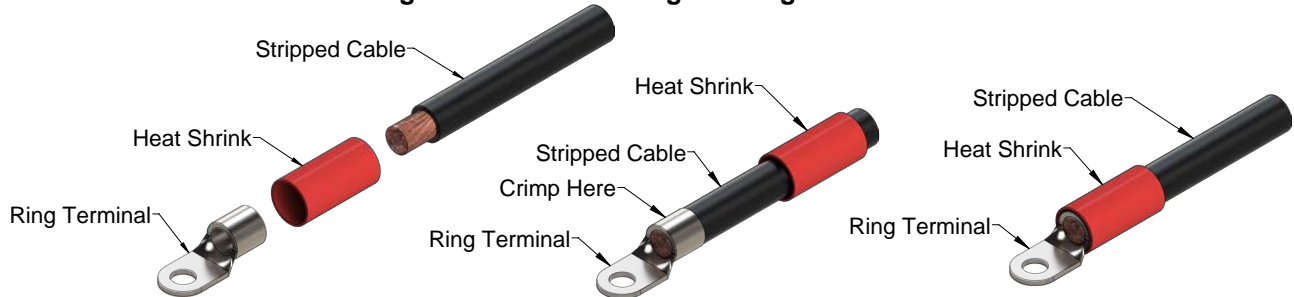

3. Install the cables in the module:
 - a. Using a 30 mm crows foot wrench, loosen the cord grips and route the cable through the fitting plate and cord grips.
 - b. Install and secure the (3) ring terminals to the contact bases using the (3) M8 external tooth washers and (3) M8 hex head cap screws. Tighten finger tight.
 - c. Using a 13 mm socket wrench tighten the (3) M8 hex head cap screws to 90 in-lbs (10 Nm).
 - d. Beginning with the middle cord grip, tighten the cord grip dome nuts to 60 in-lb (6.8 Nm) using the 30 mm crows foot wrench (depending on specific customer cable, the torque value may need to be increased to prevent cable movement).
 - e. Apply Loctite 222 to the (4) M4 socket flat head cap screws and use the screws to install the cover plate assembly to the housing.
 - f. Using a 2.5 mm hex key, tighten the (4) M4 socket flat head cap screws of the cover plate assembly to 12 in-lb (1.4 Nm).
4. Install the module onto the Tool Changer. Refer to [Section 2.2—Module Installation](#).

Figure 2.4—Installing the Cables to the Contact Bases

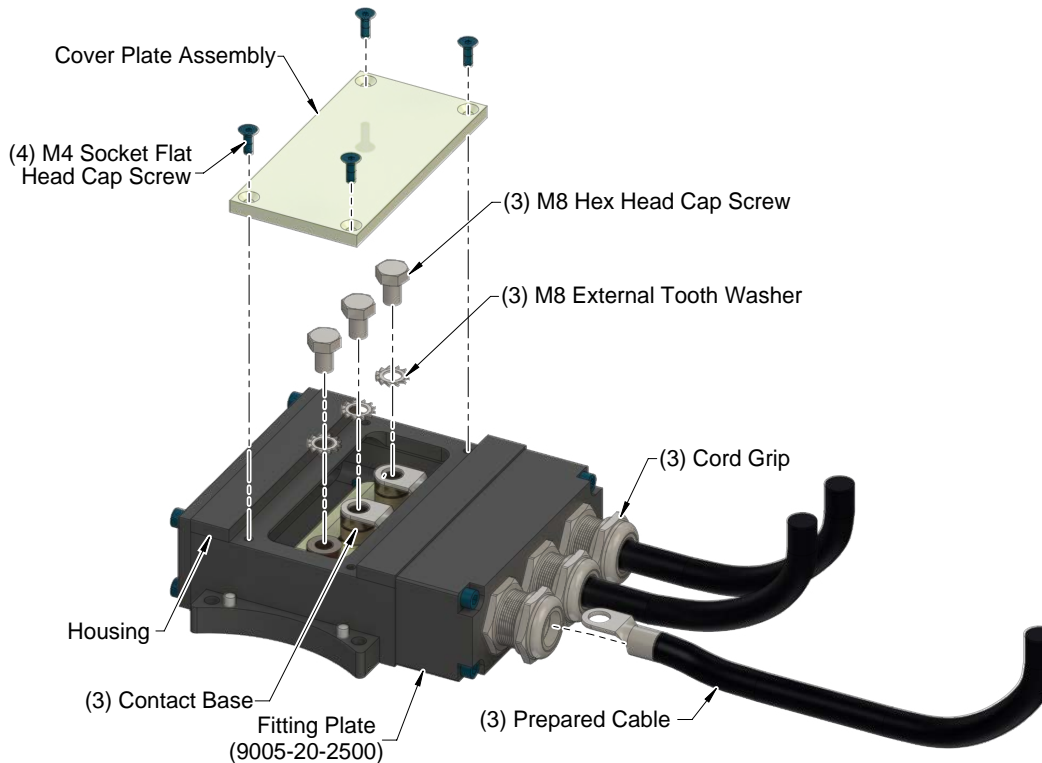

2.2 Module Installation

Tools required: 5 mm hex key

Supplies required: Clean, lint-free rag, Loctite® 242

1. Clean the mating surfaces with a clean, lint-free rag.
2. Place the module on the Tool Changer body. Align the module with the Tool Changer using the dowels in the bottom of the ledge feature.
3. If fasteners do not have pre-applied adhesive, apply Loctite 242 to the supplied (2) M6 socket head cap screws.
4. Install the (2) M6 socket head cap screws securing the module to the Tool Changer using a 5 mm hex key. Tighten to 70 in-lbs (7.9 Nm).
5. Power connections can be connected to the module after attaching the module to the Tool Changer body. Ensure that the connectors are cleaned prior to being secured.
6. After the procedure is complete, resume normal operation.

Figure 2.5—Module Installation

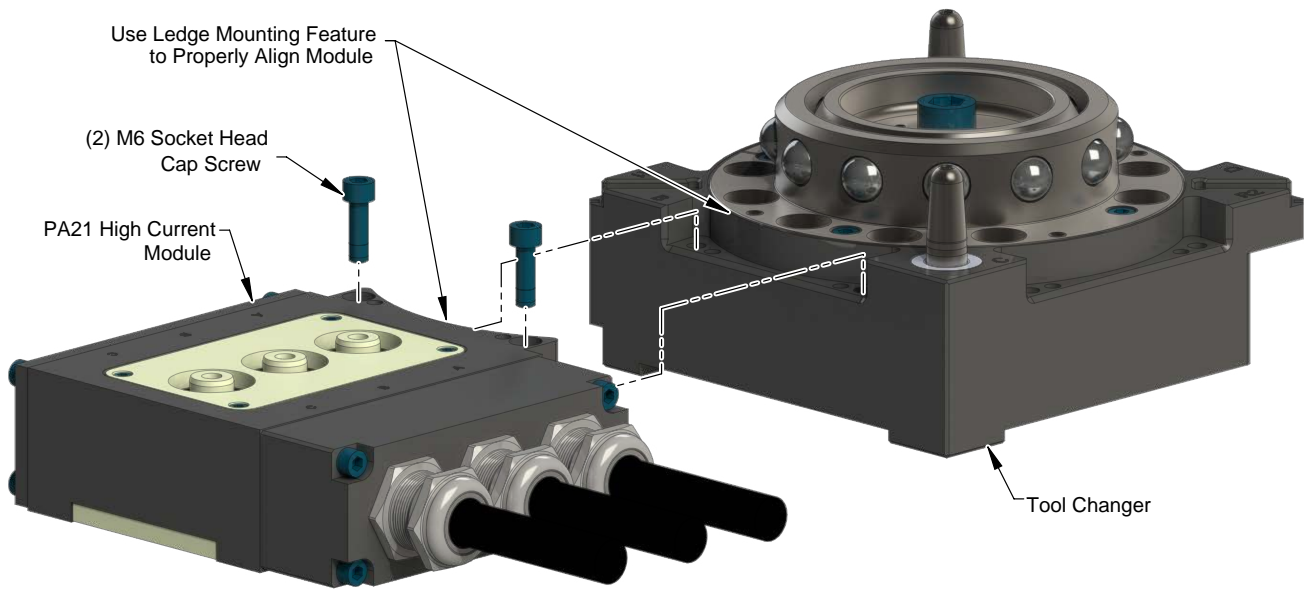

2.3 Module Removal

Tools required: 5 mm hex key

Supplies required: marker pen

1. Place the Tool in a secure location.
2. Uncouple the Master and Tool plates.
3. Turn off and de-energize all energized circuits (e.g. electrical, air, water, etc.).
4. Use a marker pen to indicate where the module is to be re-installed.
5. Disconnect all utility connections.
6. Remove the (2) M6 socket head cap screws using a 5 mm hex key and lift the module from the Tool Changer.

3. Operation

The high current modules are designed to carry large currents to various industrial devices, providing a separable joint in the power wiring. To maximize the service life of these components the following points must be observed:



WARNING: The contacts are not a switch. For safety and to prevent equipment damage, disconnect and drain all power before coupling or uncoupling the Tool Changer or Utility Coupler.



CAUTION: Do not couple or uncouple the high-current modules unless electrical power has been disconnected and discharged both upstream and downstream from the modules. Arcing and contact damage will occur. Remove power and discharge both upstream and downstream modules before coupling or uncoupling modules.



CAUTION: Improper cable routing can result in wires and cables being pinched in the joint between the Tool Changer plates and premature failure of the electrical connectors. Properly route and secure all cables, particularly on the Master side.



CAUTION: Always protect the un-used Tool modules when not coupled to a Master module. Dust, debris, and weld spatter can contaminate the contact tips. Contamination can cause arcing and a significant decrease in contact life.



CAUTION: Do not use stiff, heavy stranded cables that can inhibit operation of the high current module. Stiff cables can prevent compliant motion of the contacts and cause an intermittent or improper power connection. Operation of the high current module requires the customer supplied cables to be high-flex type with fine stranding and sufficient strain relief to allow free cable motion.

4. Maintenance

The condition of the contacts should be checked periodically. Use a stiff nylon brush to remove contamination from the contacts. During inspection, ensure that the fasteners that attach the modules to the Tool Changer are secure.



DANGER: This module has a voltage of 50 V or greater; always remove power before contacting the module. Arcing and damage occur if power is not removed from the module during maintenance or service. Always remove power before attaching or disconnecting cables, separating or inserting the mating couplers, or making any contact with the Tool Changer or Utility Coupler.



WARNING: Do not perform maintenance or repair(s) on the Tool Changer or modules unless the Tool is safely supported or placed in the tool stand, all energized circuits (e.g. electrical, air, water, etc.) are turned off, pressurized connections are purged and power is discharged from circuits in accordance with the customer's safety practices and policies. Injury or equipment damage can occur with the Tool not placed and energized circuits on. Place the Tool in the tool stand, turn off and discharge all energized circuits, purge all pressurized connections, and verify all circuits are de-energized before performing maintenance or repair(s) on the Tool Changer or modules.

5. Troubleshooting and Service Procedures

The following section provides troubleshooting and service information to help diagnose conditions and repair the high current module.



DANGER: This module has a voltage of 50 V or greater; always remove power before contacting the module. Arcing and damage occur if power is not removed from the module during maintenance or service. Always remove power before attaching or disconnecting cables, separating or inserting the mating couplers, or making any contact with the Tool Changer or Utility Coupler.



WARNING: Do not perform maintenance or repair(s) on the Tool Changer or modules unless the Tool is safely supported or placed in the tool stand, all energized circuits (e.g. electrical, air, water, etc.) are turned off, pressurized connections are purged and power is discharged from circuits in accordance with the customer's safety practices and policies. Injury or equipment damage can occur with the Tool not placed and energized circuits on. Place the Tool in the tool stand, turn off and discharge all energized circuits, purge all pressurized connections, and verify all circuits are de-energized before performing maintenance or repair(s) on the Tool Changer or modules.

5.1 Troubleshooting

The high current modules provide a separable joint in the cabling between power sources and industrial devices. Failure of the industrial devices to operate for any reason must be diagnosed electrically.

Table 5.1—Troubleshooting

Symptom	Possible Cause	Correction
Power malfunctioning	Object trapped between modules	Remove object, then re-attempt coupling.
	Contact contamination due to environment	Ensure that the spring loaded contacts on the Tool side can move freely and are not bound by debris. Clean the spring pins to restore free operation. Clean Tool side module contacts, refer to Section 5.2.2—Tool Module Contact Tip and Wave Spring Replacement . Inspect seal and replace if damaged; refer to Section 5.2.6—Tubular Seal Replacement .
	Contact pin separation	Any contamination on the contacts should be removed using a stiff, nylon brush.
		Air supplied to Tool Changer insufficient. Improper valve used. Refer to Tool Changer manual for pneumatic requirements.
	Module contact damage due to coupling/uncoupling under load	Revise operating procedures to only couple/uncouple with power disconnected and discharged. Replace module contacts, refer to Section 5.2.2—Tool Module Contact Tip and Wave Spring Replacement for Tool module.
Connector or Cable damage - Pinched, torn, or fatigued cables, contact base, or contact spring is worn or damaged	Inspect cables and contact base for damage, test cables, test contact springs, refer to Section 5.1.1—Troubleshooting Sequence .	

5.1.1 Troubleshooting Sequence

If it is determined the module contact base is damaged, replace the base. Refer to [Section 5.2.3—Module Contact Base Replacement](#). If the Robifix adapter cable is damaged, replace the adapter. Refer to [Section 5.2.4—PA21A-M RobiFix Adapter Assembly Replacement](#). If the cable is damaged, replace the cable. Refer to [Section 5.2.5—PA21APX.XX-T RobiFix Pigtail Assembly Replacement](#).

5.2 Service Procedures

The following service procedures provide instructions for component replacement.



CAUTION: Do not use fasteners with pre-applied adhesive more than once. Fasteners might become loose and cause equipment damage. Always apply new thread locker when reusing fasteners.

5.2.1 Master Module Contact Tip Replacement

Parts required: Refer to *Section 8—Drawings*.

Tools required: 2.5 mm hex key, torque wrench

Supplies required: Non-hardening, conductive silver bearing grease (ATI 0290-70-0000-50-008, McMaster-Carr #1219K57, AI Technology #ELGR8501 or equivalent)

Removal:

1. Place the Tool in a secure location.
2. Uncouple the Master and Tool plates.
3. Turn off and de-energize all energized circuits (e.g. electrical, air, water, etc.).
4. Remove the M3 socket head cap screw from the center of the insulator post using a 2.5 mm hex key.
5. Remove the insulator post and the Master contact tip. Discard the contact tip.

Figure 5.1—Master Module Contact Tip Replacement

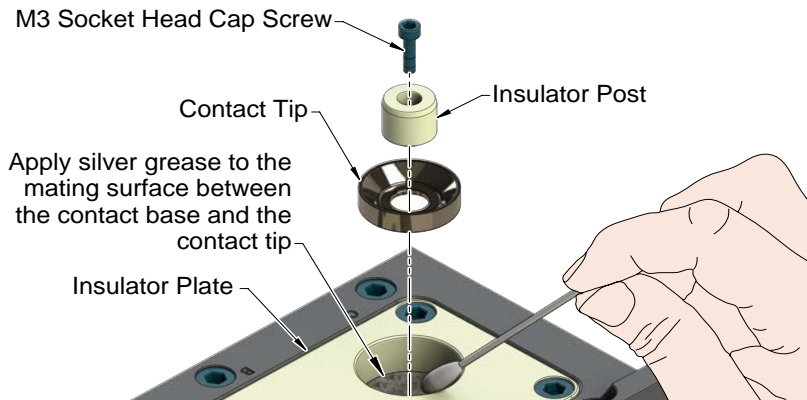

Installation:

NOTICE: Always replace Master and Tool contact tips at the same time (as pairs). Failure to change both halves of a mating pair will result in decreased life of the new component.

6. Apply a thin film of non-hardening, conductive silver bearing grease (ATI 0290-70-0000-50-008, McMaster-Carr #1219K57, AI Technology #ELGR8501 or equivalent) with a volume resistivity of 0.001 ohm-cm minimum to the mating surface between the contact base and the new contact tip. Insert the new contact tip into the insulator plate and reinstall the center insulator post.
7. For an M3 socket head cap screw, insert the screw into the insulator post and secure using a 2.5 mm hex key. Tighten to 10 in-lbs (1.1 Nm).
8. After the procedure is complete, resume normal operation.

5.2.2 Tool Module Contact Tip and Wave Spring Replacement

Parts required: Refer to [Section 8—Drawings](#).

Tools required: 2.5 mm hex key, torque wrench

Supplies required: Non-hardening, conductive silver bearing grease (ATI 0290-70-0000-50-008, McMaster-Carr #1219K57, AI Technology #ELGR8501 or equivalent).

Removal:

1. Place the Tool in a secure location.
2. Uncouple the Master and Tool plates.
3. Turn off and de-energize all energized circuits (e.g. electrical, air, water, etc.).
4. Remove the M3 socket head cap screw from the center of the Tool contact tip using a 2.5 mm hex key.
5. Remove the Tool contact tip and wave spring from the insulator plate and discard.

Figure 5.2—Tool Module Contact Tip and Wave Spring Replacement

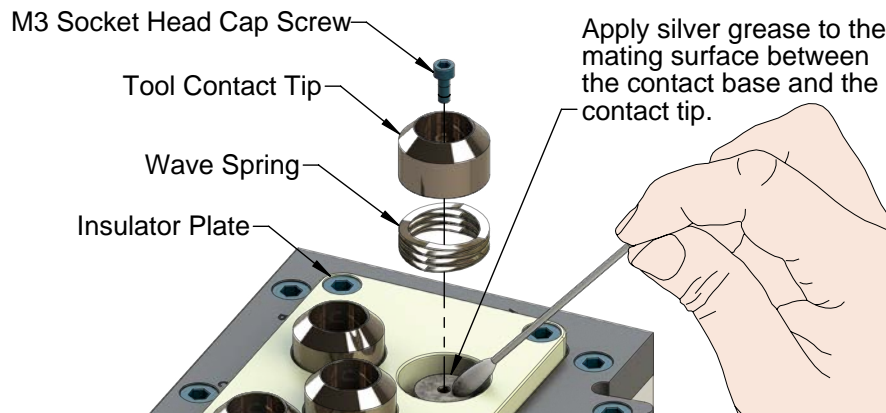

Installation:

NOTICE: ALWAYS replace Master and Tool contact tips at the same time (as pairs). Failure to change both halves of a mating pair will result in decreased life of the new component.

6. Apply a generous amount of non-hardening, conductive silver bearing grease (ATI 0290-70-0000-50-008, McMaster-Carr #1219K57, AI Technology #ELGR8501 or equivalent) with a volume resistivity of 0.001 ohm-cm minimum to the mounting surface between the contact tip and the contact base.
7. Insert the new wave spring and contact tip into the insulator plate.
8. Insert the M3 socket head cap screw into the Tool contact tip and secure using a 2.5 mm hex key. Tighten to 10 in-lbs (1.1 Nm).
9. After the procedure is complete, resume normal operation.

5.2.3 Module Contact Base Replacement

Parts required: Refer to [Section 8—Drawings](#).

Tools required: 2.5 mm and 3 mm hex key, 13 mm socket wrench, torque wrench

Supplies required: Loctite 222

1. Place the Tool in a secure location.
2. Uncouple the Master and Tool plates.
3. Turn off and de-energize all energized circuits (e.g. electrical, air, water, etc.).
4. Remove module from the Tool Changer. Refer to [Section 2.3—Module Removal](#).
5. Remove the contact tip from the contact base to be replaced. Refer to [Section 5.2.1—Master Module Contact Tip Replacement](#) or [Section 5.2.2—Tool Module Contact Tip and Wave Spring Replacement](#).
6. For models with a Robifix adapter, remove the (4) M5 socket flat head cap screws that secure the adapter to the housing using a 3 mm hex key.
7. Using a 2.5 mm hex key, remove the (4) M4 socket flat head screws that secure the cover plate assembly to the housing and remove the cover plate assembly.
8. Using a 13 mm socket wrench, remove the (3) M8 hex head cap screws and (3) M8 external tooth washers securing the ring terminals to each contact base.

9. Using a 2.5 mm hex key, remove the (4) M3 socket head cap screws that secure the contact block to the module housing. Remove the contact block. (Note: the contact block may also be referred to as an insulator plate).
10. Remove the C-clip from the contact base being replaced.
11. Remove the contact base by sliding it out of the contact block.

Figure 5.3—Remove Old Contact Base

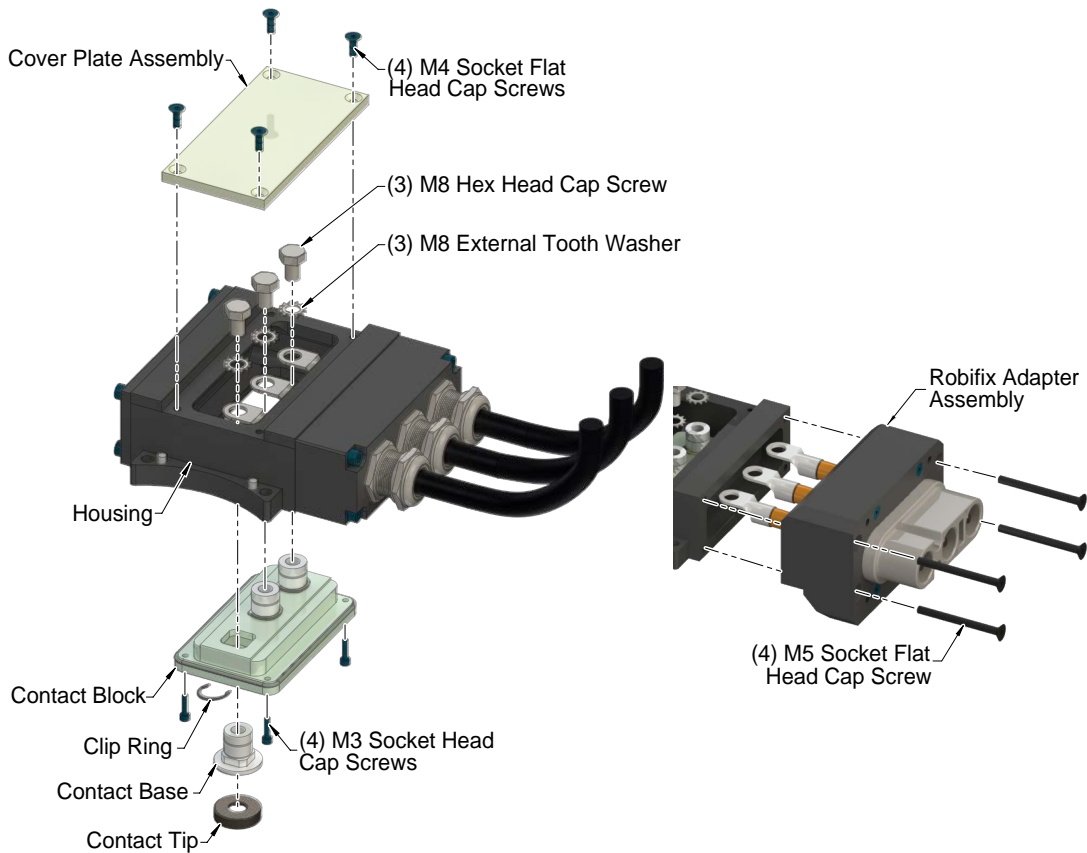

12. Install the new contact base into the contact block in the correct orientation.
13. Install the C-clip onto the new contact base.
14. Install the contact block in the housing using the (4) M3 socket head cap screws and a 2.5 mm hex key. Tighten the screws to 10 in-lb (1.1 Nm).
15. Attach the ring terminals to the contact bases and secure with (3) M8 external tooth washers and (3) M8 hex head cap screws. Using a 13 mm socket wrench, tighten the screws to 90 in-lbs (10 Nm).
16. Apply Loctite 222 to the cover plate assembly's (4) M4 socket flat head cap screws. Use a 2.5 mm hex key to install and secure the cover plate assembly to the housing; tighten the screws to 12 in-lb (1.4 Nm).
17. For models with a Robifix adapter, apply Loctite 222 to the adapter's (4) M5 socket flat head cap screws. Use a 3 mm hex key to install and secure the adapter to the housing (refer to [Figure 5.3](#)) and tighten the screws to 25 in-lb (2.8 Nm).
18. Install the contact tip to the contact base to be replaced. Refer to [Section 5.2.1—Master Module Contact Tip Replacement](#) and [Section 5.2.2—Tool Module Contact Tip and Wave Spring Replacement](#).
19. Install the module onto the Tool Changer. Refer to [Section 2.2—Module Installation](#).
20. When the above procedure is complete, resume normal operation.

5.2.4 PA21A-M RobiFix Adapter Assembly Replacement

Parts required: Refer to [Section 8—Drawings](#).

Tools required: 2.5 mm and 3 mm hex key, 13 mm socket wrench, torque wrench

Supplies required: Loctite 222

1. Place the Tool in a secure location.
2. Uncouple the Master and Tool plates.
3. Turn off and de-energize all energized circuits (e.g. electrical, air, water, etc.).
4. Remove module from the Tool Changer. Refer to [Section 2.3—Module Removal](#).
5. Using a 3 mm hex key, remove the (4) M5 socket flat head cap screws that secure the RobiFix adapter assembly to the housing.
6. Using a 2.5 mm hex key, remove the (4) M4 socket flat head cap screws that secure the cover plate assembly to the housing and remove the cover plate assembly.
7. Using a 13 mm socket wrench, remove the (3) M8 hex head cap screws and (3) M8 external tooth washers that secure the ring terminals to the contact bases. Remove the old RobiFix adapter assembly.

Figure 5.4—Replacing the PA21A-M RobiFix Adapter Assembly

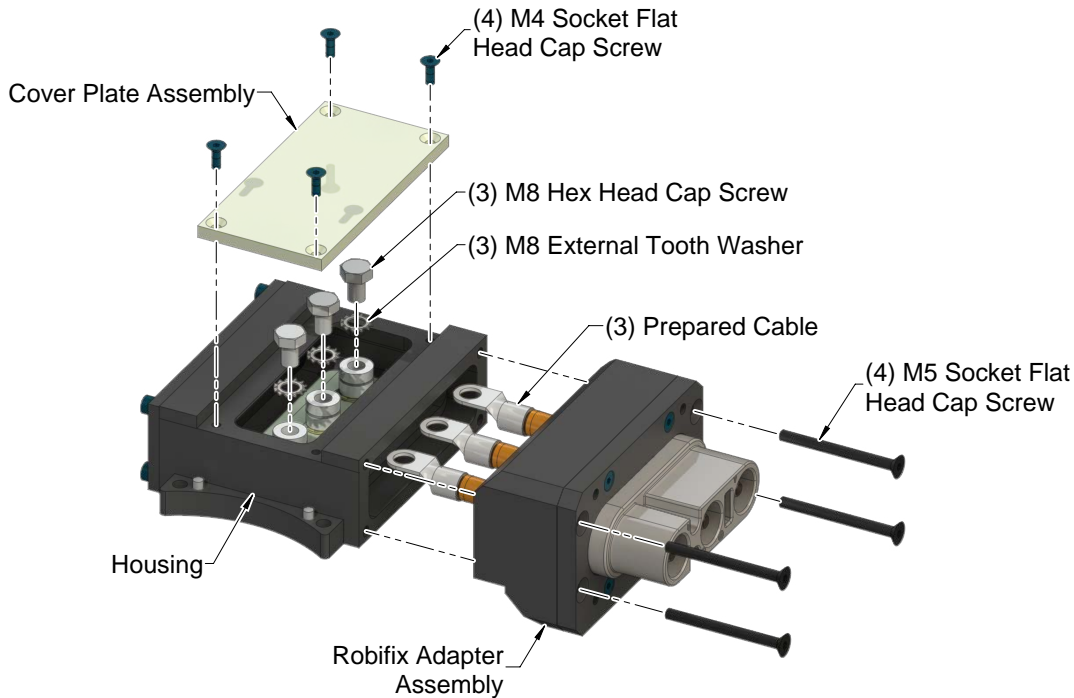

8. Apply Loctite 222 to the adapter's (4) M5 socket flat head cap screws. Use a 3 mm hex key to install and secure the adapter to the housing; tighten the screws to 25 in-lb (2.8 Nm).
9. Attach the ring terminals to the contact bases and secure with the (3) M8 external tooth washers and (3) M8 hex head cap screws using a 13 mm socket wrench. Tighten to 90 in-lbs (10 Nm).
10. Apply Loctite 222 to the cover plate assembly's (4) M4 socket flat head cap screws. Use a 2.5 mm hex key to install and secure the cover plate assembly to the housing; tighten the screws to 12 in-lb (1.4 Nm).
11. Install the module onto the Tool Changer. Refer to [Section 2.2—Module Installation](#).
12. When the above procedure is complete, resume normal operation.

5.2.5 PA21APX.XX-T RobiFix Pigtail Assembly Replacement

(X.XX: length of PA21AP-T cable in meters)

Parts required: Refer to [Section 8—Drawings](#).

Tools required: 2.5 mm hex key, 13 mm socket wrench, 30 mm crows foot wrench, torque wrench

Supplies required: Loctite 222

1. Place the Tool in a secure location.
2. Uncouple the Master and Tool plates.
3. Turn off and de-energize all energized circuits (e.g. electrical, air, water, etc.).
4. Remove the module from the Tool Changer. Refer to [Section 2.3—Module Removal](#).
5. Using a 2.5 mm hex key, remove the (4) M4 socket flat head cap screws that secure the cover plate assembly to the housing. Remove the cover plate assembly.
6. Using a 13 mm socket wrench, remove the (3) M8 hex head cap screws and (3) M8 external tooth washers that secure the ring terminals to the contact bases. Remove the old RobiFix pigtail assembly.
7. If needed, use a 30 mm crows foot wrench to loosen the cord grips and route the cable through the cord grips and fitting plate.
8. Attach each of the ring terminals to the appropriate contact base and secure with the M8 external tooth washer and M8 hex head cap screw. Tighten to 90 in-lb (10 Nm) using a 13 mm socket wrench.
9. Tighten the cord grip dome nut finger-tight. Starting with the middle fitting, tighten an additional 1-1/2 turns using a 30 mm crows foot wrench.
10. Apply Loctite 222 to the cover plate assembly's (4) M4 socket flat head cap screws. Use a 2.5 mm hex key to install and secure the cover plate assembly to the housing; tighten the screws to 12 in-lb (1.4 Nm).
11. Install the module onto the Tool Changer. Refer to [Section 2.2—Module Installation](#).
12. When the above procedure is complete, resume normal operation.

Figure 5.5—RobiFix Pigtail Assembly Installation

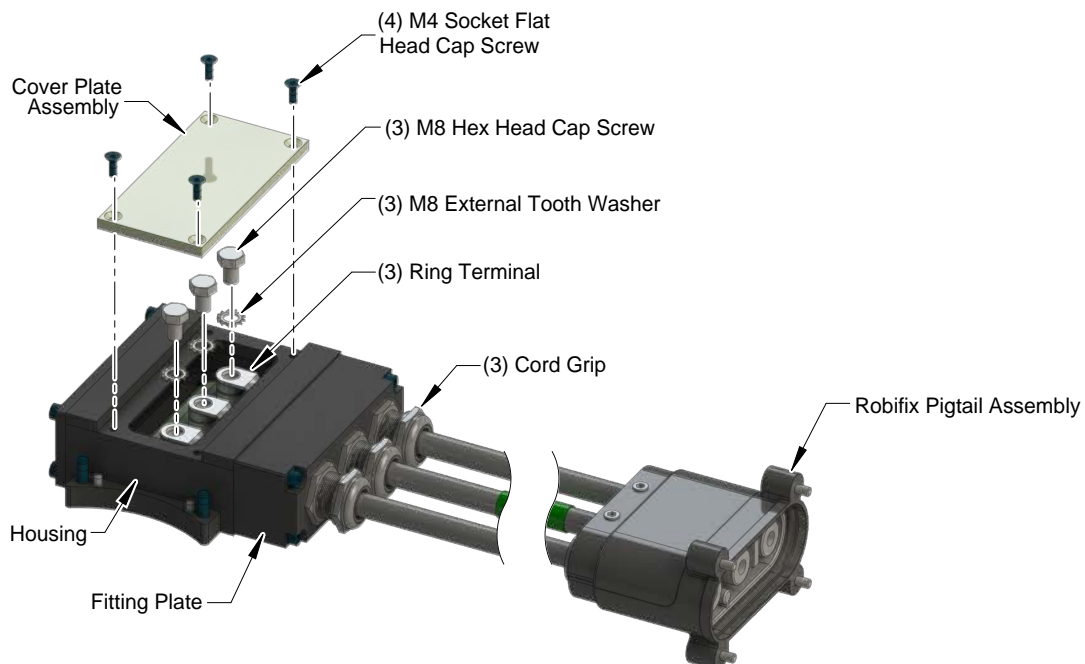

5.2.6 Tubular Seal Replacement

The tubular seal protects the electrical connection between the Master and Tool module. If the seal becomes worn or damaged, it needs to be replaced.

Parts required: Refer to [Section 8—Drawings](#).

1. Place the Tool in a secure location.
2. Uncouple the Master and Tool plates.
3. Turn off and de-energize all energized circuits (e.g. electrical, air, water, etc.).
4. To replace the tubular seal on the Tool module, use a small screwdriver to gently pry the seal out of its retention groove.
5. To install a new seal, place it over the empty groove in the Tool side insulator plate and press the seal in place.
6. After the procedure is complete, resume normal operation.

Figure 5.6—Tubular Seal Replacement

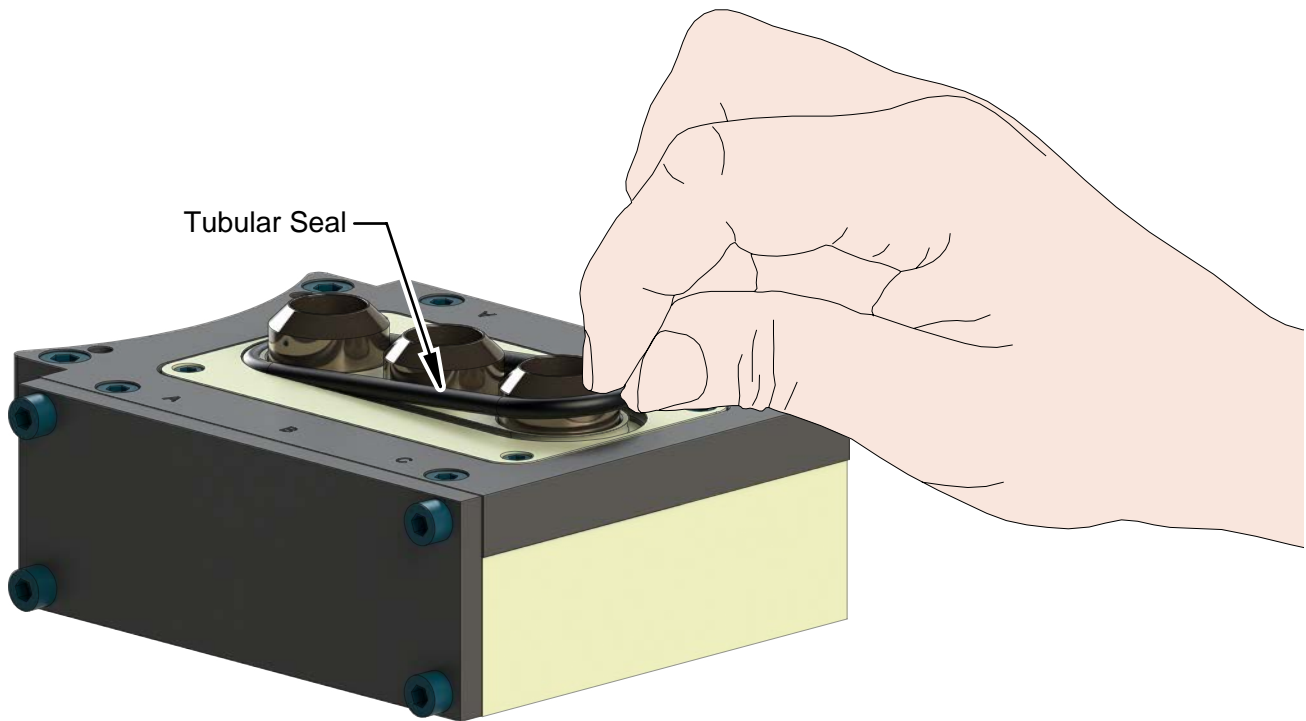

NOTICE: Individual parts may differ slightly in appearance from what is shown in the figure above.

6. Serviceable Parts and Special Tools

Refer to [Section 8—Drawings](#).

Table 6.1—Master Module Mounting Fasteners		
Part Number	QTY	Description
3500-1066020-21A	2	M6 x 20 Socket Head Cap Screw, SS, ND Microspheres.

Table 6.2—Tool Module Mounting Fasteners		
Part Number	QTY	Description
3500-1066016-21A	2	M6 x 16 Socket Head Cap Screw, ND, Microspheres.

Table 6.3—Special Tools	
Part Number	Description
3690-0000064-60	Brush, Blue Nylon All Purpose (Contact Pin Cleaning)
Manual/Hydraulic crimping tool (Not sold by ATI)	Elpress 2600C, Multi-Contact/Staubli 18.3710, or equivalent
Crimping dies (Not sold by ATI)	Elpress TB9-13 (16 & 35 mm ²), TB11-14.5 (25 & 50 mm ²), Multi-Contact/Staubli 18.3712 (16 & 35 mm ²), 18.3713 (25 & 50 mm ²), or equivalent(s). Other crimp tools may also produce satisfactory results.

7. Specifications

Table 7.1—Master Module	
9121-PA21L(R)-M	200 A Compact Power Module, Master
Interface Connections	(3) Power Contacts
Electrical Rating	200 A, 600 V Max.
Cable Sizes Supported	#2 AWG (Ring Terminals) #4 AWG (Ring Terminals) Ring terminals are used to attach the conductor to the contact base.
Weight	2.3 lbs (1.04 kg)

Table 7.2—Master Module	
9121-PA21L(R)A-M	150 A Compact Power Module, Master
Interface Connections	Straight RobiFix Bulkhead Connector
Electrical Rating	150 A, 600 V Max. Current limited by connector.
Cable Sizes Supported	#2 AWG High-flex type with fine stranding (Others, Contact ATI) Ring terminals are used to attach the conductor to the contact base.
Weight	5 lbs (2.27 kg)

Table 7.3—Tool Module	
9121-PA21L(R)-T	200 A Compact Power Module, Tool
Interface Connections	(3) Power Contacts
Electrical Rating	200 A, 600 V Max.
Cable Sizes Supported	#2 AWG (Ring Terminals) High-flex type with fine stranding (Others, Contact ATI) #4 AWG (Ring Terminals) High-flex type with fine stranding (Others, Contact ATI) Ring terminals are used to attach the conductor to the contact base.
Weight	2.4 lbs (1.09 kg)

Table 7.4—Tool Module	
9121-PA21L(R) AP1.00-T	Primary Current Tool Module with 1.0 M Pigtail Robifix Connector, 150 Amps
Interface Connections	1 meter pigtail and RobiFix connector
Electrical Rating	150 A, 600 V Max. Current limited by connector.
Cable Sizes Supported	#2 AWG High-flex type with fine stranding (Others, Contact ATI) Ring terminals are used to attach the conductor to the contact base.
Weight	4.3 lbs (1.96 kg) + 6.5 lbs (2.95 kg) / meter of cable.

Table 7.5—Tool Module	
9121-PA21L(R) AP1.20-T	Primary Current Tool Module with 1.2 M Pigtail Robifix Connector, 150 Amps
Interface Connections	1.2 meter pigtail and RobiFix connector
Electrical Rating	150 A, 600 V Max. Current limited by connector.
Cable Sizes Supported	#2 AWG High-flex type with fine stranding (Others, Contact ATI) Ring terminals are used to attach the conductor to the contact base.
Weight	4.3 lbs (1.96 kg) + 6.5 lbs (2.95 kg) / meter of cable.

Table 7.6—Tool Module	
9121-PA21L(R) AP1.50-T	Primary Current Tool Module with 1.5 M Pigtail Robifix Connector, 150 Amps
Interface Connections	1.5 meter pigtail and RobiFix connector
Electrical Rating	150 A, 600 V Max. Current limited by connector.
Cable Sizes Supported	#2 AWG High-flex type with fine stranding (Others, Contact ATI) Ring terminals are used to attach the conductor to the contact base.
Weight	4.3 lbs (1.96 kg) + 6.5 lbs (2.95 kg) / meter of cable.

Table 7.7—Tool Module	
9121-PA21L(R) AP2.00-T	Primary Current Tool Module with 2.0 M Pigtail Robifix Connector, 150 Amps
Interface Connections	2 meter pigtail and RobiFix connector
Electrical Rating	150 A, 600 V Max. Current limited by connector.
Cable Sizes Supported	#2 AWG High-flex type with fine stranding (Others, Contact ATI) Ring terminals are used to attach the conductor to the contact base.
Weight	4.3 lbs (1.96 kg) + 6.5 lbs (2.95 kg) / meter of cable.

Table 7.8—Tool Side Cover	
9121-PAE-T	Protective cover when tool side module is not installed.
Weight	0.44 lbs (0.2 kg)

8. Drawings

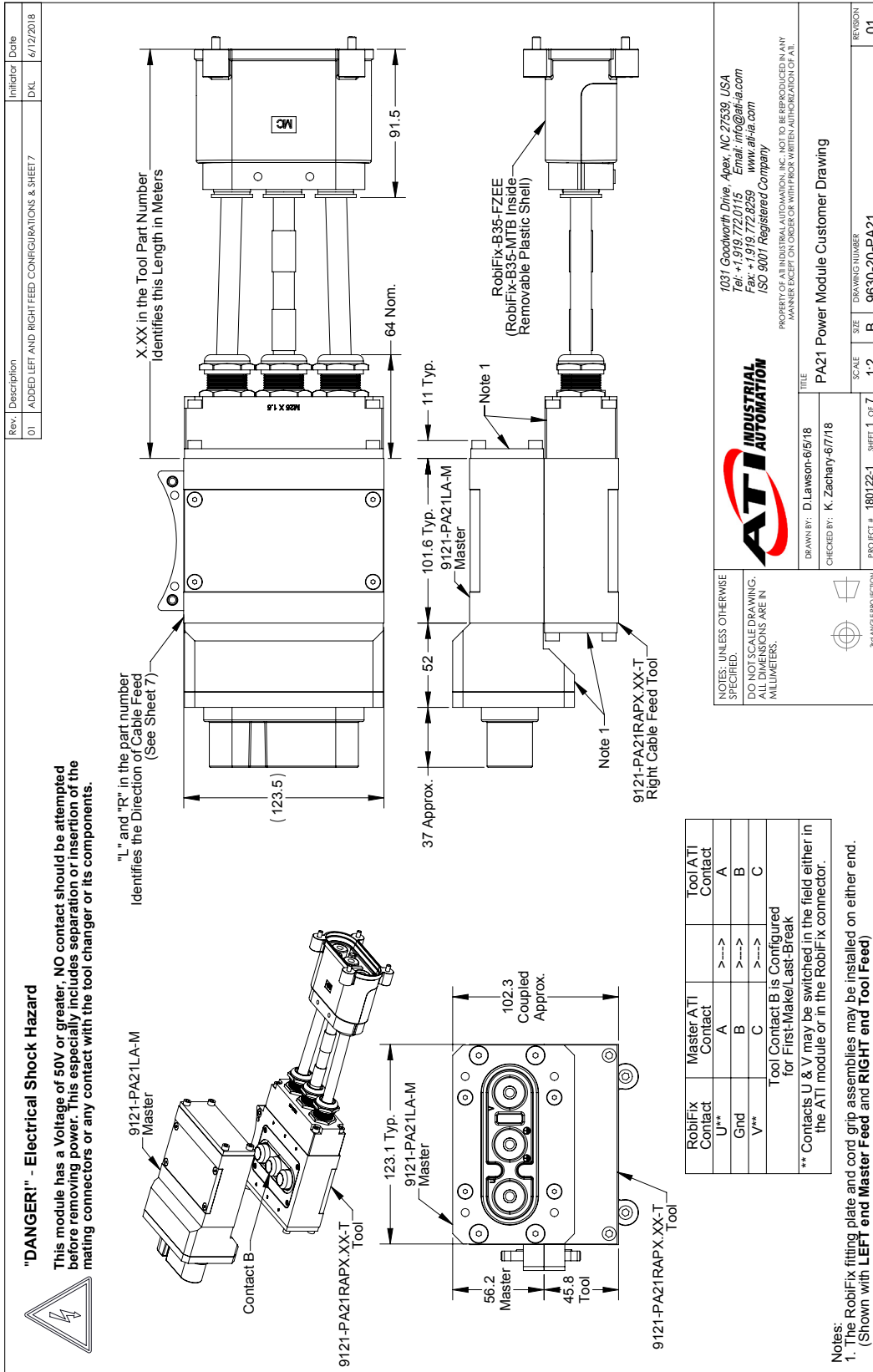

1031 Goodworth Drive, Apex, NC 27539, USA
 Tel: +1 919.772.0115 Email: info@ati-ia.com
 Fax: +1 919.772.8259 www.ati-ia.com
 ISO 9001 Registered Company

PROPERTY OF ATI INDUSTRIAL AUTOMATION, INC. NOT TO BE REPRODUCED IN ANY MANNER EXCEPT ON ORDER OR WITH PRIOR WRITTEN APPROVAL OF ATI.

ATI INDUSTRIAL AUTOMATION

DRAWN BY: D.Lawson-6/5/18
 CHECKED BY: K. Zachary-6/7/18
 PROJECT #: 180122-1 SHEET 1 OF 7
 TITLE: PA21 Power Module Customer Drawing
 SCALE: 1:2
 DRAWING NUMBER: 9630-20-PA21
 REVISION: 01

Master Side Parts 9121-PA21R-M & 9121-PA21L-M

Left Feed Shown. For Right Feed the End Cover Assembly is Located on the Opposite Side

Full Master Rebuild Kit = 9005-20-2580
 Contains 1 each of items: 4, 5, 7, 9, 10, 11 & 13

Tip Master Rebuild Kit = 9005-20-2582
 Contains 1 each of items: 5, 10 & 11

ITEM NO.	QTY	PART NUMBER	DESCRIPTION
1	3	1705-0610219-03	Ring Terminal, Non Insulated, #2 AWG, 3/8" Stud
2	3	1705-0610220-03	Ring Terminal, Non Insulated, #4 AWG, 5/16 Stud
3	1	3410-0001439-01	O-Ring, 85mm x 2mm, Nitrile, 70A
4	3	3500-0868012-12	M8 x 12 HHCS, Zinc, 8.8
5	7	3500-1058012-15A	M3-0.5 x 12mm SHCS, Blue, Pre-Applied
6	2	3500-1066020-15A	M6-1 x 20mm SHCS, Blue, Pre-Applied
7	3	3510-5267001-12	Washer, Lock, Ext. Tooth, M8, Steel, Zn Plt, DIN 6797A
8	2	3540-0105016-11	5mm x 16mm Dowel Alloy Steel
9	3	3690-6500004-11	Low-Clearance C-Style Ring for 5/8" Shaft Dia.
10	3	3700-20-4153	INSULATOR POST, MASTER
11	3	3700-20-8523	Contact Tip, 200A, Master, Silver Plate
12	1	3700-20-9501	Contact Block, PA20, Master
13	3	3700-20-9510	Contact Base, 200A, Bolt Type, PAXX Master
14	1	3700-20-10484	Housing, Box, PA20
15	1	9005-20-2495	End Cover Assembly, PA20, 44.8mm
16	1	9005-20-2603	Cover Plate Assembly, PA21

Screws Supplied with Cover
Loctite 222 / 12 in-lb

90 in-lb
To Next Assembly

4 90 in-lb

10 in-lb

5 10 in-lb

Screws Supplied with Cover
Loctite 222 / 25 in-lb

Magnatube
Note 2

Note 1

Notes:

- Apply silver grease to the bottom surface per the product manual.
- After applying Magnatube to the o-ring, fit to the underside of the contact carrier, then slip the contact carrier and seal into the housing.

NOTES: UNLESS OTHERWISE SPECIFIED:
 DO NOT SCALE DRAWING.
 ALL DIMENSIONS ARE IN INCHES.

3RD ANGLE PROJECTION

ATI INDUSTRIAL AUTOMATION

1031 Goodworth Drive, Apex, NC 27639, USA
 Tel: +1.919.772.0115 Email: info@ati-ia.com
 Fax: +1.919.772.8259 www.ati-ia.com
 ISO 9001 Registered Company

PROPERTY OF ATI INDUSTRIAL AUTOMATION, INC. NOT TO BE REPRODUCED IN ANY MANNER EXCEPT ON ORDER OR WITH PRIOR WRITTEN AUTHORIZATION OF ATI.

DRAWN BY: D.Lawson-6/5/18
 CHECKED BY: K.Zachary-6/7/18
 PROJECT #: 180122-1 SHEET 2 OF 7
 SCALE: 1:2
 DRAWING NUMBER: 9630-20-PA21
 REVISION: 01

TITLE: PA21 Power Module Customer Drawing

Tool Side Parts 9121-PA21R-T & 9121-PA21L-T

Right Feed Shown. For Left Feed the End Cover Assembly is Located on the Opposite Side

Full Tool Rebuild Kit = 9005-20-2581
 Contains 1 each of items: 4, 5, 7, 9, 10, 11 & 13

Tip Tool Rebuild Kit = 9005-20-2583
 Contains 1 each of items: 5, 9 & 11

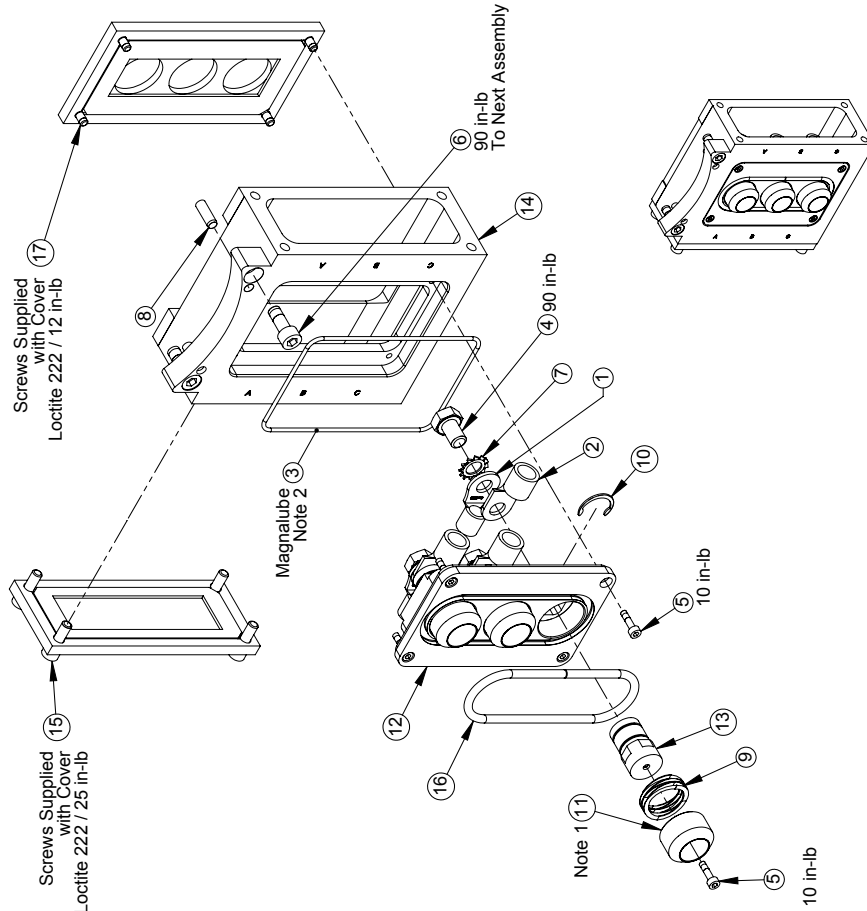

- Notes:
1. Apply silver grease to the bottom surface per the product manual.
 2. After applying Magnalube to the o-ring, fit to the underside of the contact carrier, then slip the contact carrier and seal into the housing.

ITEM NO.	QTY	PART NUMBER	DESCRIPTION
1	3	1705-0610220-03	Ring Terminal, Non Insulated, #4 AWG, 5/16 Stud
2	3	1705-5510202-03	Ring Term., #2x8mm, AMP 322870
3	1	3410-0001439-01	O-Ring, 85mm x 2mm, Nitrile, 70A
4	3	3500-0868012-12	M8 x 12 HHCS, Zinc, 8.8
5	7	3500-1058012-15A	M3-0.5 x 12mm SHCS, Blue, Pre-Applied
6	2	3500-1066016-15A	M6-1 x 16mm SHCS, Blue, Pre-Applied
7	3	3510-5267001-12	Washer, Lock, Ext. Tooth, M8, Steel, Zn Plt, DIN 6797A
8	2	3540-0105016-11	5mm x 16mm Dowel Alloy Steel
9	3	3610-7301101-21	Wave Spring, .91"OD x .44 Lg-Smalley 14892-08
10	3	3690-6500004-11	Low-Clearance C-Style Ring for 5/8" Shaft Dia.
11	3	3700-20-8524	Contact Tip, 200A, Tool, Silver Plate
12	1	3700-20-9511	Contact Carrier Plate, PA20-T
13	3	3700-20-9512	200A Contact Base, Bolt Type, PAXX Tool
14	1	3700-20-10484	Housing, Box, PA20
15	1	9005-20-2495	End Cover Assembly, PA20, 44.8mm
16	1	9005-20-2498	8.3" x 4mm Dia. Viton Tubular Seal, PA20-T
17	1	9005-20-2603	Cover Plate Assembly, PA21

NOTES: UNLESS OTHERWISE SPECIFIED:
 DO NOT SCALE DRAWING.
 ALL DIMENSIONS ARE IN INCHES.



1031 Goodworth Drive, Apex, NC 27539, USA
 Tel: +1.919.772.0115 Email: info@ati-ia.com
 Fax: +1.919.772.8259 www.ati-ia.com
 ISO 9001 Registered Company

PROPERTY OF ATI INDUSTRIAL AUTOMATION, INC. NOT TO BE REPRODUCED IN ANY MANNER EXCEPT ON ORDER OR WITH PRIOR WRITTEN AUTHORIZATION FROM ATI.

DRAWN BY: D.Lawson-6/5/18 CHECKED BY: K.Zachary-6/7/18	TITLE: PA21 Power Module Customer Drawing
PROJECT #: 180122-1 SHEET 3 OF 7	SCALE: 1:2 DRAWING NUMBER: 9630-20-PA21
3RD ANGLE PROJECTION	REVISION: 01

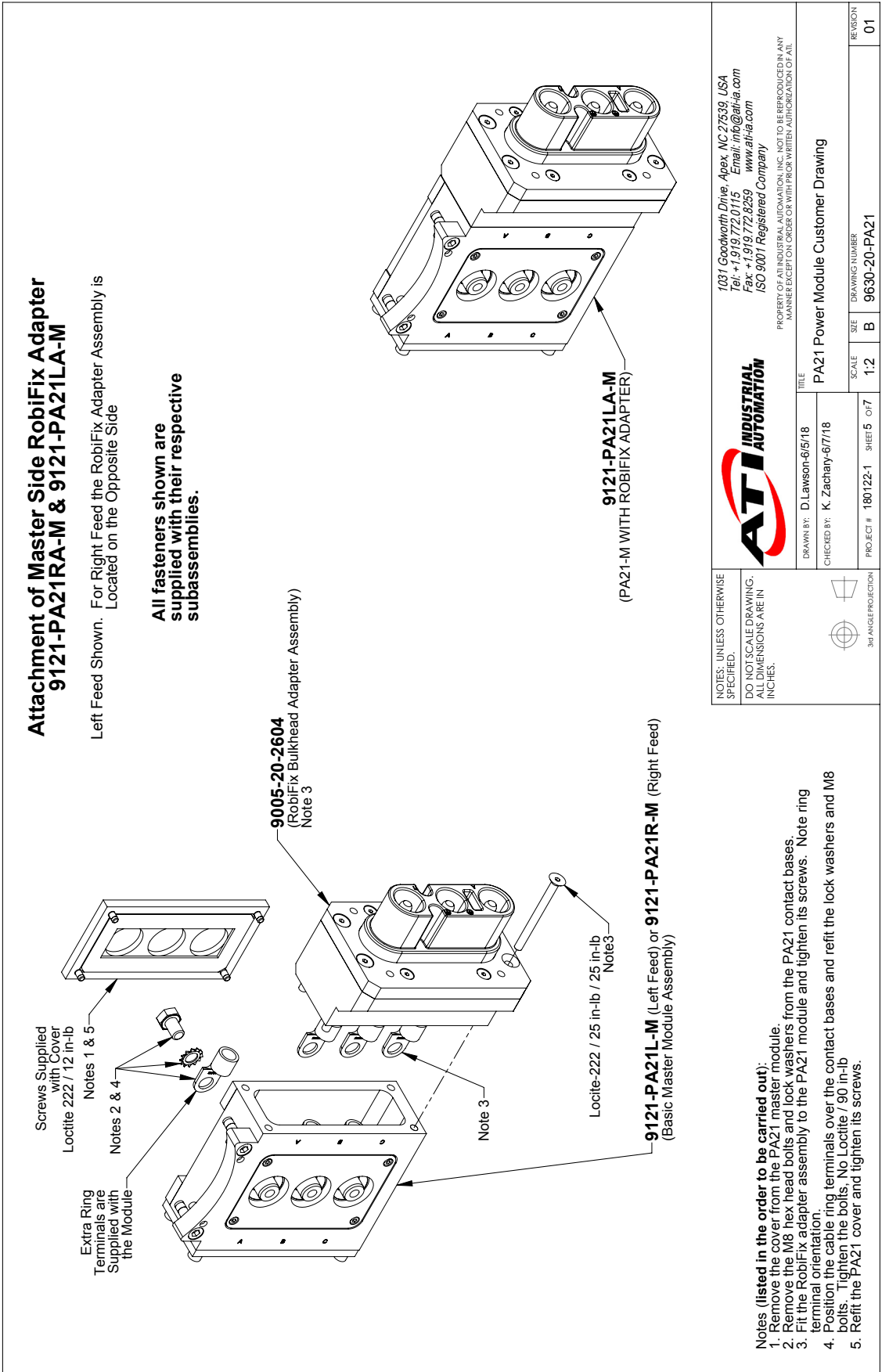

**Attachment of Master Side RobiFix Adapter
 9121-PA21RA-M & 9121-PA21LA-M**

Left Feed Shown. For Right Feed the RobiFix Adapter Assembly is Located on the Opposite Side

All fasteners shown are supplied with their respective subassemblies.

NOTES: UNLESS OTHERWISE SPECIFIED:
 DO NOT SCALE DRAWING. ALL DIMENSIONS ARE IN INCHES.

1031 Goodworth Drive, Apex, NC 27539, USA
 Tel: +1 919 772 0115 Email: info@ati-ia.com
 Fax: +1 919 772 8259 www.ati-ia.com
 ISO 9001 Registered Company

PROPERTY OF AT INDUSTRIAL AUTOMATION, INC. NOT TO BE REPRODUCED IN ANY MANNER EXCEPT BY ORDER OR WITH PROX WRITTEN AUTHORIZATION OF ATIL.

ATI INDUSTRIAL AUTOMATION

DRAWN BY: D.Lawson-6/5/18
 CHECKED BY: K.Zachary-6/7/18

TITLE: PA21 Power Module Customer Drawing

PROJECT # 180122-1 SHEET 5 OF 7

SCALE 1:2
 SIZE B
 DRAWING NUMBER 9630-20-PA21

REVISION 01

3RD ANGLE PROJECTION

- Notes (listed in the order to be carried out):**
1. Remove the cover from the PA21 master module.
 2. Remove the M8 hex head bolts and lock washers from the PA21 contact bases.
 3. Fit the RobiFix adapter assembly to the PA21 module and tighten its screws. Note ring terminal orientation.
 4. Position the cable ring terminals over the contact bases and refit the lock washers and M8 bolts. Tighten the bolts. No Loctite / 90 in-lb.
 5. Refit the PA21 cover and tighten its screws.

Attachment of the Tool Side RobiFix Pigtail Adapter 9121-PA21LAPX.XX-T & 9121-PA21RAPX.XX-T

(X.XX in the Part Number Specifies the Pigtail Length in Meters)
 Right Feed Shown. For Left Feed the RobiFix Adapter Assembly is Located on the Opposite Side

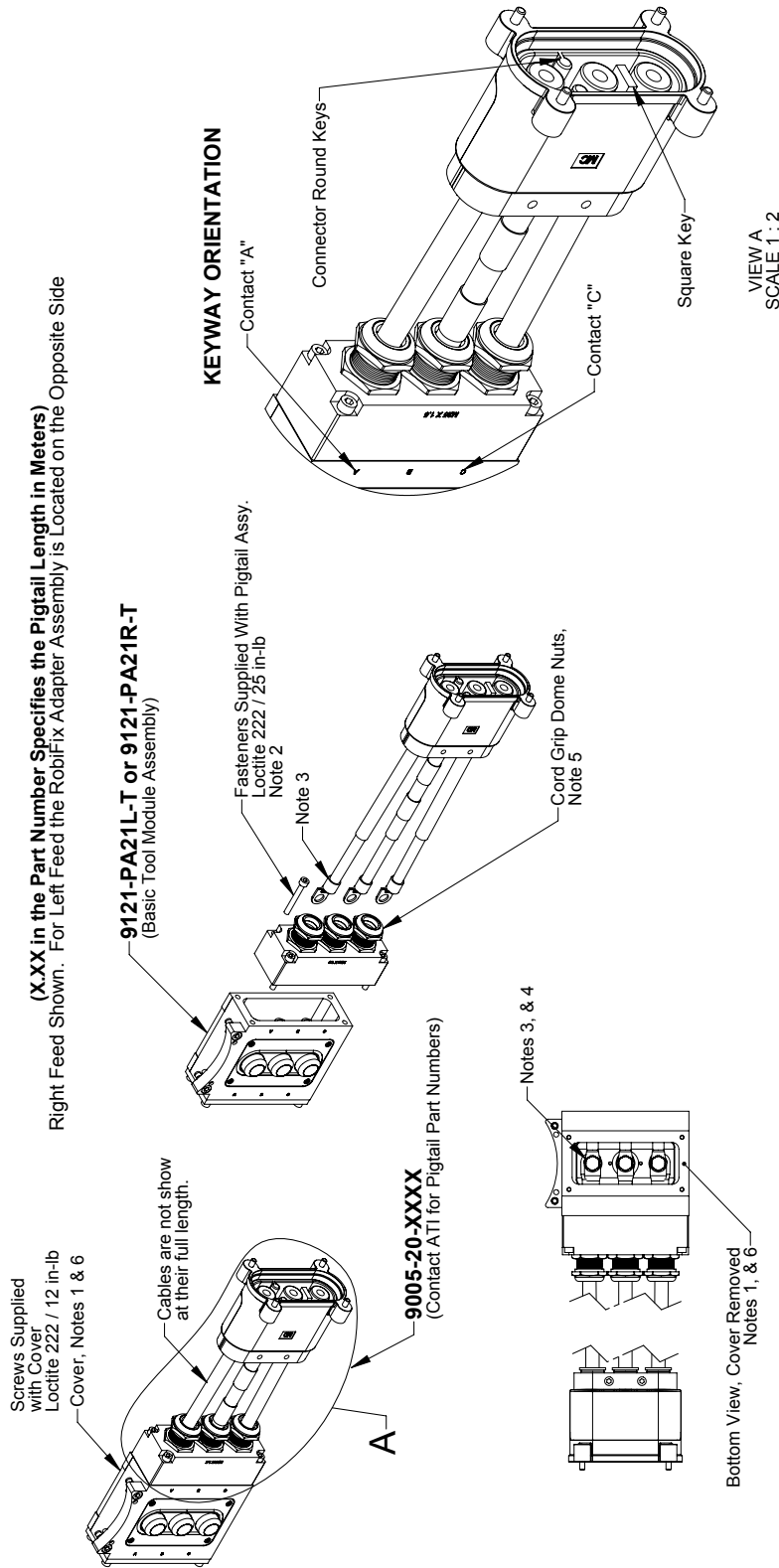

Perform the assembly steps in the order listed below.

1. Remove the cover from the PA21-T module.
2. Attach the fitting plate assembly to the PA21 housing and tighten its mounting screws.
3. Route the cables from the pigtail through the cord grips (observe the cable routing in View A).
4. Insert the hex head bolts through the lock washers and ring terminals and tighten the bolts.
5. Tighten the cord grip dome nuts one at a time starting with the middle fitting.
6. Fit the cover and tighten its mounting screws.

NOTES: UNLESS OTHERWISE SPECIFIED:
 DO NOT SCALE DRAWING.
 ALL DIMENSIONS ARE IN MILLIMETERS.



1031 Goodworth Drive, Apex, NC 27539, USA
 Tel: +1.919.772.0115 Email: info@ati-ia.com
 Fax: +1.919.772.8259 www.ati-ia.com
 ISO 9001 Registered Company

PROPERTY OF ATI INDUSTRIAL AUTOMATION, INC. NOT TO BE REPRODUCED IN ANY MANNER EXCEPT ON ORDER OR WITH PROOK WRITTEN AUTHORIZATION OF ATI.

DRAWN BY: D. Lawson-6/5/18		TITLE: PA21 Power Module Customer Drawing	
CHECKED BY: K. Zachary-6/7/18		SCALE: 1:4	DRAWING NUMBER: B 9630-20-PA21
PROJECT #: 180122-1	SHEET 6 OF 7	REVISION:	01

Determining the Direction of Cable Feed (Left or Right Feed, See Notes)

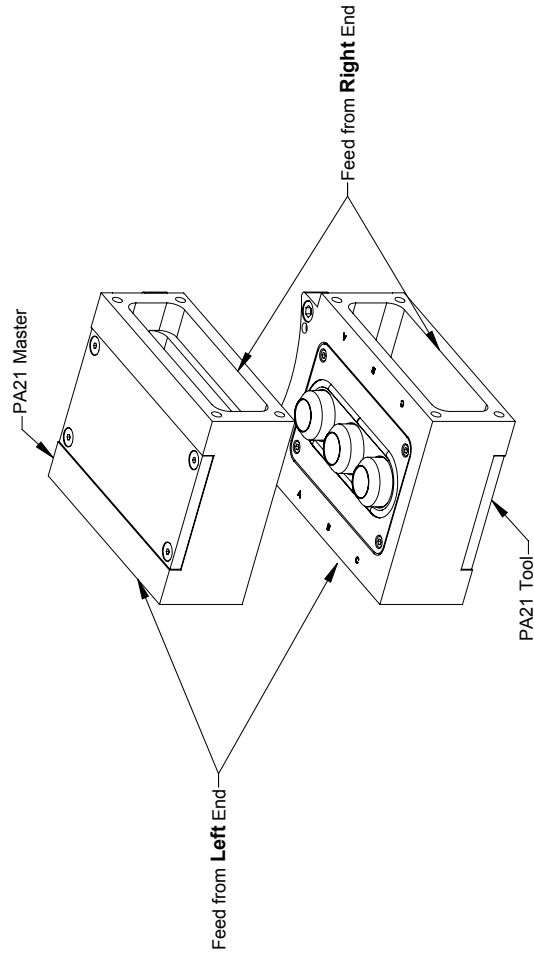

Left and Right are Defined by the Orientation Shown Above with the Master Module on Top and the Tool Module Below.

- Notes:
1. The PA21 can be configured for cable connections on either the left or right end of the module.
 2. "L" or "R" in the part number designates the direction of cable feed as defined in the image above.
 3. If the incorrect feed direction is purchased, the modules can be quickly and easily converted in the field by switching the end cover and cord grip plates.
 4. When the RobiFix adapter is attached to the PA21 Master module, the tool side adapter MUST be on the opposite end of the tool module (i.e. for Master assembly 9121-PA21LA-M (left feed), configure the Tool as 9121-PA21RA-XX-T (right feed)).

NOTES: UNLESS OTHERWISE SPECIFIED, DO NOT SCALE DRAWING. ALL DIMENSIONS ARE IN MILLIMETERS.



1031 Goodworth Drive, Apex, NC 27539, USA
 Tel: +1 919.772.0115 Email: info@ati-ia.com
 Fax: +1 919.772.8259 www.ati-ia.com
 ISO 9001 Registered Company

DRAWN BY: D.Lawson-6/5/18		TITLE: PA21 Power Module Customer Drawing	
CHECKED BY: K.Zachary-6/7/18		SCALE: 1:2	SIZE: B
PROJECT #: 180122-1	SHEET 7 OF 7	DRAWING NUMBER: 9630-20-PA21	REVISION: 01