

Table of Contents

E. Electrical Modules	2
RU10-M/T—Electrical Module.....	2
1. Product Overview	2
2. Installation	3
2.1 Installing	3
2.2 Removal	3
3. Operation	3
4. Maintenance.....	3
5. Troubleshooting	3
6. Recommended Spare Parts	4
7. Specifications	4
8. Drawings	5

E. Electrical Modules

RU10-M/T—Electrical Module

1. Product Overview

The electrical modules are required to provide a means for the customer to communicate through the Tool Changer

Amphenol USBFTV22N style connectors are provided for interfacing on the Master and Tool modules. When the tool changer is coupled, the Master and Tool signal modules communicate with each other using a spring loaded pin block. A flexible boot surrounds the pin block to seal the connection from moisture and liquid while coupled.

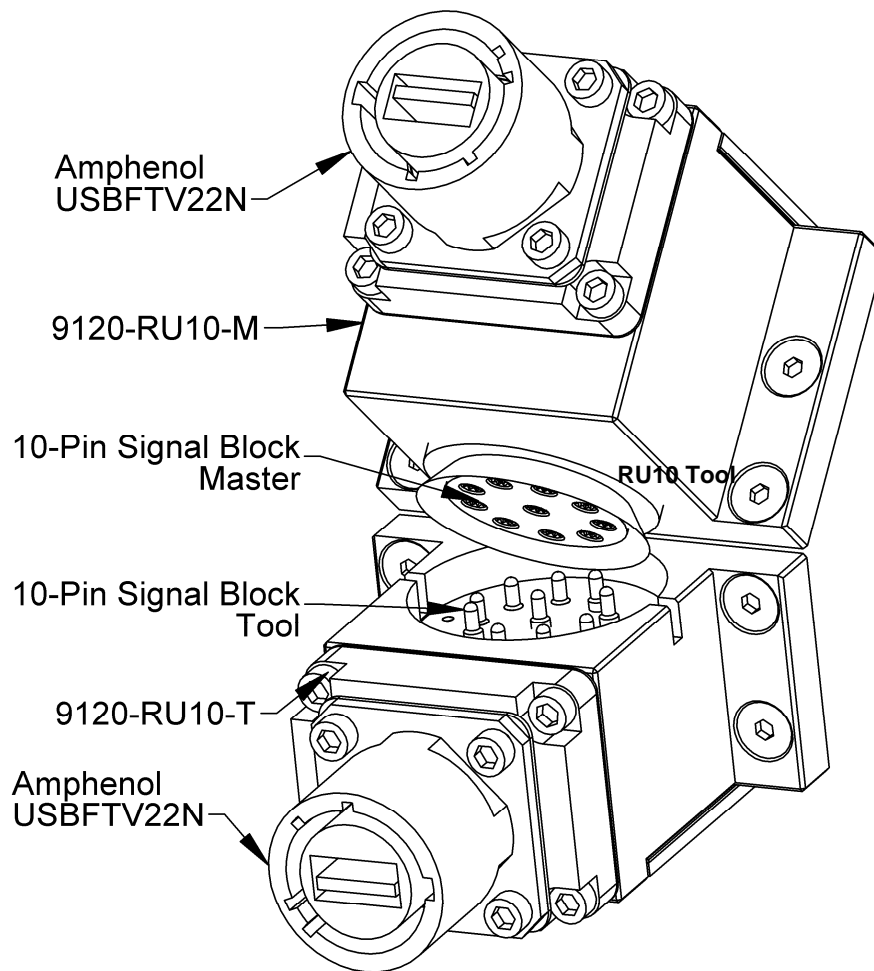

Figure 1.1—Electrical Modules (RU10-M, RU10-T shown)

2. Installation

The control/signal modules are typically installed by ATI prior to shipment. The steps below outline the field installation or removal as required.



DANGER: Power and air should always be removed prior to maintenance or repair.

2.1 Installing

1. It may be necessary to clean the mounting surface on the tool changer prior to installing the module in order to remove any debris that may be present.
2. Apply Loctite-222[®] (or similar) thread locker to the socket head cap screws and tighten using a hex key.

2.2 Removal

1. All customer connections up to the module need to be disconnected.
2. Remove the socket head cap screws and pull the module off the tool changer.

3. Operation

The primary current module is designed to carry USB signals to various industrial devices, providing a separable joint in the signal wiring. To maximize the service life of these components the following points should be observed:

1. Properly route and secure all cables, particularly on the Master. Failure to observe this point may result in premature failure of the industrial electrical connectors. Poor cable routing can also result in wires and cable being pinched in the joint between the tool changer halves.
2. Always protect the un-used Tool modules when not coupled to a Master module. Dust, debris, and weld spatter can contaminate the contact tips resulting in arcing and a significant decrease in contact life.
3. The recommended maximum cable length for best result should be kept to 5m on Master side and 1.5m on Tool side. The wires will be non-shielded discrete for the power and ground, and twisted shielded for the Data pair inside the RU10 module
In general, ATI cannot guarantee proper operation with a cable length beyond the maximum value defined in the USB specification (=5m).

4. Maintenance

Contact pins on the control module should be inspected and cleaned periodically to ensure electrical continuity is maintained. Care should be taken not to bend or pull out the contacts when cleaning. Do not use an abrasive media to clean the contact pins as erosion may occur to the contact surface.

5. Troubleshooting

Symptom	Possible Cause / Correction
Loss of Communication	Check/Replace cabling up- and down-stream of the tool changer modules. Inspect signal module contact pins for debris/wear.

6. Recommended Spare Parts

Assembly	Part Number	Description
RU10 Electrical Module Master	9120-RU10-M	Master Electrical Module Assembly
	4010-0000082-01	V-Ring
RU10 Electrical Module Tool	9120-RU10-T	Tool Electrical Module Assembly

7. Specifications

<u>Electrical Module</u>	RU10-M / RU10-T	Electrical Module with -- signal pass-through for customer use.
Weights	0.50 lbs. (0.23 kg) 0.35 lbs. (0.16 kg)	RU10 Master RU10 Tool
Pass-Through Signals	10 @ 5 amp 250 VAC / 600VDC	Master-side Customer interface connector, Amphenol – USBFTV22N. Tool-side Customer Interface connector, MS3102E22-23S. Amphenol – USBFTV22N.

8. Drawings

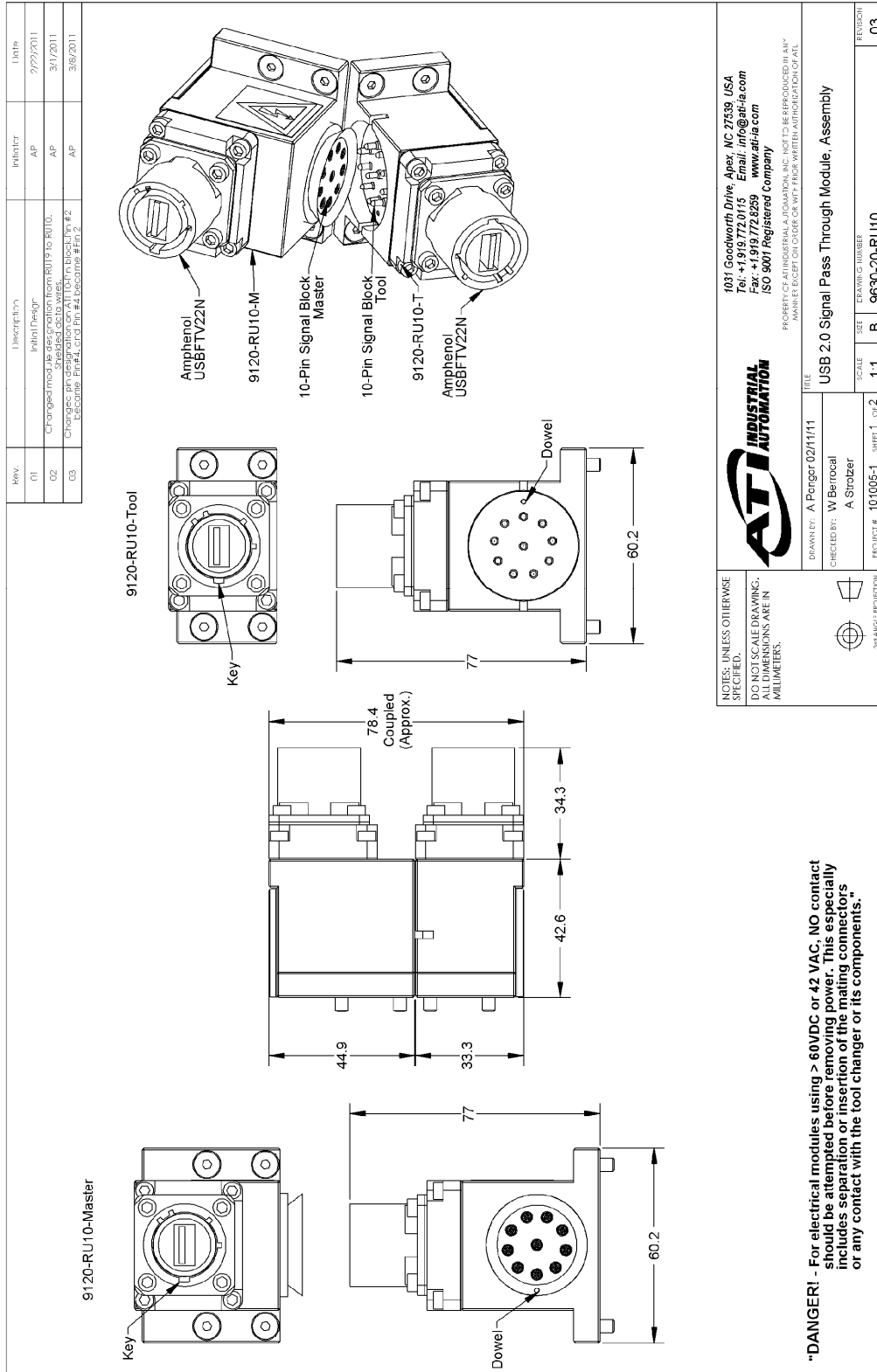

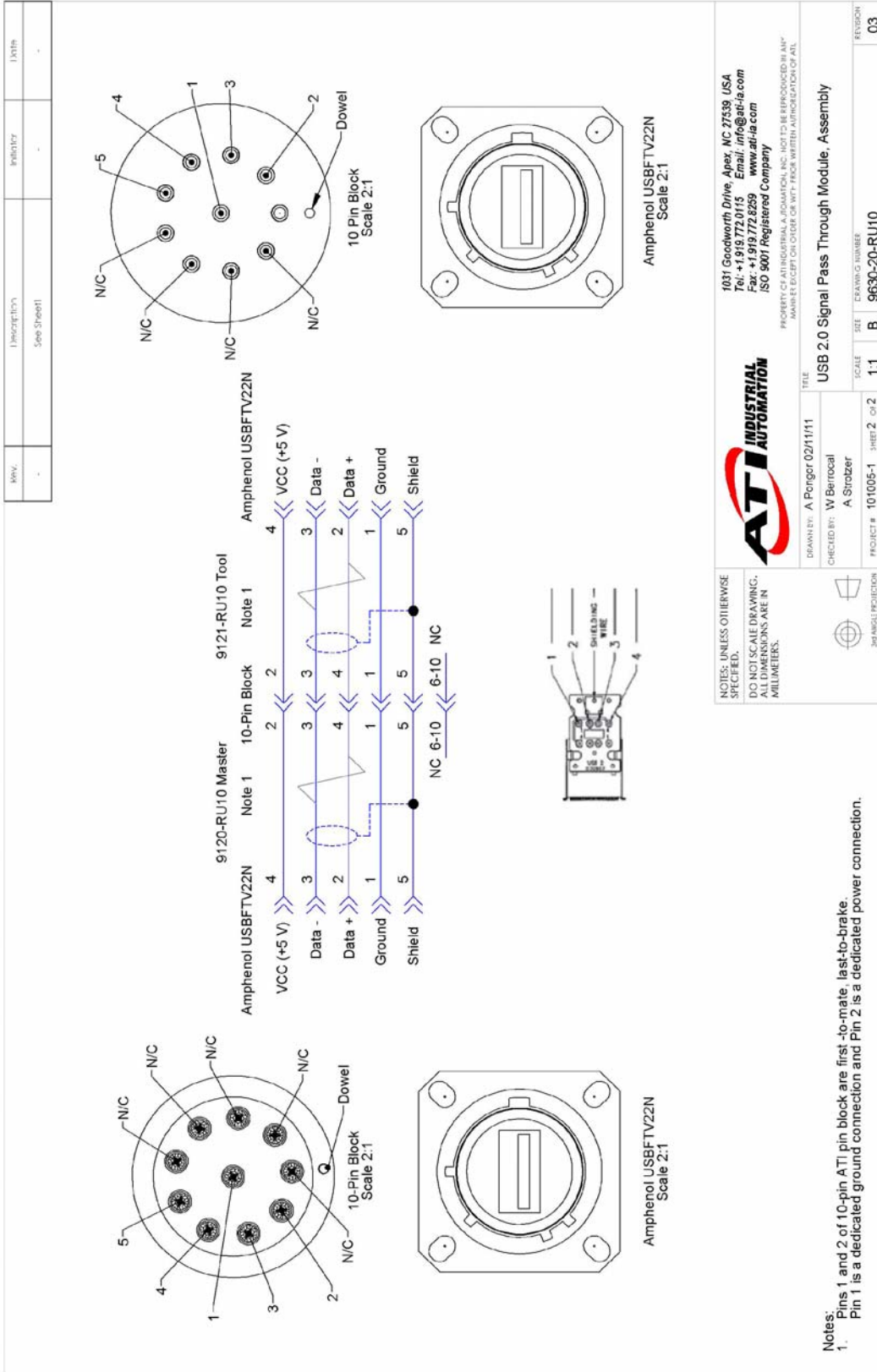

Notes:
 1. Pins 1 and 2 of 10-pin ATi pin block are first-to-mate, last-to-brake.
 Pin 1 is a dedicated ground connection and Pin 2 is a dedicated power connection.