

Table of Contents

- D. Air ModulesD-2**
- AK2-M/T, AR2-M/T—Air Module.....D-2**
- 1. Product OverviewD-2**
- 2. InstallationD-3**
 - 2.1 Installing Modules D-3**
 - 2.2 Removing Modules D-4**
- 3. OperationD-5**
- 4. Maintenance.....D-5**
- 5. Troubleshooting and Service ProceduresD-6**
 - 5.1 Troubleshooting D-6**
 - 5.2 Service Procedures..... D-7**
 - 5.2.1 Master Side Self-Sealing Valve D-7**
 - 5.2.2 Tool Side Self-Sealing Valve D-9**
- 6. Serviceable PartsD-10**
- 7. SpecificationsD-11**
- 8. DrawingsD-11**

D. Air Modules

AK2-M/T, AR2-M/T—Air Module

1. Product Overview

Air modules provide air utility and are attached to the Master and Tool plates. When the Tool Changer is coupled, the Master module passes the air supply to the Tool module for use by the customer tooling. Significant forces are encountered when using these modules. Assistance from the robot may be required to overcome these forces when coupling the Tool Changer.

NOTICE: The Master and Tool modules contain self-sealing valves. Do not use self-sealing valves for vacuum utility.

Table 1.1—Air Modules		
Module	Air Ports	Valves
AK2-M	(10) G ¼ (BSPP)	(10) self-sealing air
AK2-T	(10) G ¼ (BSPP)	
AR2-M	(10) Rc ¼ BSPT	
AR2-T	(10) Rc ¼ BSPT	

Figure 1.1—Air Modules

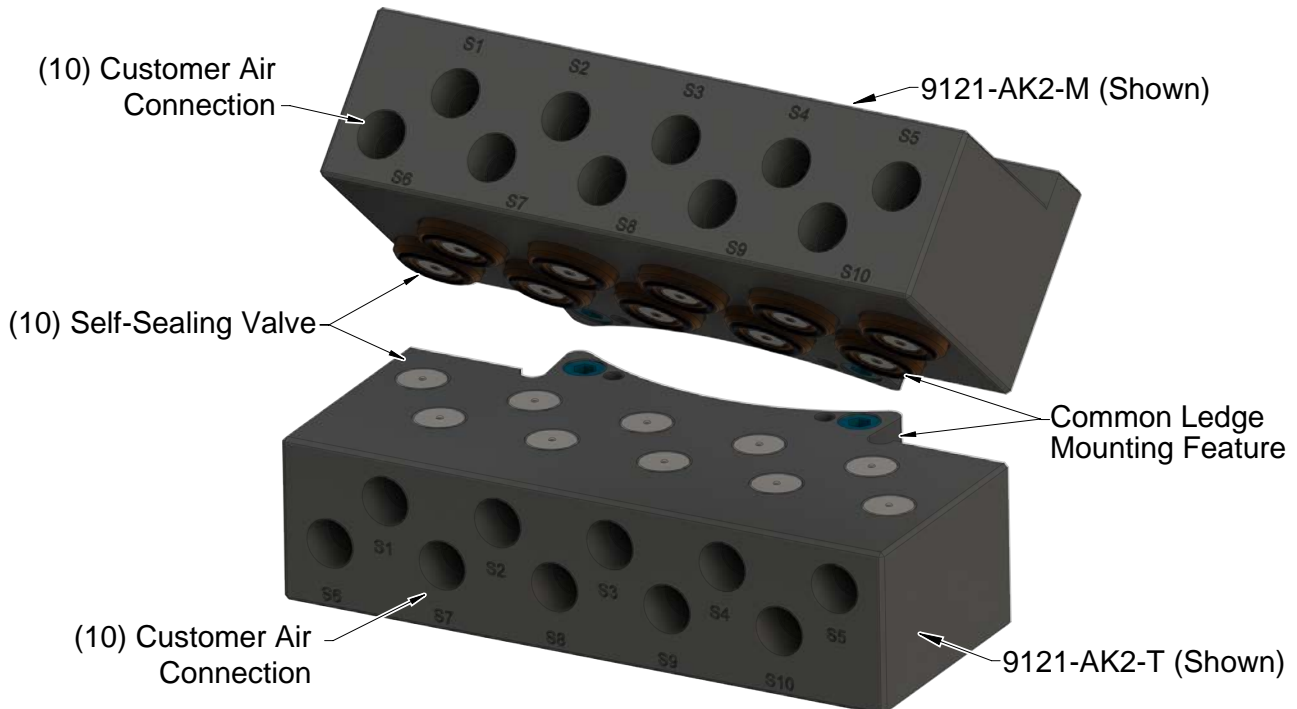

2. Installation

Air modules are typically installed by ATI prior to shipment. Use the following steps to install or remove air modules.

For more information, refer to [Section 8—Drawings](#).



WARNING: Do not perform maintenance or repair(s) on the Tool Changer or modules unless the Tool is safely supported or placed in the tool stand, all energized circuits (for example: electrical, air, water, etc.) are turned off, pressurized connections are purged and power is discharged from circuits in accordance with the customer specific safety practices and policies. Injury or equipment damage can occur with the Tool not placed and energized circuits on. Place the Tool in the tool stand, turn off and discharge all energized circuits, purge all pressurized connections, and verify all circuits are de-energized before performing maintenance or repair(s) on the Tool Changer or modules.



WARNING: All pneumatic fittings and tubing must be capable of withstanding the repetitive motions of the application without failing. The routing of electrical and pneumatic lines must minimize the possibility of over stressing, pullout, or kinking the lines. Failure to do so can cause critical electrical and/or pneumatic lines to malfunction and might result in injury to personnel or damage to equipment.



CAUTION: Thread locker applied to fasteners must not be used more than once. Fasteners might become loose and cause equipment damage. Always apply new thread locker when reusing fasteners.

2.1 Installing Modules

See [Figure 2.1](#).

Tools required: 5 mm hex key, torque wrench

Supplies required: clean rag, Loctite® 242

1. Place the Tool in a secure location.
2. Uncouple the Master and Tool plates.
3. Turn off and de-energize all energized circuits (for example: electrical, pneumatic, and hydraulic circuits).
4. Wipe down the mounting surfaces with a clean rag.
5. Place the module into the appropriate location on the Tool Changer or Utility Coupler body. Align the module with the Tool Changer using the dowels in the bottom of the ledge feature.
6. Apply Loctite 242 to the supplied M6 socket head cap screws. Using a 5 mm hex key, install the (2) M6 socket head cap screws securing the module to the Tool Changer or Utility Coupler and tighten to 89 in-lbs (10.0 Nm).
7. Ensure the air connectors are clean and connect to the module.
8. Safely resume normal operation.

Figure 2.1—Installation and Removal of the Module

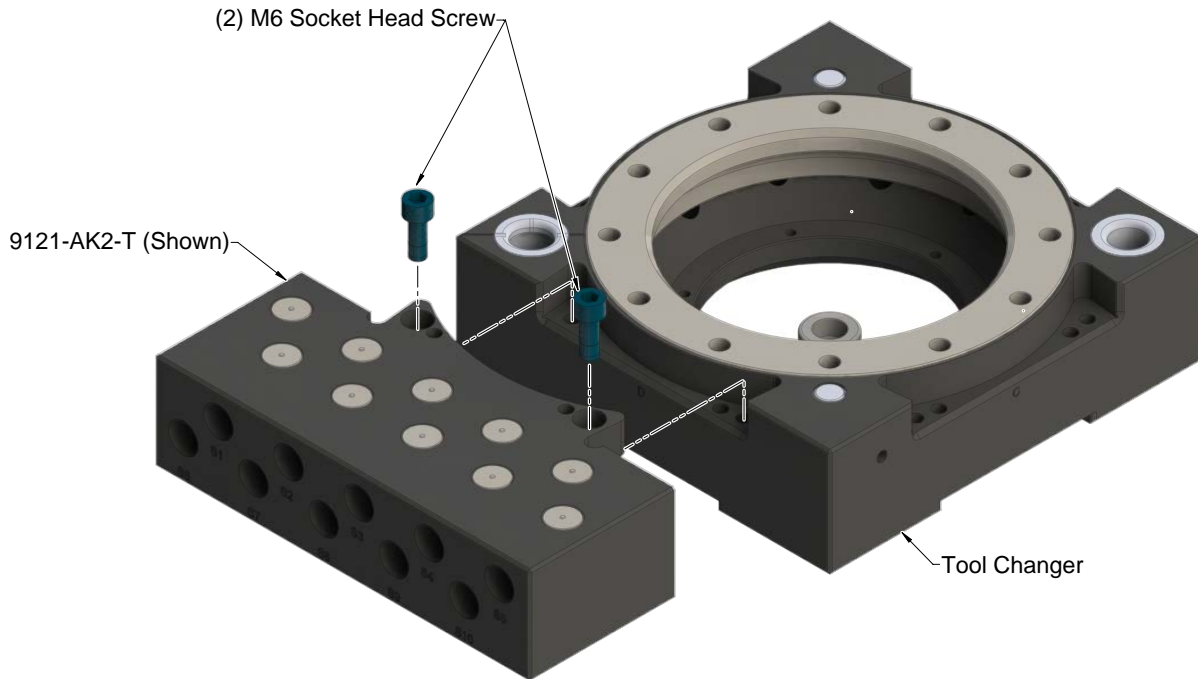

2.2 Removing Modules

Tools required: 5 mm hex key

Supplies required: clean rag, paint marker

1. Place the Tool in a secure location.
2. Uncouple the Master and Tool plates.
3. Turn off and de-energize all energized circuits (for example: electrical, pneumatic, and hydraulic circuits).

NOTICE: Debris can be expelled at high velocity during the purge, take all required safety precautions.

4. All customer plumbing connections to the module must be purged.
 - a. Verify that the supply lines are turned off.
 - b. Cover the valves with a rag for safety.
 - c. Manually actuate the self-sealing valves to purge the line pressure.
5. Use a paint marker to indicate where the module is to be re-installed.
6. Disconnect air plumbing to the module.
7. Remove the (2) M6 socket head cap screws using a 5 mm hex key.
8. Remove the module from the Tool Changer or Utility Coupler.

3. Operation

Air modules pass air utilities from the Master to the Tool for use by the customer’s tooling. Unlike pass-through ports, self-sealing valves prevent the air circuits from discharging, which eliminates the need to close upstream circuits. Self-sealing valves and pass-through ports operate at a maximum pressure of 100 psi (6.9 bar).

NOTICE: If the air pressure is not released from the Tool side of the pass-through port, debris can be expelled at high velocity when the Tool Changer uncouples. Take all required safety precautions.

4. Maintenance

Perform maintenance to maximize the operational life of the module.



WARNING: Do not perform maintenance or repair(s) on the Tool Changer or modules unless the Tool is safely supported or placed in the tool stand, all energized circuits (for example: electrical, air, water, etc.) are turned off, pressurized connections are purged and power is discharged from circuits in accordance with the customer specific safety practices and policies. Injury or equipment damage can occur with the Tool not placed and energized circuits on. Place the Tool in the tool stand, turn off and discharge all energized circuits, purge all pressurized connections, and verify all circuits are de-energized before performing maintenance or repair(s) on the Tool Changer or modules.

A preventive maintenance schedule and checklist are provided in the following tables:

Table 4.1—Preventive Maintenance Schedule	
Inspection Schedule	Action Required
Weekly	Clean and inspect
6 months or 500,000 cycles	Seal replacement

Table 4.2—Checklist
Weekly Maintenance:
<ul style="list-style-type: none"> <input type="checkbox"/> Clean mating surfaces. <input type="checkbox"/> Inspect modules for air leaks. Replace components as necessary.
6 months or 500,000 cycle Maintenance:
<ul style="list-style-type: none"> <input type="checkbox"/> Remove and replace self-sealing valve O-ring seals in both the Master and Tool Module. During O-ring and seal replacement inspect valve stem and dowel pin for straightness. During O-ring and seal replacement re-lubricate bores. Refer to Section 5.2.1—Master Side Self-Sealing Valve and Section 5.2.2—Tool Side Self-Sealing Valve. <input type="checkbox"/> Inspect the mounting fasteners for tightness, tighten if loose refer to Section 2.1—Installing Modules.

5. Troubleshooting and Service Procedures

The following section provides troubleshooting information to help diagnose conditions with the Tool Changer or air module and service procedures to help resolve these conditions.



WARNING: Do not perform maintenance or repair(s) on the Tool Changer or modules unless the Tool is safely supported or placed in the tool stand, all energized circuits (for example: electrical, air, water, etc.) are turned off, pressurized connections are purged and power is discharged from circuits in accordance with the customer specific safety practices and policies. Injury or equipment damage can occur with the Tool not placed and energized circuits on. Place the Tool in the tool stand, turn off and discharge all energized circuits, purge all pressurized connections, and verify all circuits are de-energized before performing maintenance or repair(s) on the Tool Changer or modules.

5.1 Troubleshooting

Refer to the following table for troubleshooting information:

Table 5.1—Troubleshooting		
Symptom	Possible Cause	Correction
Air leakage	Damaged/Worn seals	Replace seals. Refer to Section 5.2.1—Master Side Self-Sealing Valve and Section 5.2.2—Tool Side Self-Sealing Valve .
	Debris blocking valve seal	Clean in and around valve components. Ensure air stream is free of large particulates, filter as necessary.
	Bent stem	Replace stem. Check module attachment to Tool Changer. Check robot program and ensure parallel approach trajectory during Tool Changer coupling. Refer to Section 5.2.1—Master Side Self-Sealing Valve and Section 5.2.2—Tool Side Self-Sealing Valve .
	Corrosion	Consult ATI for assistance.
Reduced flow	Air hose supply/return lines or connections damaged or blocked	Inspect supply/return hoses and connections for damage or blockage, clean/repair/replace as necessary.
	Valve blockage	Inspect valve components and clean/repair as necessary. Refer to Section 5.2.1—Master Side Self-Sealing Valve and Section 5.2.2—Tool Side Self-Sealing Valve .
Modules unable to couple	Debris between Tool Change Master and Tool plates or modules.	Clean debris from between Master and Tool Plates and modules.
	Bent stem, dowel pin	Replace stem, dowel pins as necessary. Check module attachment to Tool Changer. Check robot program and ensure parallel approach trajectory during Tool Changer coupling. Refer to Section 5.2.1—Master Side Self-Sealing Valve and Section 5.2.2—Tool Side Self-Sealing Valve .

5.2 Service Procedures

The following service procedures provide instructions for component replacement and adjustment.

5.2.1 Master Side Self-Sealing Valve

Parts required: Refer to [Section 8—Drawings](#)

Tools required: 2.5 mm hex key, torque wrench

Supplies required: Clean rag, Magnalube G lubricant

1. Place the Tool in a secure location.
2. Uncouple the Master and Tool plates.
3. Turn off and de-energize all energized circuits (for example: electrical, pneumatic, and hydraulic circuits).

NOTICE: Debris can be expelled at high velocity during the purge, take all required safety precautions.

4. Purge and disconnect all customer plumbing connections to the module.
 - a. Turn the supply lines off.
 - b. Cover the valves with a rag for safety.
 - c. Manually actuate the module's self-sealing valves to purge the line pressure. Note: Debris can be expelled at high velocity during the purge, take all required safety precautions.
5. Depending on the type of service or repair, connections to the module might also need to be disconnected.
6. Remove the valve stem using a 2.5 mm hex key. Do not strip the hex on the valve stem during removal.
7. Remove the check valve piston and spring. Clean any lubrication from the check valve piston, valve stem, spring, and bore in the module housing using a clean rag.
8. Inspect the valve stem for straightness, and replace, if bent.
9. Inspect the o-rings and u-cup seal on the valve stem and check valve piston for wear and damage. Replace components that are damaged or worn.
10. Inspect the spring in the assembly and replace if damaged or worn.

Figure 5.1—Master Self-Sealing Valve

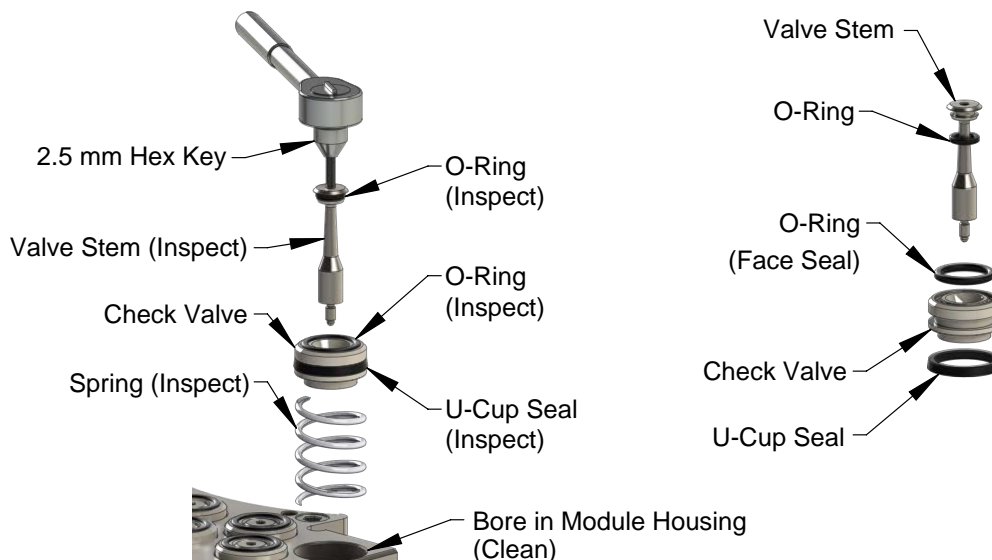

11. Lubricate the bore in the module housing with Magnalube G (Teflon/Petroleum based grease).

NOTICE: Do not lubricate the O-ring face seal until after installation. Lubricating the O-ring before installation can cause the O-ring to blow out during coupling and uncoupling.

12. If replacing seals, lubricate the valve stem O-ring and the check valve piston U-cup seal with Magnalube G (Teflon/Petroleum based grease).

13. Install the O-ring on the valve stem.

14. Install the U-cup seal on the check valve. Do not get lubrication in the face seal groove in the check valve.

15. Install the non-lubricated O-ring (face seal) into the check valve.

16. Install the spring into the bore in the module housing, seat the check valve on the spring.

17. If the threaded end of the valve stem does not have pre-applied adhesive, apply Loctite 7649 primer and then Loctite 222 or similar thread locker to the threaded end of the valve stem. If the module housing is stainless steel, also add Loctite 7649 primer to the housing threads.

Figure 5.2—Master Self-Sealing Valve Installation

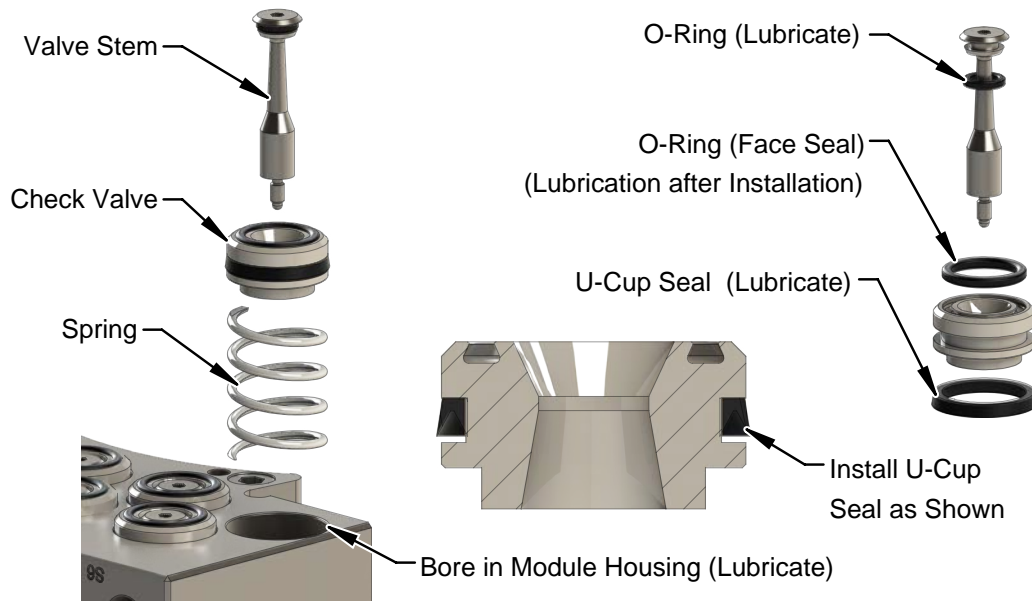

18. Install the valve stem. The check valve piston must be pushed down flush with the mating surface of the Master housing in order to install the threaded end of the valve stem. Do not damage the U-cup seal around the check valve piston. A small, flat-head screwdriver can be used to ensure that the U-cup seal is fully located in the recess and not folded over itself prior to screwing in the valve stem. Tighten the stem to 10 in-lbs (1.1 Nm).

19. Lubricate the installed O-ring (face seal) with Magnalube G (Teflon/Petroleum based grease).

20. Safely resume normal operation.

5.2.2 Tool Side Self-Sealing Valve

Parts required: Refer to [Section 8—Drawings](#)

Tools required: 10 mm hex key, Torque wrench

Supplies required: Clean rag, Magnalube G lubricant

1. Place the Tool in a secure location.
2. Uncouple the Master and Tool plates.
3. Turn off and de-energize all energized circuits (for example: electrical, pneumatic, and hydraulic circuits).

NOTICE: Debris can be expelled at high velocity during the purge, take all required safety precautions.

4. All customer plumbing connections to the module must be purged.
 - a. Verify that the supply lines are turned off.
 - b. Cover the valves with a rag for safety.
 - c. Manually actuate the self-sealing valves to purge the line pressure.
5. If required disconnect connections to the module.

NOTICE: You might need to remove the Tool side module to access the plug.

6. Remove the plug assembly from the bottom of the air module using a 10 mm hex key.
7. Remove the spring and valve assembly from the housing.

Figure 5.3—Tool Self-Sealing Valve (Disassembly)

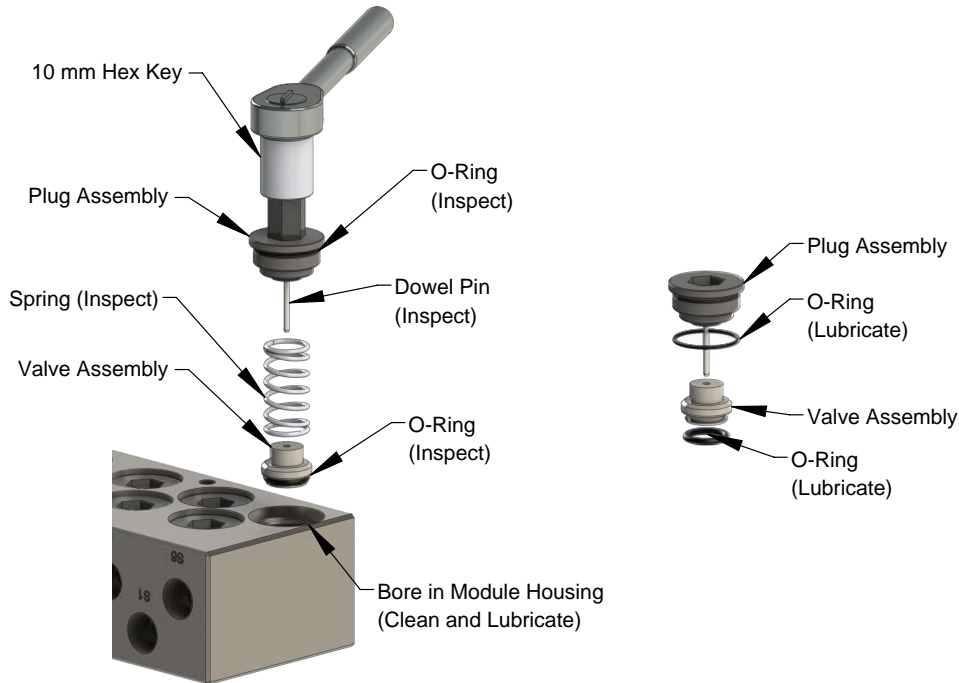

8. Clean all lubrication from the plug assembly, valve assembly, spring, and bore in the housing using a clean rag.
9. Inspect the dowel pin that is contained in the plug assembly for straightness. Replace the plug assembly if the dowel pin is bent.
10. Inspect the O-rings on the plug and valve assemblies, replace if worn or damaged.
11. Inspect the spring in the assembly and replace if worn or damaged.

12. If replacing the O-rings, lubricate both new O-rings with Magnalube G (Teflon/Petroleum based grease).
13. Install the O-rings on the plug assembly and the valve assembly.

Figure 5.4—Tool Self-Sealing Valve (Assembly)

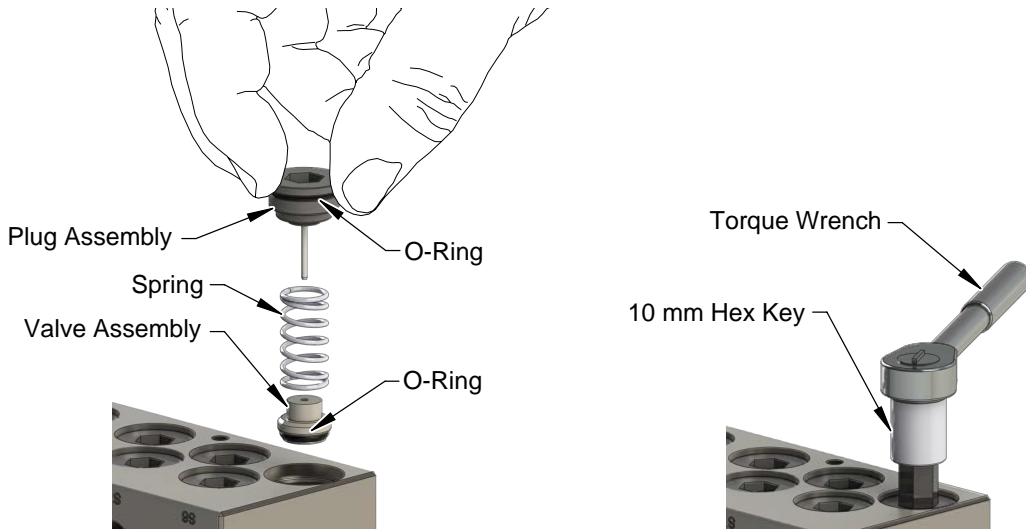

14. Install the check valve piston, make sure it is seated properly in the housing.
15. Install the spring into the housing, make sure it is installed over the step on the check valve.

CAUTION: Do not use excess force when installing the plug assembly into the housing. Using excessive force can damage the O-ring and strip the threads on the plug assembly. Thread the plug assembly into the Tool housing by hand, until several threads are engaged into the housing. Then use a 10 mm hex key to complete the installation. Torque the plug to 30 in-lbs (3.39 Nm).

16. Carefully install the plug assembly aligning the dowel pin into the check valve piston. Thread the plug assembly into the housing by hand until several threads are engaged in the housing.
17. Tighten the plug assembly using a 10 mm hex key to 30 in-lbs (3.39 Nm).
18. Verify the check valve piston is seated properly in the housing.
19. Safely resume normal operation.

6. Serviceable Parts

See the drawings in [Section 8—Drawings](#) of this manual.

Table 6.1—Master Module Mounting Hardware		
Part Number	QTY	Description
3500-1066020-21A	2	M6 x 20 Socket Head Cap Screw, SS, ND Microspheres

Table 6.2—Tool Module Mounting Hardware		
Part Number	QTY	Description
3500-1066020-21A	2	M6 x 20 Socket Head Cap Screw, SS, ND Microspheres

7. Specifications

Table 7.1—AK2 Module Specifications	
9121 AK2-M	Pneumatic Master module with (10) G ¼ self-sealing ports
9121-AK2-T	Pneumatic Tool module with (10) G ¼ self-sealing ports
Materials of Construction	Various - Stainless Steel valve components, aluminum housing, Nitrile seals
Weight:	
Master Module	2.52 lbs. (1.14 kg)
Tool Module	2.1 lbs. (0.95 kg)
Self-Sealing Valves:	
Quantity	10
Air Pressure	Maximum pressure of 100 psi (6.9 bar)
Cv, Min	1.4
Customer Port Connection	G ¼

Table 7.2—AR2 Module Specifications	
9121-AR2-M	Pneumatic Master module with (10) Rc ¼ BSPT self-sealing ports
9121-AR2-T	Pneumatic Tool module with (10) Rc ¼ BSPT self-sealing ports
Materials of Construction	Various - Stainless Steel valve components, aluminum housing, Nitrile seals
Weight:	
Master Module	2.52 lbs. (1.14 kg)
Tool Module	2.1 lbs. (0.95 kg)
Self-Sealing Valves:	
Quantity	10
Air Pressure	Maximum pressure of 100 psi (6.9 bar)
Cv, Min	1.4
Customer Port Connection	Rc 1/4 BSPT

8. Drawings

Drawings are available on the [ATI website](#) or by contacting an ATI representative.