

Table of Contents

C. Control and Signal Modules	C-2
Integrated Single Solenoid Valve Adapters with Valve Signal Pass Through	C-2
1. Product Overview	C-2
2. Installation	C-4
2.1 Valve Adapter Installation for QC-113, QC-210, QC-213, GL6L, GL7L	C-4
2.2 Valve Adapter Removal for QC-113, QC-210, QC-213, GL6L, GL7L0	C-5
2.3 Valve Adapter Installation for QC-310, QC-313, QC-510, QC-1210	C-6
2.4 Valve Adapter Removal for QC-310, QC-313, QC-510, QC-1210	C-7
2.5 Tool Adapter Assembly Installation	C-7
2.6 Tool Adapter Assembly Removal	C-8
2.7 Pneumatic Connections	C-8
2.8 Electrical Connections	C-8
3. Operation	C-9
4. Maintenance	C-9
5. Troubleshooting and Service Procedures	C-10
5.1 Troubleshooting	C-11
5.1.1 Solenoid Valve Manual Override Procedure	C-12
5.2 Service Procedures	C-13
5.2.1 Exhaust Muffler Replacement	C-13
5.2.2 Inlet Filter Replacement	C-14
6. Serviceable Parts	C-15
6.1 Single Solenoid Valve Adapters with Valve Pass Through	C-15
6.2 Tool Adapter Assembly	C-15
7. Specifications	C-16
8. Drawings	C-17

C. Control and Signal Modules

Integrated Single Solenoid Valve Adapters with Valve Signal Pass Through

1. Product Overview

Valve adapters are required to provide an air supply to the compatible Tool Changer or Utility Coupler Master for actuation of the locking mechanism. Valve adapters come outfitted with an integrated single-solenoid valve and mount to Flat ‘A’. Control of the integrated valve is accomplished using the valve signal pass through connector to the control/signal module. The unlatch signal sent to the control/signal module is transmitted to the valve adapter using a small, internal pin block. *Figure 1.1* shows the control/signal module to valve adapter electrical interface. Many variations of the valve adapter with valve signal pass through are available, depending upon the Tool Changer size and type of porting required by the customer (see *Table 1.1* and *Section 8—Drawings* for a complete listing of available adapters and customer drawings).

Figure 1.1—Valve Pass Through Connection

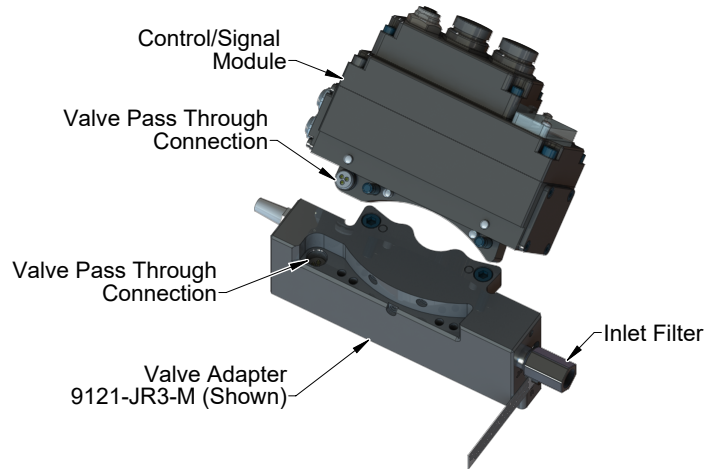
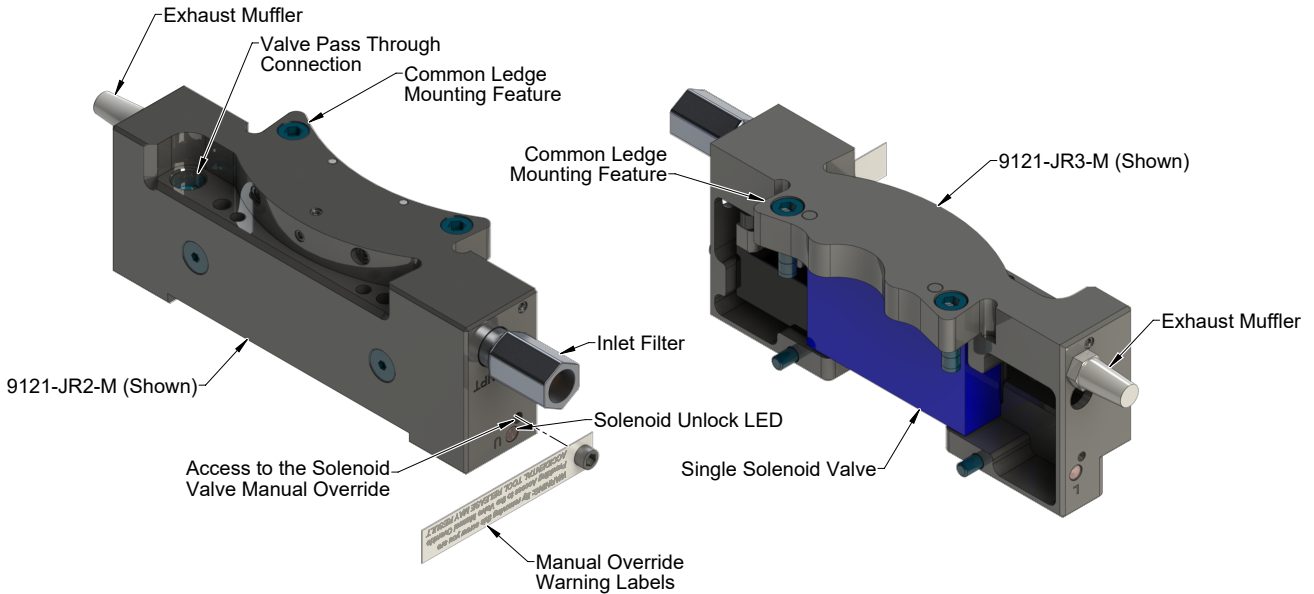

Table 1.1—Valve Adapters with a Single Solenoid and Valve Pass Through Models

Valve Adapter	Description	Air Port Size	Compatible Tool Changer or Utility Coupler models
9121-JP7-M	Single Solenoid	Rc 1/4 (BSPT)	QC-310, QC-313, QC-510, QC-1210
9121-JR2-M	Single Solenoid	1/4" NPT	QC-113, QC-210, QC-213, GL6L, GL7L
9121-JR3-M	Single Solenoid	1/4" NPT	QC-310, QC-313, QC-510, QC-1210

The valve adapter provides a ledge mount for the control/signal Master module and provides a single air port connection for the customer air supply. Lock and Unlock air connections to the Tool Changer or Utility Coupler are provided through ports in the ledge mount, O-rings in the body seal the connection. The valve adapter is equipped with an exhaust muffler, single solenoid valve, and an LED indicator for the solenoid unlock position, refer to [Figure 1.2](#). Access to the solenoid valve manual override is provide through a screw in the aluminum housing, refer to [Section 5.1.1—Solenoid Valve Manual Override Procedure](#) for more information.

Figure 1.2—Valve Adapters with a Single Solenoid and Valve Pass Through



A tool adapter assembly (9005-20-1192) is required for the Tool side which provides the proper spacing and a ledge mount for the control/signal Tool module.

Figure 1.3—Tool Adapters Assembly

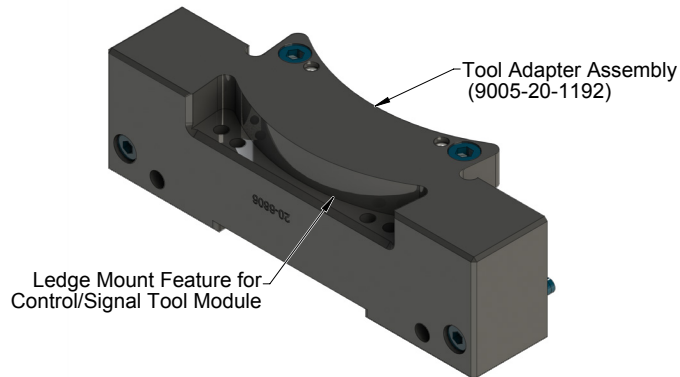

2. Installation

Valve adapters and tool adapter assemblies are typically installed by ATI prior to shipment. The following procedure outline the installation and removal procedures.



WARNING: Do not perform maintenance or repair(s) on the Tool Changer or modules unless the Tool is safely supported or placed in the tool stand, all energized circuits (for example: electrical, air, water, etc.) are turned off, pressurized connections are purged and power is discharged from circuits in accordance with the customer specific safety practices and policies. Injury or equipment damage can occur with the Tool not placed and energized circuits on. Place the Tool in the tool stand, turn off and discharge all energized circuits, purge all pressurized connections, and verify all circuits are de-energized before performing maintenance or repair(s) on the Tool Changer or modules.

2.1 Valve Adapter Installation for QC-113, QC-210, QC-213, GL6L, GL7L

Tools required: 5 mm hex key, 3 mm hex key, torque wrench

Supplies required: clean rag

1. Place the Tool in a secure location.
2. Turn off and de-energize all energized circuits (for example: electrical, pneumatic, and hydraulic circuits).
3. Wipe down the mounting surfaces with a clean rag.
4. (2) O-rings are required on the Master side Flat 'A' interface. Make sure these O-rings are present and lightly lubricated.
5. Using the ledge feature to place the valve adapter adjacent to the 'Flat A' mounting surface. Align the valve adapter using the dowels in the bottom of the ledge feature. Apply Loctite 242 to the supplied M6 socket head cap screws. Secure the valve adapter using the M6 socket head cap screws and tighten to 70 in-lbs (7.9 Nm).
6. Apply Loctite 222 to the (2) supplied M5 socket flat head cap screws. Secure the valve adapter using the fasteners, tighten the M5 socket flat head cap screws to 28 in-lbs (3.2 Nm).

Figure 2.1—Valve Adapter Installation (QC-210 Shown)

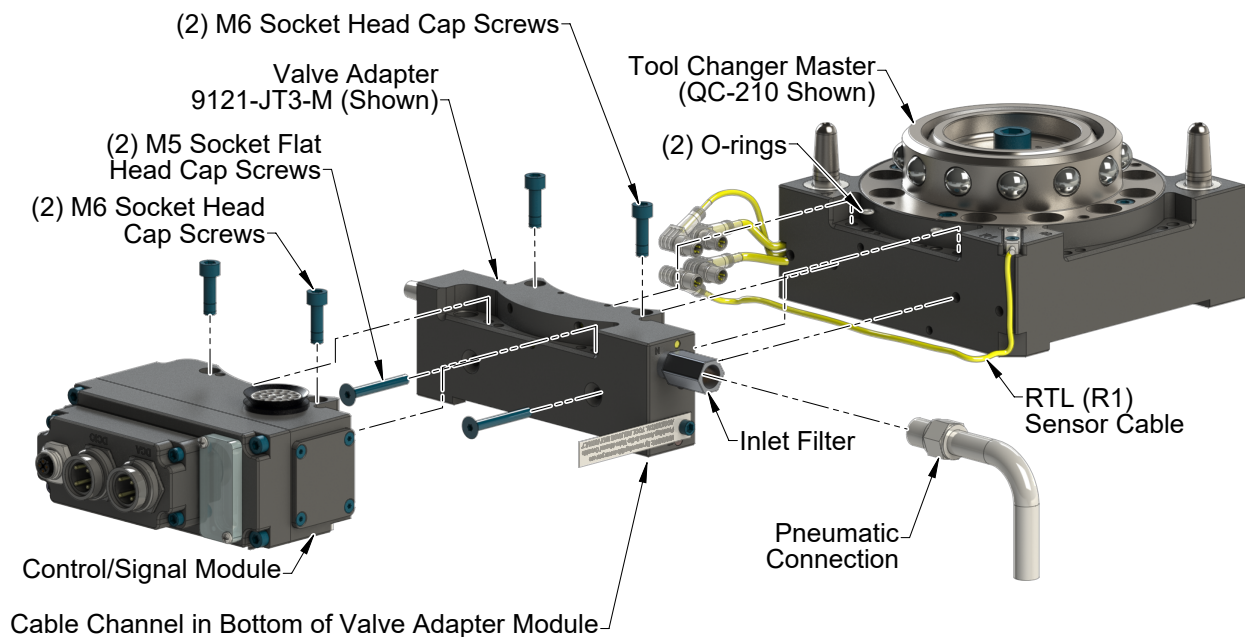

7. Route the RTL (R1) sensor cable through the cable channel in the bottom of the valve adapter.
8. Install the cleat from the control/signal module to retain the RTL (R1) sensor cable in the cable channel, use the (3) M5 socket flat head cap screws to secure the cleat. Tighten to 14 in-lbs (1.6 Nm).
9. Install inlet filter provided with valve adapter. ATI recommends using a thread sealant such as Loctite 569 or similar.
10. Make pneumatic connections to the inlet filter as required. Ensure that the connectors are cleaned prior to being secured as appropriate. ATI recommends using a thread sealant such as Loctite 569 or similar.

Figure 2.2—RTL (R1) Sensor Cable Routing

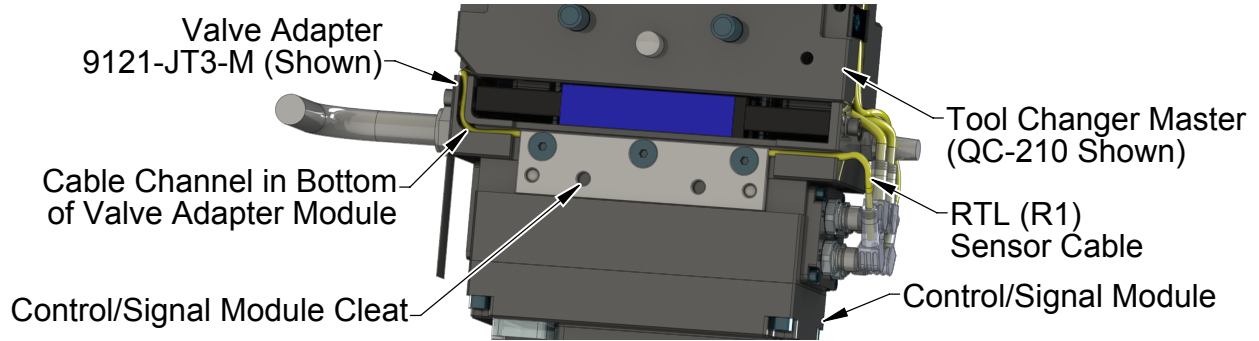

2.2 Valve Adapter Removal for QC-113, QC-210, QC-213, GL6L, GL7L0

NOTICE: Depending on maintenance or repair being performed, utilities to modules and Master plate may need to be disconnected.

Tools required: 5 mm hex key, 3 mm hex key

1. Place the Tool in a secure location.
2. Turn off and de-energize all energized circuits (for example: electrical, pneumatic, and hydraulic circuits).
3. Remove the control/signal module off the valve adapter. Refer to the control /signal module manual for instructions.
4. Remove the (3) M5 socket flat head cap screws securing the control/signal module cleat, remove the cleat. Refer to [Figure 2.1](#).
5. Remove the RTL (R1) sensor cable from the cable channel in the bottom of the valve adapter. Refer to [Figure 2.2](#).
6. Remove the (2) M5 socket flat head cap screws and the (2) M6 socket head cap screws and lift the valve adapter off the Tool Changer.
7. Make sure that the O-rings are retained at the Master side Flat 'A' mounting interface.

2.3 Valve Adapter Installation for QC-310, QC-313, QC-510, QC-1210

Tools required: 5 mm hex key, 4 mm hex key, torque wrench

Supplies required: clean rag

1. Place the Tool in a secure location.
2. Turn off and de-energize all energized circuits (for example: electrical, pneumatic, and hydraulic circuits).
3. Wipe down the mounting surfaces with a clean rag.
4. (2) O-rings are required on the Master side Flat 'A' interface. Make sure these O-rings are present and lightly lubricated.

NOTICE: Make sure the RTL (R1) sensor cable is in the cable channel in the Tool Changer body, so it will not get pinched when installing the valve adapter.

5. Using the ledge feature to place the valve adapter adjacent to the 'Flat A' mounting surface. Align the valve adapter using the dowels in the bottom of the ledge feature. Apply Loctite 242 to the supplied M6 socket head cap screws. Secure the valve adapter using the M6 socket head cap screws and tighten to 70 in-lbs (7.9 Nm).
6. Apply Loctite 222 to the (2) supplied M5 socket head cap screws. Secure the valve adapter using the fasteners and tighten the M5 socket head cap screws to 55 in-lbs (6.2 Nm).
7. Install inlet filter provided with valve adapter. ATI recommends using a thread sealant such as Loctite 569 or similar.
8. Make pneumatic connections to the inlet filter as required. Ensure that the connectors are cleaned prior to being secured as appropriate. ATI recommends using a thread sealant such as Loctite 569 or similar.

Figure 2.3—Valve Adapter Installation (QC-310 Shown)

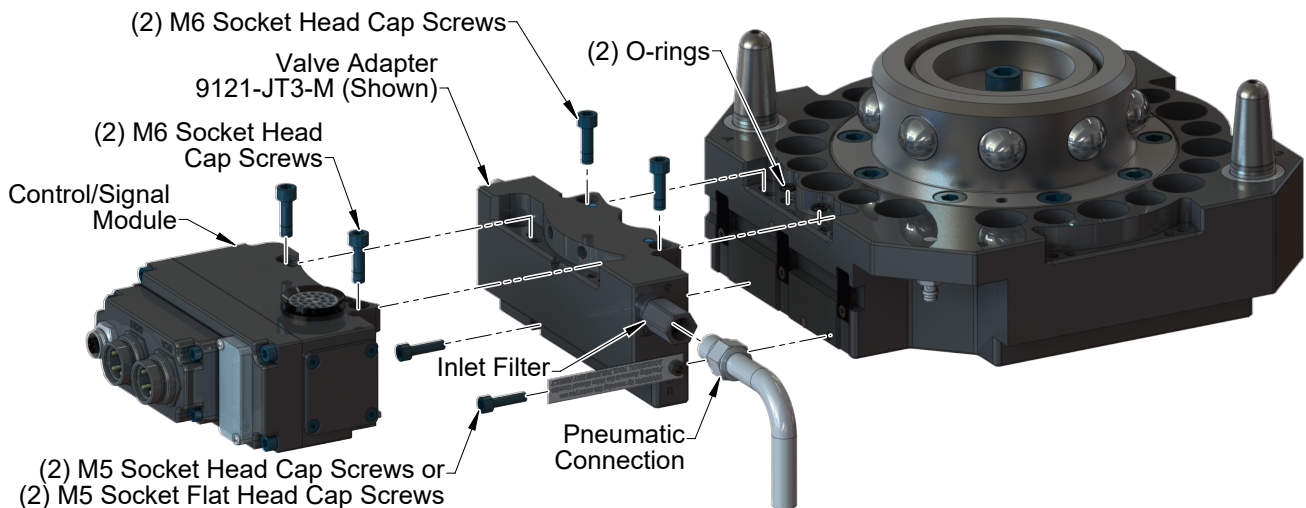

2.4 Valve Adapter Removal for QC-310, QC-313, QC-510, QC-1210

NOTICE: Depending on maintenance or repair being performed, utilities to modules and Master plate may need to be disconnected.

Tools required: 5 mm hex key, 4 mm hex key

1. Place the Tool in a secure location.
2. Turn off and de-energize all energized circuits (for example: electrical, pneumatic, and hydraulic circuits).
3. Remove the control/signal module off the valve adapter. Refer to the control /signal module manual for instructions.
4. Remove the (2) M5 socket head cap screws and the (2) M6 socket head cap screws and lift the valve adapter off the Tool Changer. Refer to [Figure 2.3](#).
5. Make sure that the O-rings are retained at the Master side Flat ‘A’ mounting interface.

2.5 Tool Adapter Assembly Installation

Tools required: 5 mm hex key, 4 mm hex key, torque wrench

Supplies required: clean rag

1. Place the Tool in a secure location.
2. Turn off and de-energize all energized circuits (for example: electrical, pneumatic, and hydraulic circuits).
3. Wipe down the mounting surfaces with a clean rag.
4. Using the ledge feature to place the tool adapter assembly adjacent to the ‘A’ mounting surface. Align the tool adapter assembly using the dowels in the bottom of the ledge feature. Apply Loctite 242 to the supplied M6 socket head cap screws. Secure the tool adapter using the M6 socket head cap screws and tighten to 89 in-lbs (10.0 Nm).
5. Apply Loctite 222 to the (2) supplied M5 socket head cap screws. Secure the tool adapter using the M5 socket head cap screws and tighten to 52 in-lbs (5.9 Nm).

Figure 2.4—Tool Adapter Assembly Installation

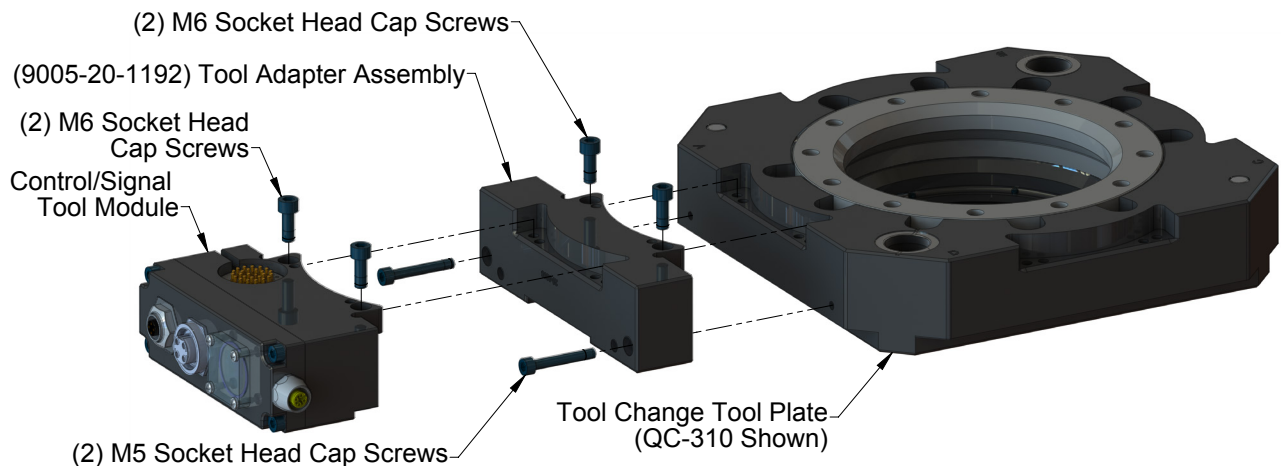

2.6 Tool Adapter Assembly Removal

NOTICE: Depending on maintenance or repair being performed, utilities to modules may need to be disconnected.

Tools required: 5 mm hex key, 4 mm hex key

1. Place the Tool in a secure location.
2. Turn off and de-energize all energized circuits (for example: electrical, pneumatic, and hydraulic circuits).
3. Remove the control/signal module off the valve adapter. Refer to the control /signal module manual for instructions.
4. Remove the (2) M5 socket head cap screws and the (2) M6 socket head cap screws and lift the tool adapter assembly off the Tool Changer or Utility Coupler (refer to [Figure 2.4](#)).

2.7 Pneumatic Connections

The air supply used for coupling and uncoupling the Tool Changer or Utility Coupler should be clean, dry, and non-lubricated. A supply pressure in the range of 60 to 100 psi (4.1–6.9 Bar) is acceptable for operation of the locking mechanism, with a setting of 80 psi suggested. The air should be filtered 40 micron or better. A single air supply is require to the valve adapter for Lock and Unlock air, refer to [Figure 2.3](#) for connection.



CAUTION: Do not use the Tool Changer in a fail-safe condition. Do not transport the Tool Changer in a fail-safe condition. Possible damage to the locking mechanism could occur. Re-establish air pressure to Tool Changer before returning to normal operations.

2.8 Electrical Connections

The electrical connection for valve control is made through an internal pin block as described in [Section 1—Product Overview](#) and detailed in drawings in [Section 8—Drawings](#). The control of the single-solenoid valve is integrated with an ATI-supplied control/signal module that is piggy-backed onto the valve adapter.

3. Operation

The unlatch command is sent to the control/signal module and passes through the internal pin block to control the solenoid valve. The single solenoid is spring loaded to the locked position and the unlatch command activates the solenoid to provide unlock air to the Tool Changer. When the unlatch command is made false (low) the solenoid returns to the lock position to provide lock air to the Tool Changer. The control/signal module can provide a customer specified safety functionality to prevent the accidental unlock of the Tool Changer unless the Tool is nested in the tool stand. Depending on the functionality of the control/signal module, the ability to unlock the Tool Changer unless the tool is coupled and in the tool stand may be denied. When this is the case the manual override is provided on the valve adapter, refer to [Section 5.1.1—Solenoid Valve Manual Override Procedure](#). Use of the manual override should be restricted to contingency situations and only when the robot and tool are in the stand or storage location. Actuation of the Unlatch valve manual override will result in Tool Changer release.



WARNING: Tool Changer release will occur with actuation of the Unlatch valve manual override. Use of the manual override is restricted to contingency situations. The Tool Changer and Tool should be in a stand or storage location prior to actuation of the manual override.

It is important that the valve adapter be supplied with clean, dry, non-lubricated air supplied between 60 and 100 psi (4.5–6.9 Bar) and filtered at 40 microns or better. Valve adapters are supplied with the Tool Changer to provide a fully integrated solution. The customer is only required to supply the valve adapter with a single air supply.

4. Maintenance

Valve adapters should require little maintenance. The only wear components are the valve itself and an exhaust muffler. Under normal operating conditions, the valve will last for millions of cycles. The exhaust muffler should be checked every 6 months of operation or more frequently in dirty environments to see if it is clogged.



WARNING: Do not perform maintenance or repair(s) on the Tool Changer or modules unless the Tool is safely supported or placed in the tool stand, all energized circuits (for example: electrical, air, water, etc.) are turned off, pressurized connections are purged and power is discharged from circuits in accordance with the customer specific safety practices and policies. Injury or equipment damage can occur with the Tool not placed and energized circuits on. Place the Tool in the tool stand, turn off and discharge all energized circuits, purge all pressurized connections, and verify all circuits are de-energized before performing maintenance or repair(s) on the Tool Changer or modules.

To check if the exhaust muffler is clogged remove the muffler and blow through the muffler. If it is difficult to blow or you can not blow through it at all replace the exhaust muffler. Refer to [Section 5.2.1—Exhaust Muffler Replacement](#).

5. Troubleshooting and Service Procedures



WARNING: Do not perform maintenance or repair(s) on the Tool Changer or modules unless the Tool is safely supported or placed in the tool stand, all energized circuits (for example: electrical, air, water, etc.) are turned off, pressurized connections are purged and power is discharged from circuits in accordance with the customer specific safety practices and policies. Injury or equipment damage can occur with the Tool not placed and energized circuits on. Place the Tool in the tool stand, turn off and discharge all energized circuits, purge all pressurized connections, and verify all circuits are de-energized before performing maintenance or repair(s) on the Tool Changer or modules.

Valve adapters with valve signal pass through are provided with an LED to indicate whether or not power is being supplied to the single-solenoid valve. This can be a valuable troubleshooting tool. [Figure 5.1](#) shows the location of the LED.

Figure 5.1—Valve Adapter UNLOCK LED Locations

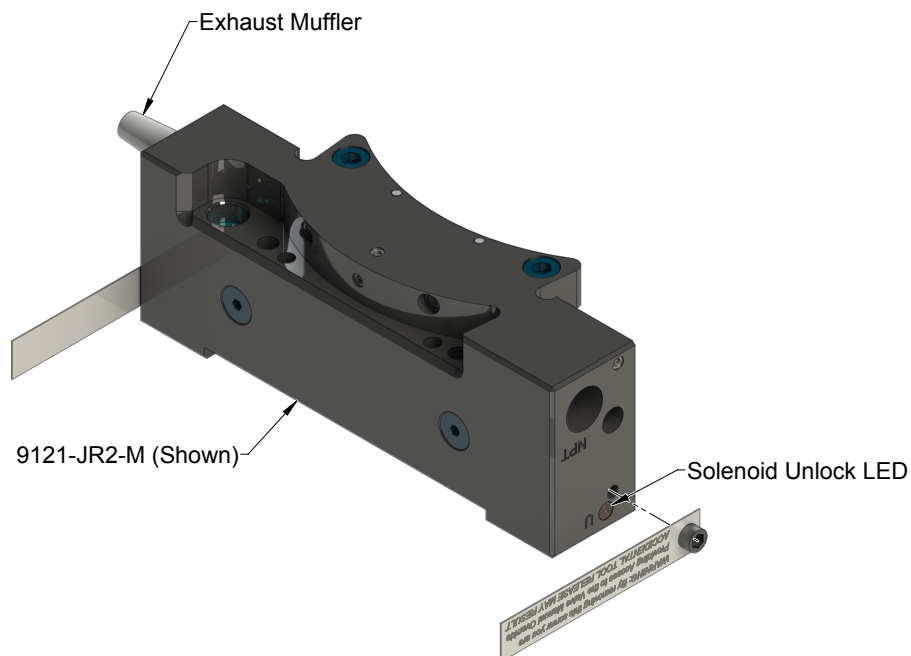

5.1 Troubleshooting

Follow the suggested actions listed in [Table 5.1](#) when attempting to troubleshoot the valve adapter. If issues persist, contact your closest ATI representative.

Table 5.1—Troubleshooting		
Symptom	Cause	Resolution
Tool Changer or Utility Coupler will not Lock / Unlock or operates slowly.	Exhaust muffler is clogged.	Check/Replace exhaust muffler; ensure clean air supply. Refer to Section 5.2.1—Exhaust Muffler Replacement .
	Inlet filter is clogged.	Check/Replace inlet filter; ensure clean air supply. Refer to Section 5.2.2—Inlet Filter Replacement .
	No or not enough air pressure on the pneumatic connection.	Make sure Pneumatic connection has minimum pressure, refer to Section 2.7—Pneumatic Connections .
	Loose valve adapter or O-rings leaking or missing.	Verify that the fasteners connecting the control/signal module to the valve adapter are properly tightened. If air still leaking, remove the valve adapter from the Tool Changer or Utility Coupler and check for air leaks, damaged or missing O-rings., Refer to Section 2.2—Valve Adapter Removal for QC-113, QC-210, QC-213, GL6L, GL7L0 or Section 2.4—Valve Adapter Removal for QC-310, QC-313, QC-510, QC-1210 .
	No power is supplied to the Solenoid valve.	Monitor UNLOCKED LED to verify power is supplied to valve. If the LED does not light, verify valve power supply at control/signal module is present. if so replace valve adapter .
Tool Changer will Lock but not Unlock	Control/signal module safety features not met.	The tool stand Interlock, or other safety feature is preventing the Tool Changer from unlocking, refer to the control/signal module manual for more information. Control/signal module may not have bypass circuit and will have to be unlocked manually, refer to Section 5.1.1—Solenoid Valve Manual Override Procedure .

5.1.1 Solenoid Valve Manual Override Procedure

The manual override procedure should be used when the Tool Changer is locked without the Tool plate attached. The control module safety circuit does not allow the Tool Changer to be unlatched without the Tool plate attached and the tool in the tool stand.



WARNING: Do not use the solenoid valve manual override if the tool is locked to the Master. Using the manual override will release the Tool and may cause bodily injury or damage to equipment. If the Tool is attached to the Master, it must be secured in the tool stand or in a location where the tool weight is supported before using the manual override.



CAUTION: The manual override is not intended for normal operations. Manual override is to be used in situations where no alternative is available to unlock the Master. Do not execute the Latch command unless the Master and the Tool are ready to be coupled.

Tools required: 3 mm hex key, 2 mm ball end hex key

1. Using a 3 mm hex key, remove the M4 socket head cap screws, warning label, and nylon washer from the Unlock side of the solenoid valve. The Unlock side is marked with a “U”.



CAUTION: Applying excess force can damage the solenoid or cause the override button to stick in one position. Actuation of valve override buttons requires about 1 mm of travel and minimal of force. Use a non-sharp object, similar to ball nose 2 mm hex key, to gently depress the override button; an air release should be heard when the solenoid is activated.

2. Insert a 2 mm ball end hex key in the unlock valve screw hole and gently depress the valve override button. An air release should be heard when the solenoid is actuated. Make sure the locking mechanism is fully retracted.
3. Using a 3 mm hex key, replace the M4 socket head cap screws, warning label, and nylon washer and tighten the screw.

Figure 5.2—Manual Override

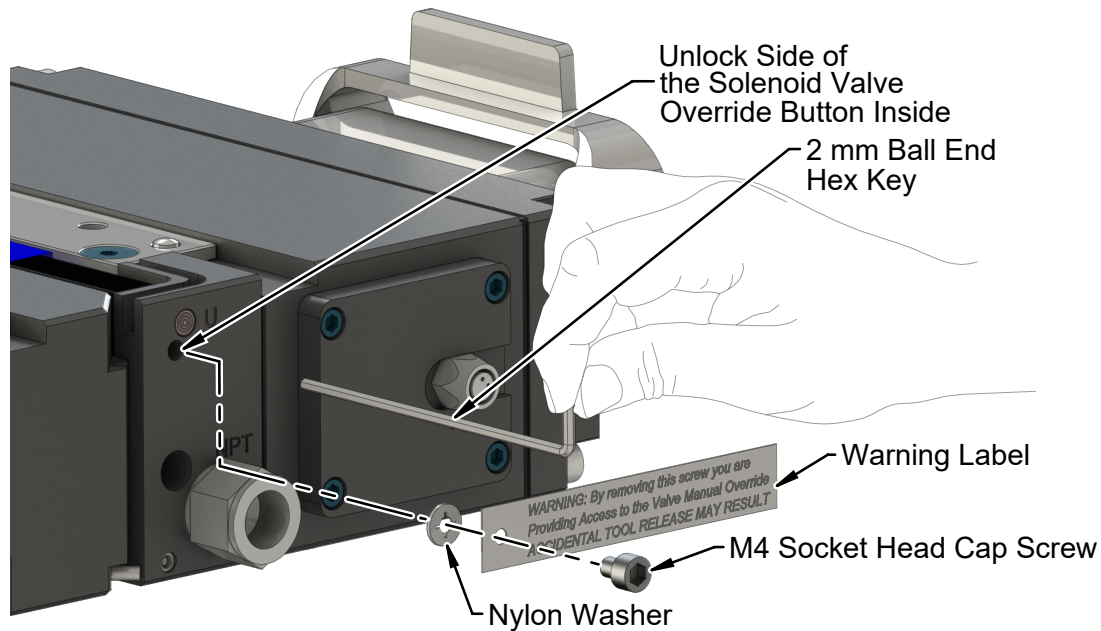

5.2 Service Procedures

The following service procedures provide instructions for inspection, adjustment, test or replacement of components.

5.2.1 Exhaust Muffler Replacement

The exhaust muffler allows air from the Tool Changer or Utility Coupler locking mechanism to be exhausted to the atmosphere, if the muffler is clogged it may affect the ability to Lock and Unlock the Tool Changer. Remove and check to make sure the Exhaust muffler is not clogged.

Parts required: Refer to [Section 8—Drawings](#).

Tools required: 11 mm Wrench

1. Place the Tool in a secure location.
2. Turn off and de-energize all energized circuits (for example: electrical, pneumatic, and hydraulic circuits).
3. Remove the exhaust muffler, blow through the muffler, if it is difficult to blow or you can not blow through it at all replace the exhaust muffler. Discard the exhaust muffler.
4. Thread the new exhaust muffler into the valve adapter housing. Tighten to contact plus one turn.
5. Safely resume normal operation.

Figure 5.3—Exhaust Muffler Replacement

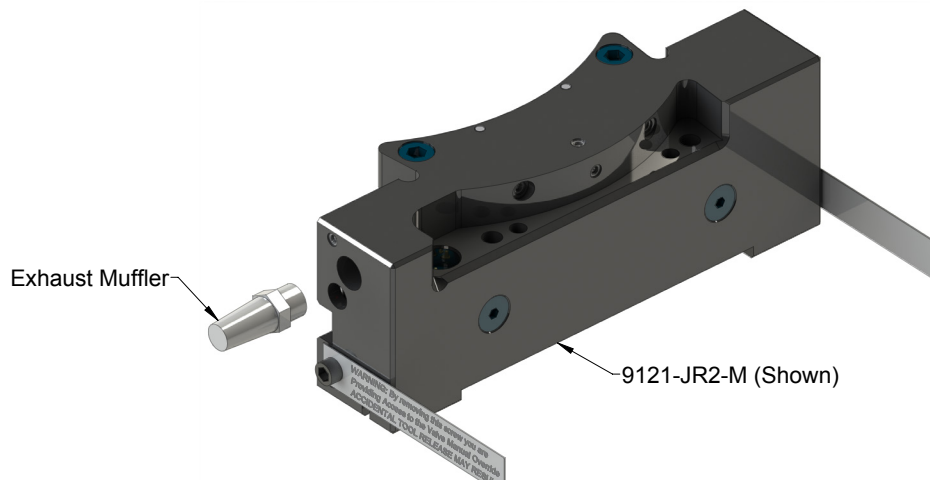

5.2.2 Inlet Filter Replacement

The inlet filter prevents particulates from entering the air supply to the Tool Changer or Utility Coupler locking mechanism. If the filter is clogged it may affect the ability to lock and unlock the Tool Changer. Check/replace the filter if there is a considerable reduction in unlocking speed.

Parts required: Refer to Drawings.

Supplies required: Loctite 569® or similar

Tools required: 5/8 mm hex wrench

1. Place the Tool in a secure location.
2. Uncouple the Master and Tool plates.
3. Turn off and de-energize all energized circuits (for example: electrical, pneumatic, and hydraulic circuits).
4. Disconnect the air supply to the filter.
5. Use a 5/8 hex wrench to remove the filter.
6. Replace clogged filter with new part:
 - a. Apply Loctite 569 to air supply port.
 - b. Use the wrench to thread the new filter into the valve adapter housing.
 - c. Tighten filter to 15 ft-lb.
7. Reconnect air supply to filter and tighten air supply line fitting. Torque should not exceed 15 ft-lb.
8. After the repair is complete, safely resume normal operation.

Figure 5.4— Filter Replacement

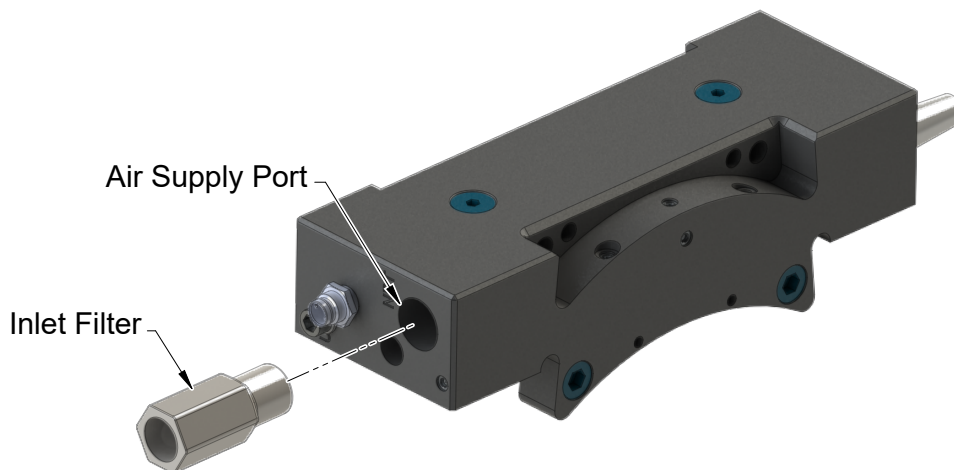

6. Serviceable Parts

6.1 Single Solenoid Valve Adapters with Valve Pass Through

Refer to [Section 8—Drawings](#) for serviceable parts for single solenoid valve adapters with valve pass through.

6.2 Tool Adapter Assembly

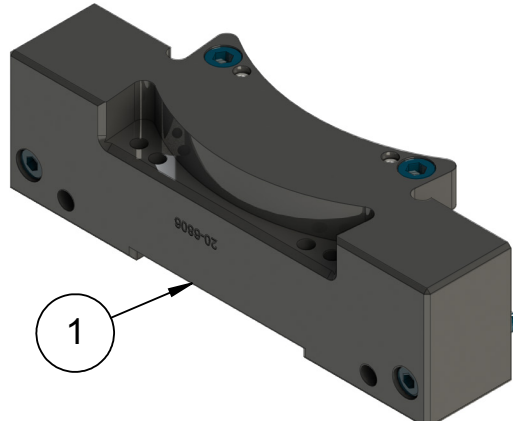

Table 5.2—Tool Adapter Assembly

Item No.	Qty	Part Number	Description
1	1	9005-20-1192	Tool Adapter Assembly
2	2	3500-1066016-15A	M6 x 16 mm Socket Head Cap Screw MB ND Microspheres
3	2	3500-1064035-15A	M5 x 35 mm Socket Head Cap Screw MB, ND Microspheres

7. Specifications

Table 5.3—Valve Adapter Specifications	
All Valve Adapter Models	All Valve Adapter with Single Solenoid and Valve Pass Through
Interface Connections	<u>Integrated Solenoid Valve Connector</u> : (3-Pin) Pin Block supporting Latch and Unlatch signals
Electrical Rating	19-29VDC operational voltage (Solenoid Valve)
Current Draw	Switched Power: 250mA @ 24VDC (Solenoid Valve) (only when locking or unlocking Tool Changer).
Air Pressure	60 - 100 psi (4.5 – 6.9 Bar) clean, dry, non-lubricated air
Air Filtration	40 microns
Environmental Resistance	Dust and water resistant, but not water proof or IP67 compliant
Solenoid Valves	Specification
Single Solenoid Valve	MAC Series 48, DC Voltage, 6W Coil, 250mA @ 19-29VDC
Operational Temperature Range	0 °F - 120 °F (-17.8 °C - 49 °C)
Cv	1.1
9121-JP7-M	Valve Adapter with Single Solenoid Rc and Valve Pass Through, QC-310, QC-313, QC-510, or QC-1210
Pneumatic Connection	Rc 1/4 (BSPT)
Weight	1.395 lbs (0.633 kg)
9121-JR2-M	Valve Adapter with Single Solenoid NPT and Valve Pass Through, QC-113, QC-210, QC-213, GL6L, or GL7L
Pneumatic Connection	1/4" NPT
Weight	1.255 lbs (0.57 kg)
9121-JR3-M	Valve Adapter with Single Solenoid NPT and Valve Pass Through, QC-310, QC-313, QC-510, or QC-1210
Pneumatic Connection	1/4" NPT
Weight	1.29 lbs (0.585 kg)

Table 5.4—Tool Adapter Assembly Specifications	
9005-20-1192	Tool Adapter Assembly, QC-210, QC-213, QC-310, QC-313, QC-510, QC-1210, GL6L, or GL7L
Weight	1.33 lbs (0.603 kg)

8. Drawings

Drawings are available on the [ATI website](#) or by contacting an ATI representative.