

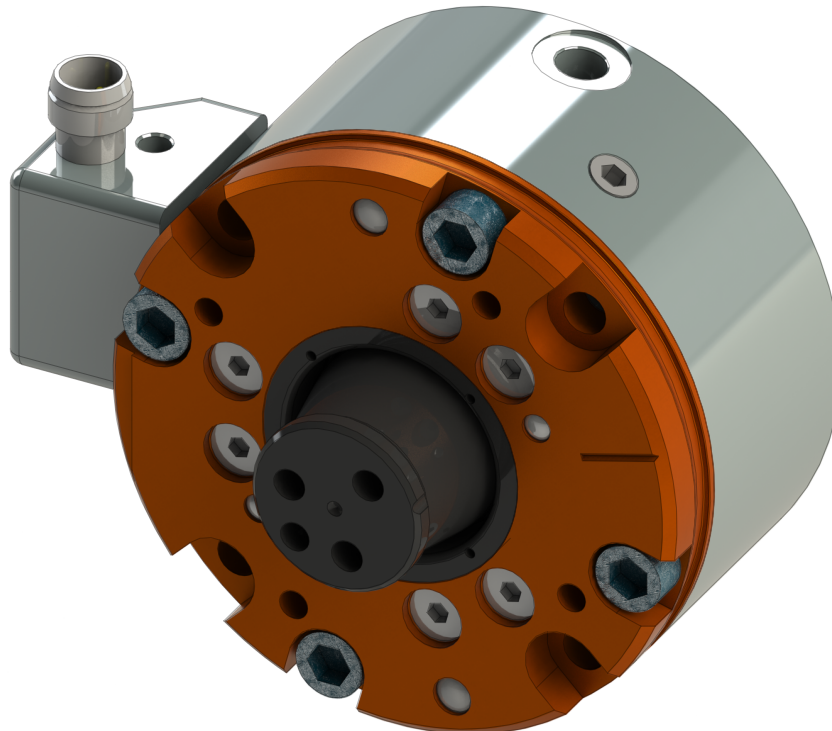

Robotic Collision Sensor SR-61 Manual

U.S. Patent Nos. 6069415 and 6690208



Document #: 9610-60-1006

Engineered Products for Robotic Productivity

Pinnacle Park • 1031 Goodworth Drive • Apex, NC 27539 USA • Tel: 919.772.0115 • Fax: 919.772.8259 • www.ati-ia.com

Forward



CAUTION: This manual describes the function, application and safety considerations of this product. This manual must be read and understood before any attempt is made to install or operate the product. Failure to read and understand the information in this manual may result in damage to equipment or injury to personnel.

Information contained in this document is the property of ATI Industrial Automation, Inc (ATI) and shall not be reproduced in whole or in part without prior written approval of ATI. The information herein is subject to change without notice. This manual is periodically revised to reflect and incorporate changes made to the product.

The information contained herein is confidential and reserved exclusively for the customers and authorized agents of ATI Industrial Automation and may not be divulged to any third party without prior written consent from ATI. No warranty including implied warranties is made with regard to accuracy of this document or fitness of this device for a particular application. ATI Industrial Automation shall not be liable for any errors contained in this document or for any incidental or consequential damages caused thereby. ATI Industrial Automation also reserves the right to make changes to this manual at any time without prior notice.

ATI assumes no responsibility for any errors or omissions in this document. Users' critical evaluation of this document is welcomed

©Copyright 2022 by ATI Industrial Automation. All rights reserved.

How to Reach Us

Sale, Service and Information about ATI products:

ATI Industrial Automation

1031 Goodworth Drive
Apex, NC 27539 USA
www.ati-ia.com

Tel: 919.772.0115

Fax: 919.772.8259

Application Engineering

Tel: 919.772.0115

Fax: 919.772.8259

E-mail: applicationsengineers@ati-ia.com

Table of Contents

Forward	2
Glossary	5
1. Safety	6
1.1 Explanation of Notifications.....	6
1.2 General Safety Guidelines.....	6
1.3 Safety Precautions	7
2. Product Overview	8
2.1 Product Description	8
3. Installation	9
3.1 Mechanical Installation	9
3.1.1 Fastener Torque Specifications	9
3.2 Electrical Connection.....	10
3.2.1 Test Switch Functionality	11
3.3 Pneumatic Connection	11
3.3.1 Operating Requirements	11
3.3.2 Calculating Estimated Pressure Setting	11
3.3.2.1 Calculate Applied Loads	11
3.3.2.2 Obtain Required Pressure Setting	13
3.3.3 Determining Exact Pressure Required	14
4. Operation	15
5. Maintenance	16
5.1 Periodic Lubrication Instructions.....	16
5.1.1 Cover Plate and Stem Disassembly.....	16
5.1.2 Cover Plate and Stem Cleaning and Lubrication	17
5.1.3 Cover Plate and Stem Re-assembly	18
6. Troubleshooting	19
6.1 Cable Replacement	20
6.2 Spring Conversion	21
6.3 Seal Replacement.....	22
6.4 IP65 Boot Replacement	23
6.5 Weld Splatter Shield Replacement	24
6.6 Flexible Boot Replacement	25
7. Specifications	26
8. Serviceable Parts	26
8.1 SR-61 with C5 Boot	26

9. Drawings	27
9.1 SR-61 Collision Sensor with Original Style Switch	27
9.2 SR-61 Collision Sensor with Current Style Switch	28
10. Terms and Conditions of Sale	30
6.1 Cable Replacement	20
6.2 Spring Conversion	21
6.3 Seal Replacement	22
6.4 IP65 Boot Replacement	23
6.5 Weld Splatter Shield Replacement	24
6.6 Flexible Boot Replacement	25
7. Specifications	26
8. Serviceable Parts	26
8.1 SR-61 with C5 Boot	26
9. Drawings	27
9.1 SR-61 Collision Sensor with Original Style Switch	27
9.2 SR-61 Collision Sensor with Current Style Switch	28
10. Terms and Conditions of Sale	30

Glossary

Term	Definition
Body	Cylindrical aluminum housing and air pressure chamber. An interface plate to the user's robot is usually attached here.
Cam	A hardened steel ring mounted inside the cover on which the hardened steel ball segments mounted to the stem are nested.
Collision Sensing Switch	A switch that changes state to an open circuit when a crash is detected. It is mounted in a threaded hole in the side of the body under the connector block. It is a normally open, PNP or NPN metal sensing proximity switch. It appears closed in the working (reset) position since it is sensing a steel target. The steel target moves out of range in the event of a crash.
Collision	The accidental impact between the end of arm tooling and some obstruction in its path.
Cover Plate	Disk-shaped aluminum cover for Collision Sensor body.
Crash	The result of a disturbance that displaces the Collision Sensor components from their standard, working position.
Interface Plate	Optional component used to adapt the Collision Sensor body or stem to the user's robot or tooling.
Piston	The component which, together with the Body, creates a pressure chamber. Varying the pressure in this chamber varies the load required to move the piston.
Reset	The ability of the Collision Sensor to return to its working position when a disturbing force or displacement is removed.
Stem	Round tapered post containing tapped holes and a dowel pin hole. An interface plate to the user's tooling is usually attached here.
Switch Target	A steel block mounted on top of the piston, the position of which is sensed by the Collision Sensing switch.

1. Safety

The safety section describes general safety guidelines to be followed with this product, explanation of the notifications found in this manual, and safety precautions that apply to the product. More specific notifications are imbedded within the sections of the manual were they apply.

1.1 Explanation of Notifications

The notifications included here are specific to the product(s) covered by this manual. It is expected that the user heed all notifications from the robot manufacturer and/or the manufacturers of other components used in the installation.



DANGER: Notification of information or instructions that if not followed will result in death or serious injury. The notification provides information about the nature of the hazardous situation, the consequences of not avoiding the hazard, and the method for avoiding the situation.



WARNING: Notification of information or instructions that if not followed could result in death or serious injury. The notification provides information about the nature of the hazardous situation, the consequences of not avoiding the hazard, and the method for avoiding the situation.



CAUTION: Notification of information or instructions that if not followed could result in moderate injury or will cause damage to equipment. The notification provides information about the nature of the hazardous situation, the consequences of not avoiding the hazard, and the method for avoiding the situation.

NOTICE: Notification of specific information or instructions about maintenance, operation, installation, or setup of the product that if not followed could result in damage to equipment. The notification can emphasize specific grease types, good operating practices, or maintenance tips.

1.2 General Safety Guidelines

The Collision Sensor is not designed for, nor should it be used in, situations involving the safety of humans or animals. The Collision Sensor is designed as a safety device to protect industrial components and machinery from damage resulting from collisions and impacts. In all situations the user is responsible for insuring that applicable safety practices are followed as outlined by the manufacturer of the equipment on which the Collision Sensor is used.

The routing of electrical and pneumatic lines must minimize the possibility of stress, pullout, kinking, rupture, etc. Failure of critical electrical and/or pneumatic lines to function properly may result in injury to personnel and damage to equipment.



CAUTION: The customer should lock out and discharge all energy to the work cell prior to working on any Collision Sensor system. Failure to do so may result in damage to equipment or injury to personnel.

1.3 Safety Precautions



WARNING: Do not perform maintenance or repair on the Collision Sensor with air pressure applied, current supplied to the sensor, or the robot not in a safe condition. Injury or equipment damage can occur if this is not observed. Always ensure that air pressure has been vented from the unit, that electrical current is not supplied to the Collision Sensor's signal circuit, and that the robot is in a safe, locked-out condition consistent with local and national safety standards before performing maintenance or repair on the Collision Sensor.



WARNING: The Collision Sensor is only to be used for intended applications and applications approved by the manufacturer. Using the Collision Sensor in applications other than intended will result in damage to Collision Sensor or end-of-arm tooling and could cause injury to personnel.



CAUTION: Do not adjust or remove either of the (2) set screws installed in the wall of the body. Doing so may result in damage to the unit or failure of the switch to operate. Refer to [Figure 5.5](#).

2. Product Overview

The Collision Sensor is a pneumatically-pressurized device offering protection to industrial robots and tooling in the event of accidental impacts and unanticipated loads. The Collision Sensor works by “breaking away” from its working geometry in the event of excessive torsional, moment, or compressive axial forces, or any combination of these. The Collision Sensor cannot respond to pure axial tension, which is an unlikely mode of loading. Removal of the upsetting force or moment allows the Collision Sensor to return to its normal working position.

As a collision occurs, internal motion of the Collision Sensor components cause a switch to change state to an open circuit. The switch circuit may be monitored by robotic controllers to stop operations before damage to the robot or tooling occurs. The load threshold at which the Collision Sensor breaks away is adjustable by controlling the air pressure supplied to the unit.

All Collision Sensor devices provide axial (compression only), torsional, and moment compliance.

2.1 Product Description

The Collision Sensor consists of a piston housing (body) closed with a cover plate assembly. A stem assembly protrudes through the cover plate assembly. The cover plate assembly incorporates a cam to accurately and repeatably position the stem assembly. The stem assembly is forced into position against the cam by a piston. The piston is supported by user supplied compressed air and an optional assist spring. The stem provides a mounting surface for customized interface plates. Tapped and through holes on the back surface of the body allow direct bolting of the body to the robot. All load-bearing components and those with wear surfaces are made of hard-coat anodized aluminum, hardened bearing steel, or hardened tool steel.

A collision sensing switch is positioned in the side of the body. A connector block assembly containing a 8 mm connector is mounted on the side of the Collision Sensor body. The user connects to the switch using the 8 mm connector for which a variety of cables are available. The user must also supply the Collision Sensor with dry, regulated, compressed air through a port on the side of the Collision Sensor body. The size and location of these connections are shown in the drawing provided at the end of this manual.

Figure 2.1—Collision Sensor Collision Sensor

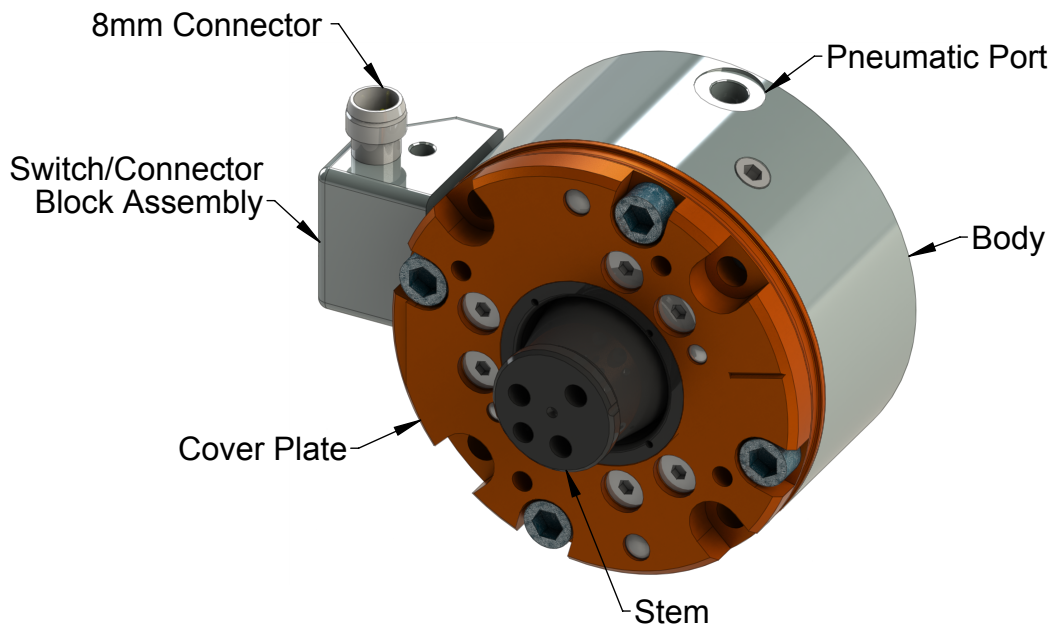

3. Installation

The Collision Sensor is commonly mounted with its body toward the robot and its stem toward the user tooling, however, this is strictly up to the user.

3.1 Mechanical Installation

The Collision Sensor can be mounted directly to the robot or to the user tooling using the dowel pin holes and the clearance / tapped holes in the Collision Sensor body. Should this not be possible, an interface plate must be fabricated.

A second interface plate is often required for mounting to the Collision Sensor stem. Such interface plates may be ordered from ATI as blank plates or machined as necessary for specific applications. Another option is for the user to fabricate their own interface plates.

NOTICE: The surface to which the Collision Sensor body is mounted must be flat and smooth and provide support for the entire surface of the body.

Once any required machining of the interface plates is complete, mount the Collision Sensor using hardware appropriately sized for the application. Connect an appropriately sized air line and fitting to the Collision Sensor.

NOTICE: Do not supply air pressure at this time.

All mounting hardware should be tightened. The use of an industrial thread-locking compound is recommended for all fasteners, refer to [Section 3.1.1—Fastener Torque Specifications](#).

Figure 3.1—Installation

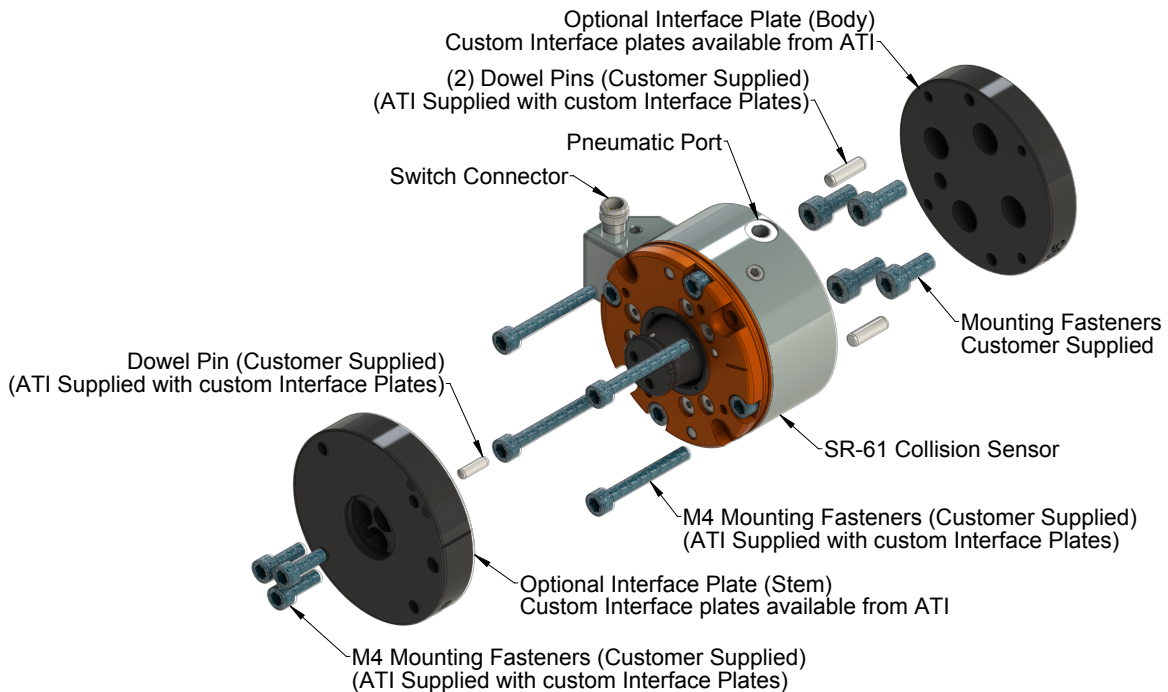

3.1.1 Fastener Torque Specifications

Table 3.1—Recommended Torques for ATI Supplied Fasteners		
Fastener Size	Torque	Recommended Thread Locker
M3-0.5 Cap Screw	19 in-lbs	Loctite 222 or equivalent
M4-0.7 Cap Screw	41 in-lbs	
M5-0.8 Cap Screw	85 in-lbs.	

3.2 Electrical Connection

The Collision Sensor is connected to the user's control wiring as a normally-open PNP or NPN proximity switch. The following sketch details the connections between the internal switch and the pins in the connector block assembly. Optional mating cables, available from ATI (refer to [Table 6.1](#)), utilize the brown-black-blue color code indicated.

 **CAUTION:** The user is responsible for connecting the collision sensor to their controls and providing an "electrical load" in series with the collision sensing switch. The switch is rated for instrument level signals of 100mA (max.) at 10–30VDC.

Figure 3.2—Switch Wiring

Standard PNP Switch

Switch Wiring:

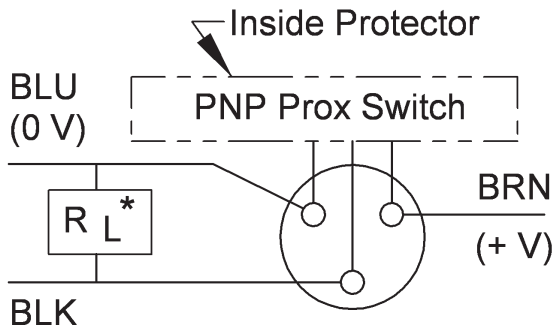

SWITCH RATING: 100mA (Max.)
at 10-30 VDC

* Provided by customer.

Switch Test Circuit:

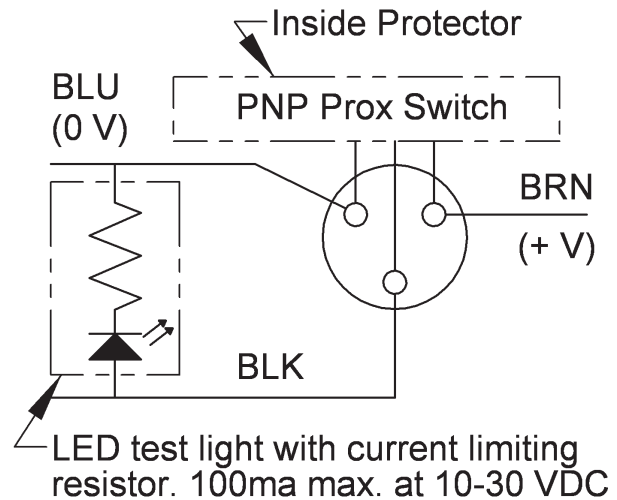

Optional NPN Switch

Switch Wiring:

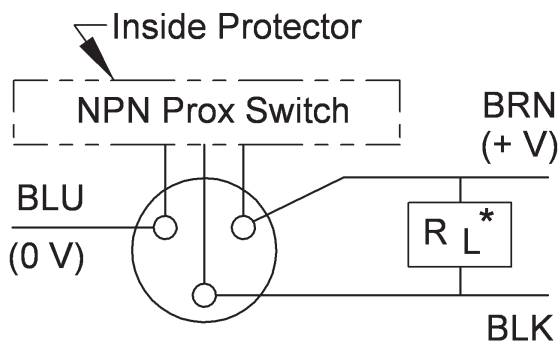

SWITCH RATING: 100mA (Max.)
at 10-30 VDC

* Provided by customer.

Switch Test Circuit:

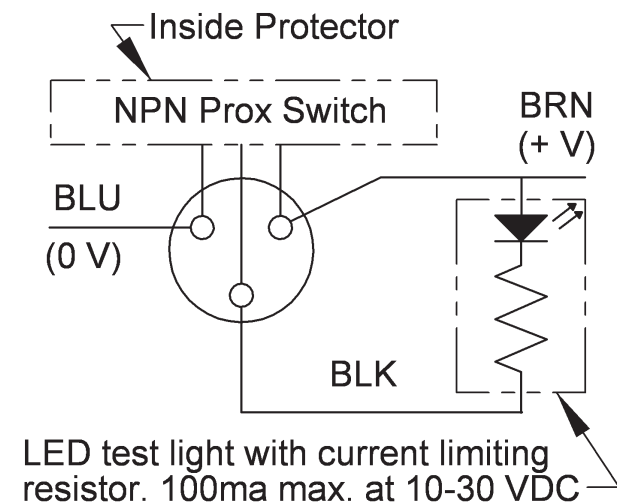

NOTE: Pin orientations are facing exterior of male receptacle in collision sensor.

3.2.1 Test Switch Functionality

Once the Collision Sensor has been installed and connected as described in the preceding paragraphs, proper electrical operation of the unit may be confirmed.

Supply the Collision Sensor with approximately 15 psi (1 bar) and ensure that the unit is electrically connected to the user's control circuit or to a test box per [Figure 3.2](#). The switch should appear closed.

Manually push the Collision Sensor to simulate a collision while observing the switch output. When the collision occurs the switch will open and the test light will turn off.

Release the Collision Sensor and it will return to its working position. The test light will illuminate.

3.3 Pneumatic Connection

Compressed air is to be supplied to the port marked "P" in the range of 20 psi to 90 psi. This port accepts #10-32 or M5 pneumatic fittings. The pressure setting required for a particular application can be estimated using the procedure outlined in [Section 3.3.2—Calculating Estimated Pressure Setting](#). The exact pressure required must be determined through testing using the procedure outlined in [Section 3.3.3—Determining Exact Pressure Required](#).

3.3.1 Operating Requirements

The Collision Sensor requires clean, dry, non-lubricated air delivered from a user-supplied, self-relieving regulator. The Collision Sensor is certified for accurate and repeatable operation when supplied with air at 20–90 psi (1.4–6.2 bar) of pressure operated in an environment with an ambient temperature range of 40–120°F (5–50°C). For connection to the user's controls, the Collision Sensor is equipped with a collision sensing switch. When the Collision Sensor is in the collision mode or the electrical cable to the switch is disconnected an open circuit is generated.

Proper sizing of the Collision Sensor is imperative for the safe and reliable operation of the unit. Contact ATI for assistance in selecting the proper unit.

Equivalent spring assist options of 5 psi (P05), 10 psi (P10), and 15 psi (P15) are available.



CAUTION: The level of the desired or required air pressure will vary according to the weight, loading, and motion of the user's tooling. Exercise caution while increasing the air pressure supplied to the Collision Sensor. When the pneumatically-supplied force is sufficient to re-seat the Collision Sensor the tooling will move to its working position.

3.3.2 Calculating Estimated Pressure Setting

In order to determine the proper pressure setting for the collision sensor one must consider all static and dynamic loads to which it is subjected. These include the loads produced due to the static weight of the tooling, the inertial loads imposed by robot motion and the loads produced by the end-effector when performing its intended tasks. Once these loads are calculated, the nominal pressure setting for the break-away point can be determined. The calculation proceeds as follows:

3.3.2.1 Calculate Applied Loads

[Figure 3.3](#) can be used to convert the forces acting on the end-effector tooling into the resulting moment, torque, and axial loads applied to the Collision Sensor. Use the diagram shown in [Figure 3.3](#) and the formulas below to calculate the worst-case applied loads for your application. All (3) load cases—axial, torque, and moment—should be assessed for their static, dynamic, and working force components.

NOTICE: Not all of the component forces (static, dynamic, and working) are present during all phases of the robot program. As a result, the worst case conditions for axial, torque, and moment loads may occur at different times in the program.

Figure 3.3—Collision Sensor Loading Diagram

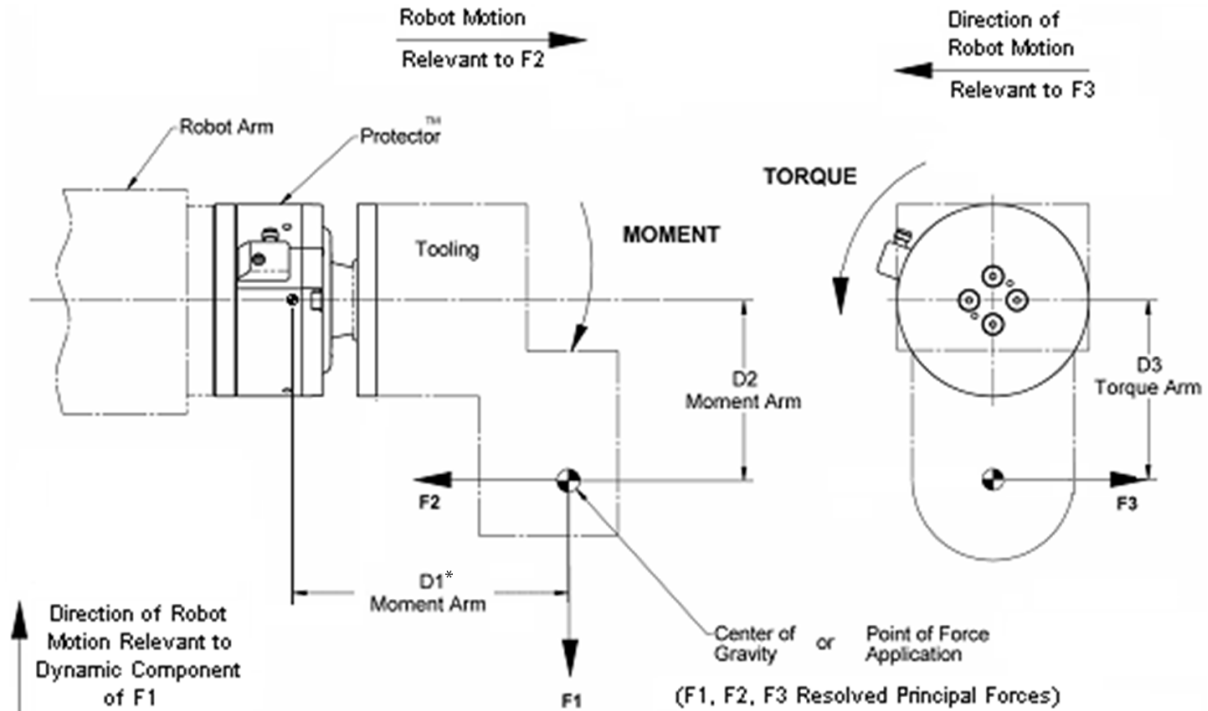

Formulas:

Axial Load (F) = F2

Torque (T) = F3*D3

Moment (M) = $\sqrt{(F1*D1)^2 + (F2*D2)^2}$

*D1 - Information needed to calculate found within 9230 drawing on ATI website.

NOTICE:

F1, F2, & F3 consist of the sum of their respective static, dynamic, and working force components; and should always be positive for purposes of calculating break-away pressure settings.

D1 should include the distance from the end of the stem to the internal pivot point on the collision sensor (.75" or 18.9 mm on an SR-61) and the thickness of the tooling side interface plate (.47" or 12 mm on an SR-61 with optional blank interface plate)

a. Static Force: The load applied by tooling weight while the robot arm is idle. This includes the weight of all parts attached to the Collision Sensor, acting at the assembly's center of gravity along the direction of gravity.

b. Dynamic Force: The inertial force imposed at the center of gravity of the tooling due to acceleration of the robot arm. This force acts in the direction opposite of motion. Dynamic forces are additive to static forces and must be carefully considered to ensure proper sizing of the Collision Sensor.

c. Working Force: Forces are generated at the tool-tip under normal working conditions. If these forces and their location are known, they can be converted into loads on the Collision Sensor using the same technique.

3.3.2.2 Obtain Required Pressure Setting

The pressure setting required can be approximated from the following formula:

$$P = P_m + P_t + P_f + P_mA + P_tA$$

Where **P_m**, **P_t**, and **P_f** are the pressure components related to the moment, torque, and force load components expected at the break-away. **P_mA** and **P_tA** are the dynamic versions of **P_m** and **P_t**. Dynamic forces from axial loading can usually be ignored since the robot is usually not accelerating in the axial direction. **P_m**, **P_t**, and **P_f** are calculated using the following formulas, where **M**, **T**, and **F** are the expected loads at the set pressure break-away:

English Units: lb-in, psi, lb

$$P_m = (M \times 0.376) - 3.3$$

$$P_t = (T \times 0.444) - 6.3$$

$$P_f = F \times 0.462$$

Metric Units: N-m, Bar, N

$$P_m = (M \times 0.2294) - 0.2$$

$$P_t = (T \times 0.2708) - 0.4$$

$$P_f = F \times 0.00719$$

P_mA and **P_tA** are calculated using the following formulas where **A** is the maximum acceleration in gravities (**G**'s):

English Units: lb-in, psi, G's

$$P_m = (M \times 0.376 \times A) - 3.3$$

$$P_t = (T \times 0.444 \times A) - 6.3$$

Metric Units: N-m, Bar, G's

$$P_m = (M \times 0.2294 \times A) - 0.2$$

$$P_t = (T \times 0.2708 \times A) - 0.4$$

Example: For an SR-61 with a static moment load of 50 lb-in, a static torque load of 30 lb-in, no axial load, and an acceleration of 2 **G**'s, the pressure setting is calculated as follows:

$$\begin{aligned} P &= [(50 \text{ lb-in} \times 0.376) - 3.3] + [(30 \text{ lb-in} \times 0.444) - 6.3] + [(50 \text{ lb-in} \times 0.376 \times 2\text{G's}) - 3.3] \\ &= 15.5 \text{ psi} + 7 \text{ psi} + 34.3 \text{ psi} \\ &= 56.8 \text{ psi} \end{aligned}$$

A nominal air pressure setting of 57 psi is required.

NOTICE:

If the calculated pressure required is above 90 psi do not install the unit. Contact ATI to determine the correctly sized collision sensor model for the application.

If the unit is equipped with P05 (5 psi equivalent), P10 (10 psi equivalent, or P15 (15 psi equivalent) preload spring, subtract this pressure to determine the actual pressure to be supplied.

3.3.3 Determining Exact Pressure Required

1. Set the pressure approximately 5 psi (0.3 Bar) higher than the pressure calculated in [Section 3.3.2—Calculating Estimated Pressure Setting](#).
2. Run the robot through a fully loaded cycle.
3. Watch for crash signals.

If the collision sensor does not generate a crash signal (open circuit) slightly reduce the pressure until a crash signal is generated and then increase the pressure slightly until the unit runs without false crash signals.

If the collision sensor does generate a crash signal increase the pressure slightly until the unit runs without false crash signals.

NOTICE: If the pressure required is above 90 psi remove the unit from service and contact ATI to determine the correctly sized collision sensor model for this application.



CAUTION: Use of pressures in excess of 90 psi can result in excessive damage to the unit in the event of a crash and voids the warranty.

4. Operation

With the Collision Sensor mounted and connected pneumatically and electrically the unit may be placed into operation. If possible, for safety and convenience, position the Collision Sensor and the tooling vertically so that the load is suspended below the Collision Sensor. Apply low-pressure air (2–15psi, 0.15–1bar) to the unit. Gradually increase the air pressure until the desired working pressure is applied.

In operation, the Collision Sensor should be supplied with the minimum air pressure necessary to allow continuous, uninterrupted operation of the unit. Nuisance collision detections caused by high accelerations and unanticipated loads will occur if the air pressure is too low. The magnitude of overhung loads, robot accelerations, and applied loads prevent ATI from recommending air pressure settings. Where high robot accelerations are anticipated the user may wish to supply the Collision Sensor with electronically variable or multiple, switchable air supplies. Alternatively, where working loads are small the Collision Sensor may be outfitted with auxiliary springs and supplied with high-pressure air only during robot moves. Using these techniques, the Collision Sensor may be supplied with higher air pressure when higher loads or accelerations are anticipated.

5. Maintenance



WARNING: Do not perform maintenance or repair on the Collision Sensor with air pressure applied, current supplied to the sensor, or the robot in an unsafe condition. Injury or equipment damage can occur if this is not observed. Always ensure that air pressure has been vented from the unit, that electrical current is not supplied to the Collision Sensor's signal circuit, and that the robot is in a safe, locked-out condition consistent with local and national safety standards before performing maintenance or repair on the Collision Sensor.

The Collision Sensor is a reliable device fabricated using heavy-duty components. In normal operation the unit requires no maintenance if proper air quality and pressures are maintained. Service kits are available in the event that the 8 mm connector or collision sensing switch becomes damaged.

Proper collision sensing should be verified on a regular basis. This can be scheduled twice a year or as a part of any robot or work cell preventive maintenance activities.

In applications where a high number of collisions occur on a regular basis, the life of the Collision Sensor can be extended with periodic maintenance. Partial disassembly allows the unit to be cleaned, re-greased, and reassembled without special tools or adjustment procedures. Such maintenance work should be conducted every 5,000 or fewer collisions.

5.1 Periodic Lubrication Instructions

5.1.1 Cover Plate and Stem Disassembly

Note: Cleaning may be accomplished with a clean, dry rag. For more thorough cleaning, use isopropyl alcohol.

1. Remove the (4) socket head cap screws securing the cover plate assembly to the body using an M3 hex key (refer to [Figure 5.11](#)).



CAUTION: Do not attempt to pry or wedge the cover plate assembly and body apart. Doing so can damage the mating surfaces and may render the parts unusable.

2. Remove the cover plate assembly by carefully pulling it straight up and off of the body. This may be difficult due to the close fit of the dowel pins used to align the parts. It may be necessary to hold the unit up by the cover plate and lightly tap on the stem with a rubber or plastic mallet.
Note: The dowel pins are pressed into the cover plate and are a slip fit into the body.



CAUTION: The cover plate assemblies and stem assemblies are factory-assembled as matched parts. Do not allow either of these assemblies to be mixed with those from other units.

Figure 5.1—Disassembly of Cover Plate

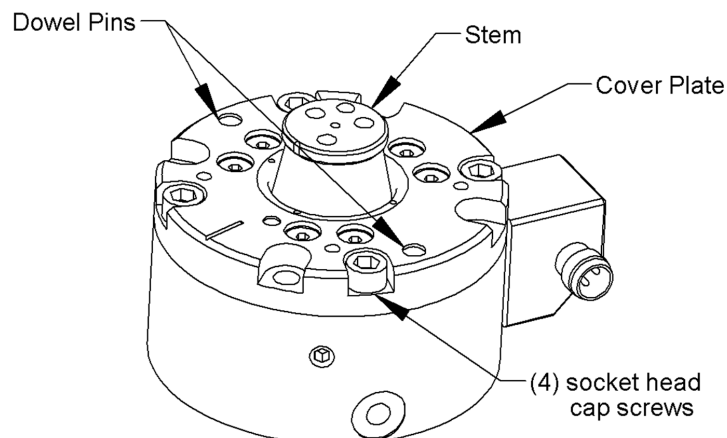

5.1.2 Cover Plate and Stem Cleaning and Lubrication

1. Clean the lubricant from the working surfaces of the cam and the clearance ring. Set the cover plate assembly aside for later re-use (refer to [Figure 5.22](#)).
2. Remove the stem assembly and clean the lubricant from the working surfaces of the ball segments and the stem. Set the stem assembly aside for later re-use (refer to [Figure 5.33](#)).
3. Clean the lubricant from the top surface of the piston (refer to [Figure 5.44](#)).

Figure 5.2—Cleaning and Re-lubricating the Cover Plate Assembly

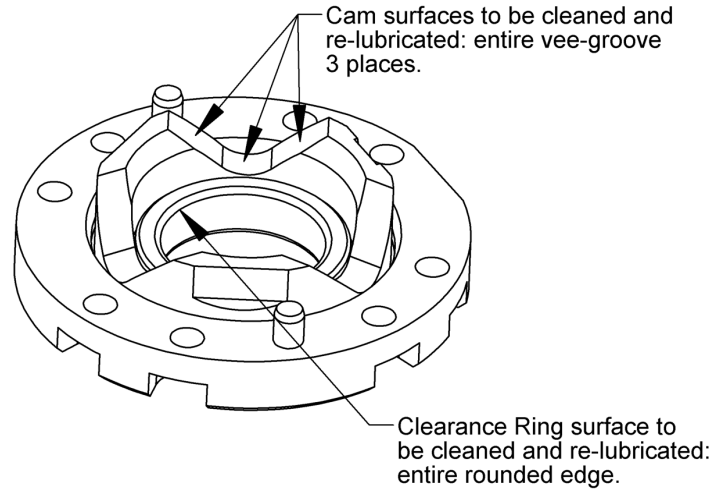

Figure 5.3—Cleaning and Re-lubricating the Stem

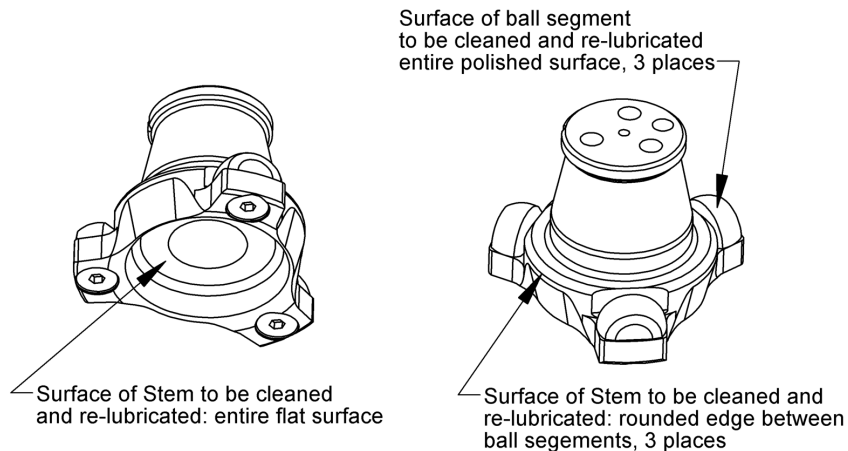
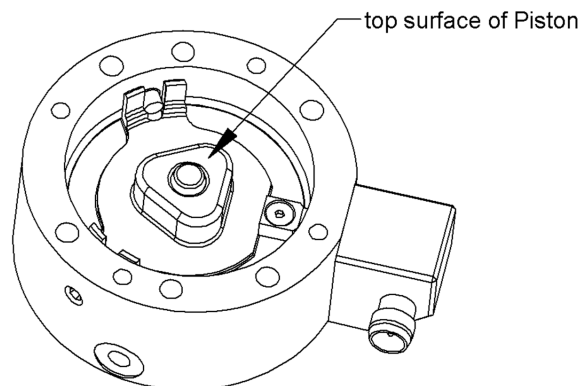

Figure 5.4—Cleaning and Re-lubricating Top Surface of Piston



5.1.3 Cover Plate and Stem Re-assembly

1. Apply a generous coating of CRC Extreme Pressure Moly C.V. Joint Grease (Moly Grease) to the top surface of the piston (refer to [Figure 5.44](#)).
2. Apply a generous coat of moly grease to each of the (3) ball segments on the stem assembly and to the rounded edge of the shoulders between the ball segments. Apply a layer of moly grease to the flat underneath surface of the stem (refer to [Figure 5.33](#)).
3. Apply a generous coat of moly grease to each of the (3) v-grooves in the cam and to the rounded edge of the clearance ring (refer to [Figure 5.22](#)).
4. With the stem assembly upright, set the cover plate assembly onto it. Make certain that the alignment grooves are lined up (refer to [Figure 5.55](#)).
5. Place the stem and cover plate together onto the body. Make certain that the alignment grooves in the plate and the stem are still lined up (refer to [Figure 5.55](#)).
6. Press the cover plate down onto the body.
7. Apply Loctite® 222MS to the (4) socket head cap screws and thread them into the body. Tighten the screws securely.

Figure 5.5—Cover Plate and Stem Alignment

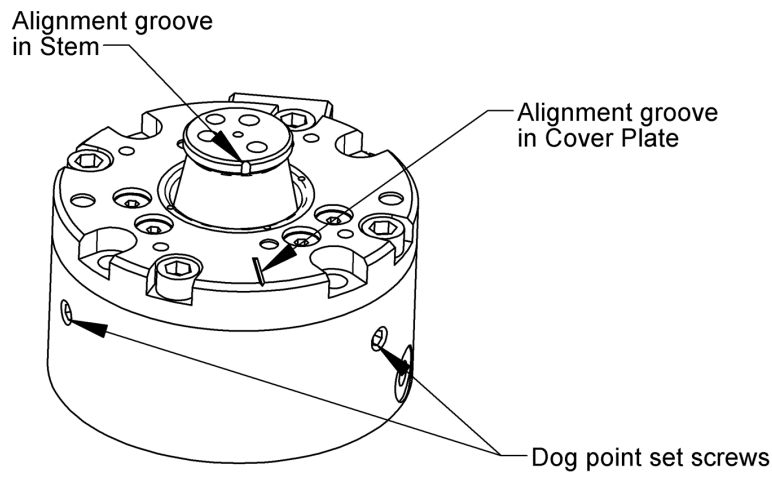

6. Troubleshooting

The Collision Sensor will offer exceptional performance in normal operation. However, the Collision Sensor is not a compliance device and frequent collisions should be avoided to maximize performance and life. The Collision Sensor is designed to automatically return to its working position once the disturbing force is removed. Should this fail to happen the following examinations should be performed to verify proper operation of the unit.

If the Collision Sensor still fails to reset or if the switch fails to close when the unloaded unit is in its working condition, contact ATI.

Symptom	Cause	Resolution
Unit fails to return to its working position	Mechanical obstruction preventing the Collision Sensor from free motion.	Ensure that there are no obstructions either on or around the tooling or the stem of the Collision Sensor. Pay particular attention to cables and tubing that may become trapped or snagged.
	Air supply insufficient or nonexistent.	Check the supply air pressure. Ensure that the supply air pressure is sufficient to support the loads placed upon the unit. Refer to Section 3.3.2—Calculating Estimated Pressure Setting for more information . If the supply pressure is too low the Collision Sensor will experience excessive nuisance collision sensing and fail to reset.
	O-ring or u-cup seals worn	Check to refer to if there is air pressure loss due to air escaping past O-ring or u-cup seals. Air leak may be detectable from air leaking past stem. If air is leaking replace seals, refer to Section 6.3—Seal Replacement .
	Improper cover and stem alignment from maintenance or repair	Check to refer to if the scribe lines on the Collision Sensor cover plate and stem are aligned or at a 120° off of alignment. If aligned or slightly misaligned refer to Internal component damage. If 120° out of alignment refer to Section 5.1.1—Cover Plate and Stem Disassembly and Section 5.1.3—Cover Plate and Stem Re-assembly to correct stem alignment.
	Internal component damage	Check to refer to if the scribe lines on the Collision Sensor cover plate and stem are aligned and the mounting surfaces of the body and stem must be parallel. If slightly misaligned or mounting surface is not parallel contact ATI.
Open circuit with unit reset	Control wiring damaged.	Disconnect the cable from the Collision Sensor and check the continuity of the cable. If damaged replace cable, refer to Section 6.1—Cable Replacement . If not damaged examine the system for logic problems.
	Switch is not functioning	Disconnect the cable from the Collision Sensor and use a test box connected per Figure 3.2 on the 8 mm connector to confirm that the switch is closed when the Collision Sensor is in the working position. If the switch is not closed replace, contact ATI.
Excessive force required to deflect stem	Regulator set at too high a pressure	Lower pressure setting.
	Regulator is not self-relieving.	Replace regulator with self-relieving regulator.
Optional Equipment		
Optional boot or EPDM seal leaking	Boot damaged	Inspect the boot for tears or damage replace if damaged. Refer to Section 6.4—IP65 Boot Replacement , or Section 6.5—Weld Splatter Shield Replacement or Section 6.6—Flexible Boot Replacement .

6.1 Cable Replacement

If the cable attached to your Collision Sensor becomes broken or worn, replacement cables may be purchased as follows:

Collision Sensor model number: 9610-061-Pxx-XX-x-x-x (x = any value).

Table 6.1—Cable Choices		
XX	Cable Number	Description
BN	---	No cable purchased with Collision Sensor – choose one of the following replacement cables
BB	8590-9909999-15	High-flex cable with straight screw-on connector, 5M (16.4 ft.) long with flying leads
BC	8590-9909999-06	High-flex cable with 90° snap-on connector, 5M (16.4 ft.) long with flying leads
BD	8590-9909999-89	High-flex cable with 90° screw-on connector, 10M (32.8 ft.) long with flying leads
BE	8590-9909999-116	High-flex cable with 90° screw-on connector, 5M (16.4 ft.) long with flying leads
BT	8590-9909999-48	High-flex cable with straight snap-on connector, 5M (16.4 ft.) long with flying leads
BU	8590-9909999-07	High-flex cable with straight snap-on connector, 10M (32.8 ft.) long with flying leads

6.2 Spring Conversion

The collision sensor may be equipped with an assist spring which provides a force equivalent to 5 psi (P05), 10 psi (P10) or 15 psi (P15) of applied pressure. An SR-61 may be field converted to add an assist spring or to contain a different range spring.

1. Remove cover plate assembly and stem assembly per [Section 5.1.1—Cover Plate and Stem Disassembly](#)
2. Remove the (2) M4 dog point setscrews using an M2.5 hex key (refer to [Figure 5.55](#)) (If unit is equipped with an assist spring, temporarily place the stem assembly on top of the piston and push down while removing the setscrews.)
3. Remove the stem assembly, piston assembly and assist spring (if present).
4. Place the new assist spring into the counter bore in the body.
5. Place the piston assembly in the body, orienting the notches in the ribs on the piston with the screw holes in the body and the switch target with the proximity switch (refer to [Figure 6.11](#)).
6. Temporarily place the stem assembly on top of the piston assembly.
7. Apply Loctite 222MS to the (2) M4 dog point setscrews.
8. Push the piston assembly down until its main surface is below the step in the body bore and hold in place (An arbor press may be used for this purpose.)
9. Screw the (2) M4 dog point setscrews clockwise until they touch the piston and then counterclockwise one turn.
10. Remove the stem assembly.
11. Replace the cover plate assembly and stem assembly per [Section 5.1.3—Cover Plate and Stem Re-assembly](#).

Figure 6.1—Piston Orientation

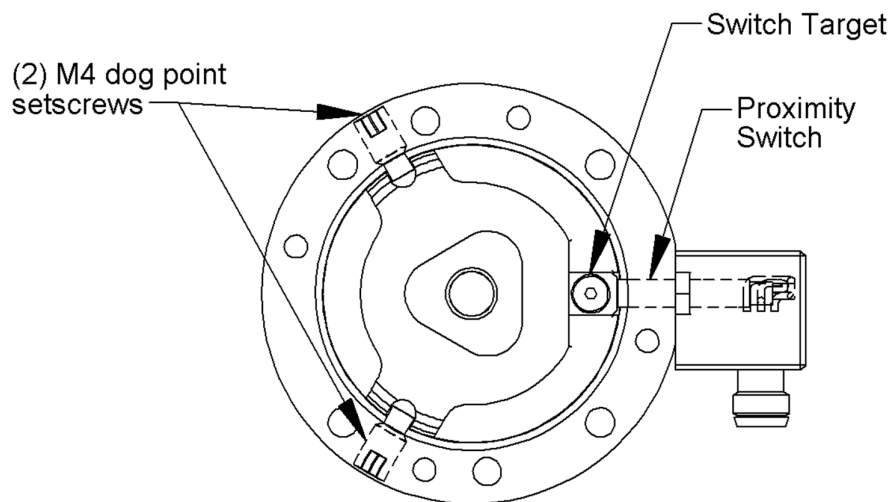

6.3 Seal Replacement

1. Disassemble cover assembly and stem assembly per [Section 5.1.1—Cover Plate and Stem Disassembly](#).
2. Remove the (2) M4 dog point setscrews using an M2.5 hex key (refer to [Figure 5.55](#)) (If unit is equipped with an assist spring, temporarily place the stem assembly on top of the piston and push down while removing the setscrews.)
3. Remove the stem assembly, piston assembly and assist spring (if present).
4. Remove and discard O-ring from groove on outside of piston.
5. Remove and discard u-cup from groove in center bore of piston.

Figure 6.2—U-cup Orientation

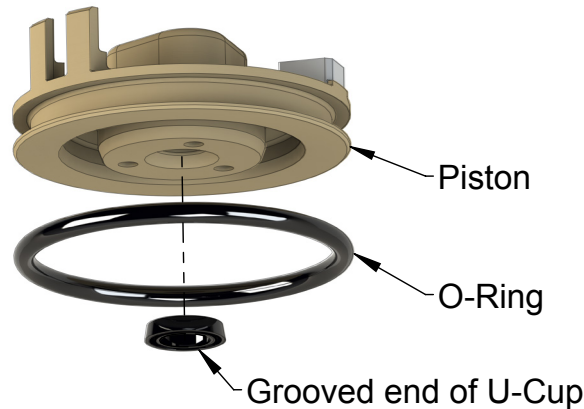

6. Apply Magnalube-G (Teflon/Petroleum base grease) to the new O-ring and u-cup.
7. Apply Magnalube-G to the body bore and post.
8. Assemble the new O-ring to the outer piston groove.
9. Assemble the new u-cup in the groove in the center bore of the piston making certain that the grooved end faces the plain round end of the piston (refer to [Figure 6.22](#)).
10. If equipped place the assist spring into the counter bore in the body.
11. Place the piston assembly in the body, orienting the notches in the ribs on the piston with the screw holes in the body and the switch target with the proximity switch (refer to [Figure 6.11](#)).
12. Temporarily place the stem assembly on top of the piston assembly.
13. Apply Loctite 222MS to the (2) M4 dog point setscrews.
14. Push the piston assembly down until its main surface is below the step in the body bore and hold in place (An arbor press may be used for this purpose.)
15. Screw the (2) M4 dog point setscrews clockwise until they touch the piston and then counterclockwise one turn.
16. Remove the stem assembly.
17. Re-assemble stem assembly and cover assembly per [Section 5.1.3—Cover Plate and Stem Re-assembly](#).

6.4 IP65 Boot Replacement

1. Remove (4) M3 x 6 flat head socket cap screw and shield retainer (refer to [Figure 6.33](#)).
2. Remove boot and discard.
3. Use a clean cloth soaked in isopropyl alcohol to remove gasket sealer from the stem and cover Plate.
4. Apply Permatex® Grade 2 gasket sealer to top of stem below flange and to center band of cover plate (refer to [Figure 6.33](#)).
5. Install new boot by stretching the center hole over the stem. Line up the screw holes and clearance slots with those in the cover plate.
6. Place the boot retainer on top of the boot. Line up the screw holes and clearance slots.
7. Apply Loctite 222MS to threads of (4) M3 x 6 flat head socket cap screw and install through boot retainer and boot into cover plate. Tighten until boot is slightly compressed.

Figure 6.3—IP65 Boot Replacement

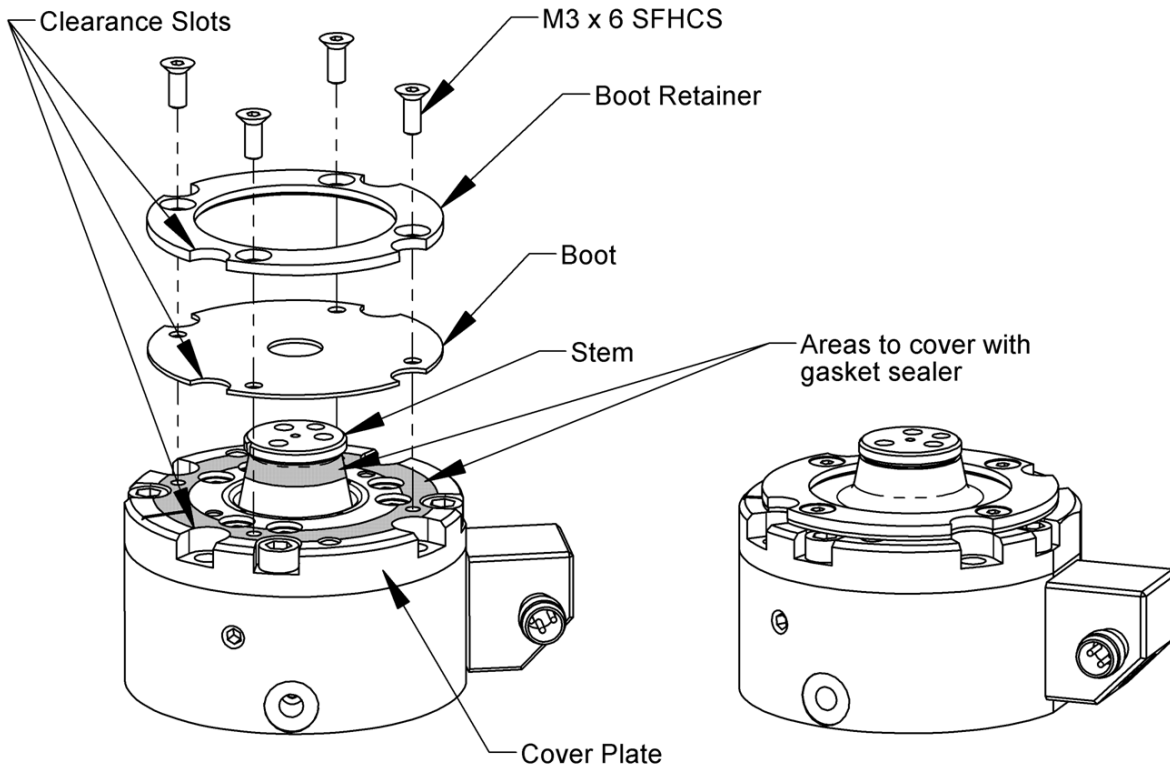

6.5 Weld Splatter Shield Replacement

1. Remove (4) M3 x 6 flat head socket cap screw and shield retainer (refer to [Figure 6.44](#)).
2. Remove weld shield and EPDM seal and discard.
3. Install new EPDM seal by stretching the center hole over the stem.
4. Place the new weld shield on top of the cover plate and partially covering the EPDM seal. Line up the screw holes and clearance slots.
5. Place the shield retainer on top of the weld shield. Line up the screw holes and clearance slots.
6. Apply Loctite 222MS to threads of (4) M3 x 6 flat head socket cap screw and install through shield retainer and weld shield into cover plate. Tighten until weld shield is slightly compressed.

Figure 6.4—Weld Splatter Shield Replacement

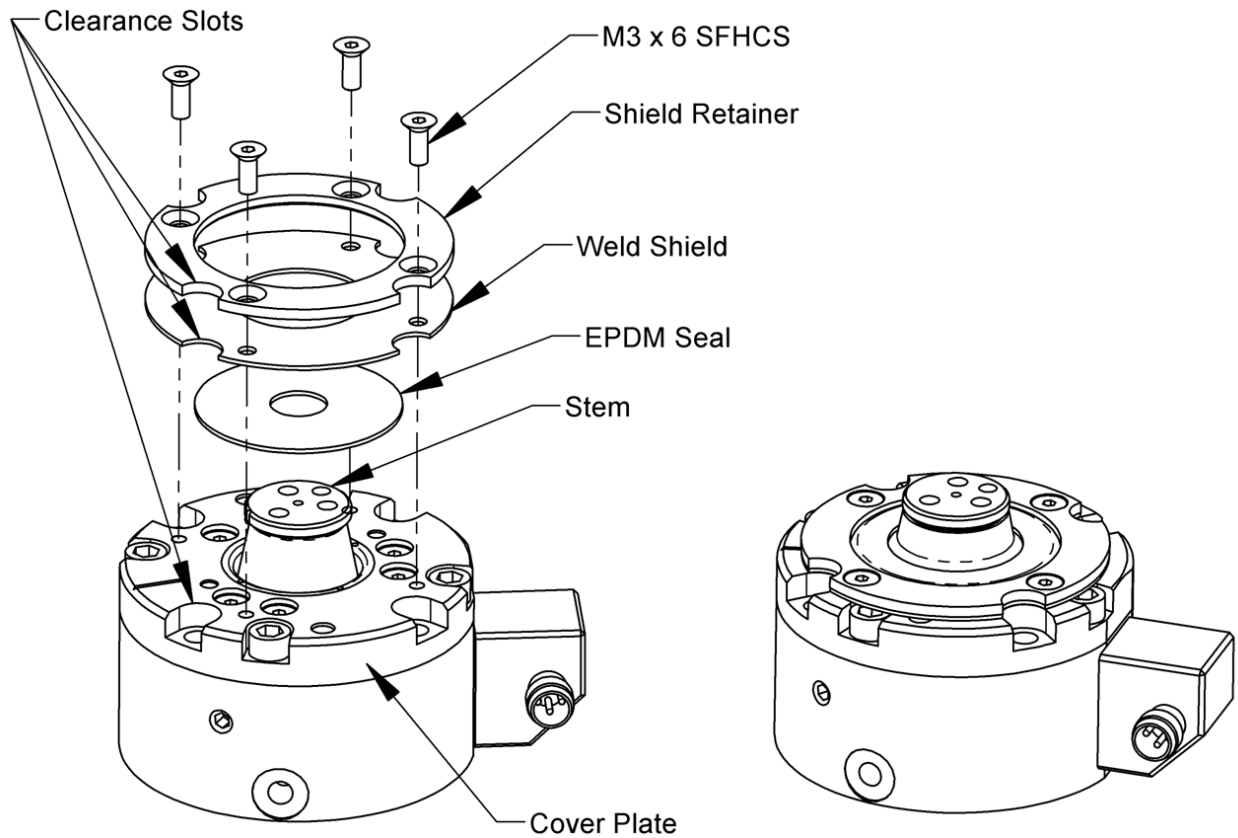

6.6 Flexible Boot Replacement

1. Remove the (2) garter springs retaining the flexible boot to the Collision Sensor body and the interface plate.(refer to [Figure 6.55](#)).
2. Remove the flexible boot and discard.
3. Install the new flexible boot by stretching over the Collision Sensor body and the interface plate.
4. Secure the flexible boot using the (2) garter springs, make sure the garter springs fit tightly in the groove in the Collision Sensor body and the interface plate.

Figure 6.5—Flexible Boot Replacement



7. Specifications

Figure 7.1—Specifications		
Displacement	Angular	+/- 11° max.
	Torsional	+/- 20° max.
	Axial	0.22 in (5.6 mm) max.
Load Limit	Moment	248 in-lbs (28 N-m)
	Axial	195 lb. (867 N)
	Torsional	216 in-lbs. (24 N-m)
Weight		0.70 lb. (0.58 Kg)
Operating	Pressure	(25-90 psi) (1.7-6.2bar)
	Temp.	40-120oF (5-50oC)
Connector Type Switch Rating		3-pin 8 mm connector 100mA 10-30VDC
Sensitivity		.02 in (.5 mm) axial
Spring Assist Option		5, 10,15 psi equivalents available

8. Serviceable Parts

There are (2) styles of switch/connector block assemblies for the SR-61 Collision Sensor. The original style serviceable parts are shown in [Section 9.1—SR-61 Collision Sensor with Original Style Switch](#). The current style serviceable parts are shown in [Section 9.2—SR-61 Collision Sensor with Current Style Switch](#). Some optional parts are provided in [Section 8.1—SR-61 with C5 Boot](#).

8.1 SR-61 with C5 Boot

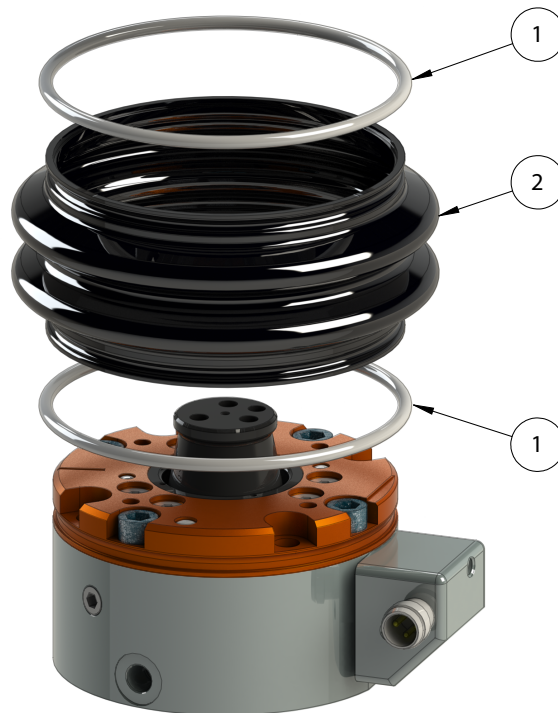

SR-61 with C5 Boot			
Item No.	Qty	Part Number	Description
1	2	3610-0368800-20	Garter Spring, SR-061 Boot
2	1	3700-60-1554	Flex Boot, SR-061

9. Drawings

9.1 SR-61 Collision Sensor with Original Style Switch

Rev.	Description	Initiator	Date
04	Eco 13429, updated to show new target switch.	LH	5/24/16

ITEM NO.	QTY	PART NUMBER	DESCRIPTION
1	4	3500-1062012-15A	M4 X12 SHCS Blue Dyed Magni-565, ND Microspheres
2	1	9160-STEMCOVKIT-061*	COVER PLATE, SUB-ASSEMBLY
3	1	NSS (INCLUDED IN ITEM 2)	STEM, SUB-ASSEMBLY
4	1	9005-60-1007	PISTON, SR-61
5	1	NSS (INCLUDED IN ITEM 4)	BODY, SR-61
6	1	3610-7601800-20	WAVE SPRING, P05
		3610-7602000-20	WAVE SPRING, P10
		3610-7601800-21	WAVE SPRING, P15
7	2	3500-1964010-15	M5 x 10 Dog Point Setscrew Black Oxide
8	1	9160-SENSOR-061**	Switch Assembly, SR-061
9	1	9160-SEAL-061	Seal, 0.38 O.D. x 0.25 I.D.
10	1	NSS (INCLUDED IN ITEM 9)	O-ring, 1.487 ID x .103W
11	1	9160-BOOT-061	Boot Retainer, SR-61
12	1	3700-60-1478	Boot, SR-061
13	1	9160-SHIELD-061	Weld Shield, SR-061
14	1	NSS (INCLUDED IN ITEM 13)	EPDM Seal, SR-61
15	4	NSS (INCLUDED IN ITEMS 11 AND 13)	M3 x 6mm SFHCS Metric Blue with Microspheres

NSS - NOT SOLD SEPERATELY
 * FOR UNITS WITH GREY COVERS ADD "-S" TO END OF KIT NUMBER.
 ** FOR UNITS WITH NPN SWITCHES (MODEL NUMBER ENDING IN "S1") ADD "-S1" TO END OF KIT NUMBER.

<p>NOTES: UNLESS OTHERWISE SPECIFIED, DO NOT SCALE DRAWING. ALL DIMENSIONS ARE IN MILLIMETERS.</p>	<p>1031 Goodworth Drive, Apex, NC 27539, USA Tel: 919.772.0115 Fax: 919.772.8259 Email: info@ati-ia.com www.atia.com ISO 9001 Registered Company</p>	<p>PROPERTY OF ATI INDUSTRIAL AUTOMATION, INC. NOT TO BE REPRODUCED IN ANY MANNER EXCEPT ON ORDER OR WITH PRIOR WRITTEN AUTHORIZATION OF ATI.</p>
<p>ATI INDUSTRIAL AUTOMATION</p>		<p>PROJECT #: 050310-1 SHEET 1 OF 1</p>
<p>DRAWN BY: D. Wagner 9/27/05 CHECKED BY: LH 11/2/05</p>		<p>TITLE: SR-61 Collision Sensor Assembly</p>
<p>SCALE: 3:4</p>		<p>DRAWING NUMBER: 9230-60-1085</p>
<p>30 ANGLE PROJECTION</p>		<p>REVISION: 04</p>

9.2 SR-61 Collision Sensor with Current Style Switch

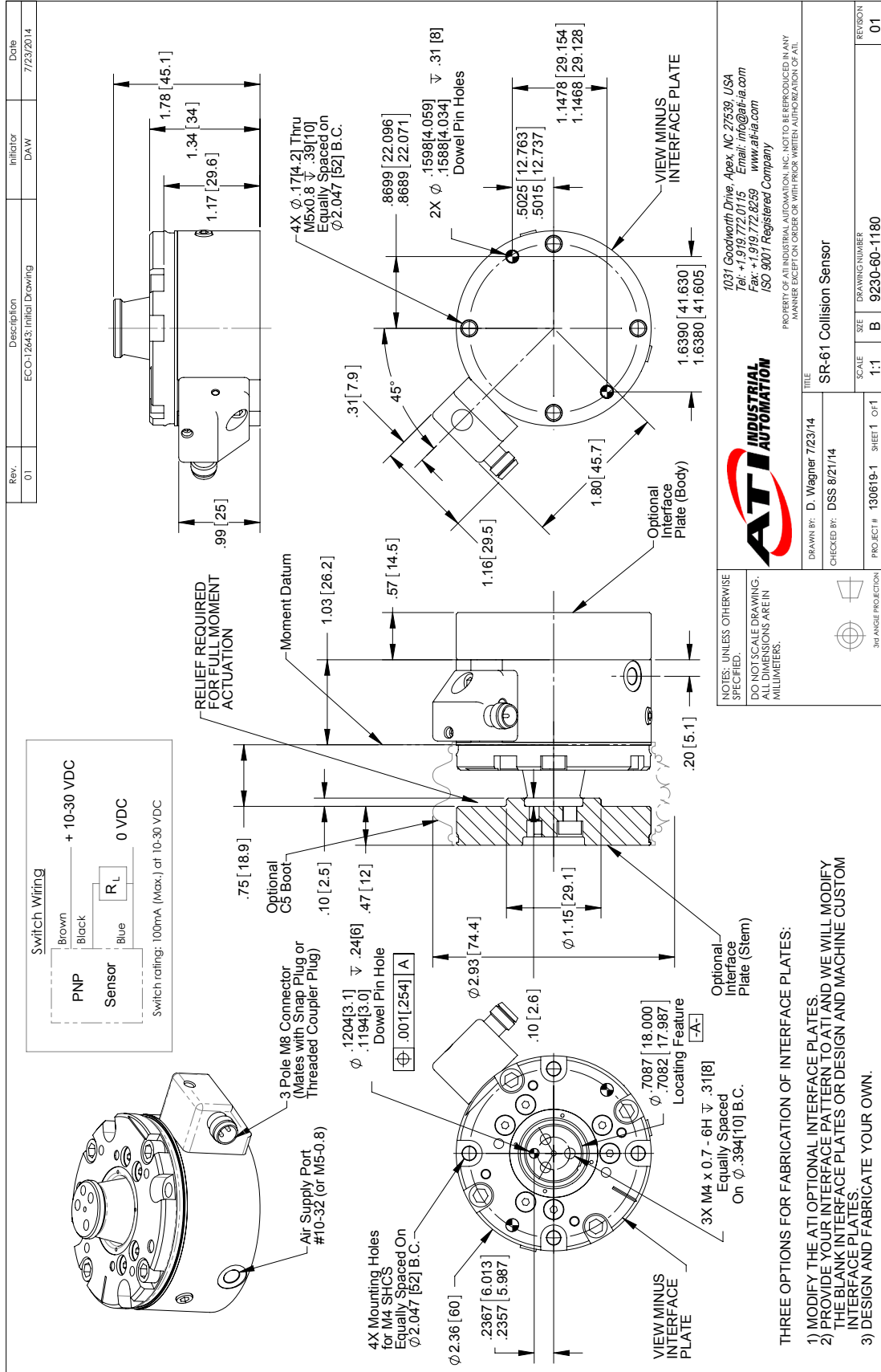

ITEM NO.	QTY	PART NUMBER	DESCRIPTION
1	4	3500-1062012-15A	M4 x12 SHCS, Blue Dyed Magni-565, ND Microspheres
2	1	9160-STEMCOVKIT-061 *	Cover Plate, Sub-Assembly
3	1	NSS (included in item 2)	Stem, Sub-Assembly
4	1	9005-60-1054	Piston, SR-61
5	1	NSS (included in item 4)	SR-061 Body (Improved Switch Version)
6	1	3610-7801800-20	Wave Spring, P05
7	2	3500-1964010-15	Wave Spring, P10
8	1	9160-SENSOR-061-2 **	Wave Spring, P15
9	1	9160-SEAL-061	M5 x 10 Dog Point Setscrew Black Oxide
10	1	NSS (included in item 9)	Switch Assembly, SR-061
11	1	3700-60-1477	Seal, 0.38 O.D. x 0.25 I.D.
12	1	3700-60-1478	O-ring, 1.487 ID x .103W
13	1	3700-60-1506	Boot Retainer, SR-61
14	1	3700-60-1507	Boot, SR-061
15	4	3500-1258006-21	Weld Shield, SR-061
			EPDM Seal, SR-61
			M3 x 6mm SFHCS Metric Blue with Microspheres

NSS - NOT SOLD SEPERATELY
 * FOR UNITS WITH GREY COVERS ADD "-S" TO END OF KIT NUMBER.
 ** FOR UNITS WITH NPN SWITCHES (MODEL NUMBER ENDING IN "S1") ADD "-S1" TO END OF KIT NUMBER.

Rev. 02 Description: Eco 13629; Updated to show new target switch. Initiator: LH Date: 5/24/16

1031 Goodworth Drive, Apex, NC 27539, USA
 Tel: +1 919 772 0115 Email: info@ati-ia.com
 Fax: +1 919 772 8259 www.ati-ia.com
 ISO 9001 Registered Company

ATI INDUSTRIAL AUTOMATION

PROPERTY OF ATI INDUSTRIAL AUTOMATION, INC. NOT TO BE REPRODUCED IN ANY MANNER EXCEPT BY ORDER OR WITH PRIOR WRITTEN AUTHORIZATION OF ATI.

PROJECT # 130619-1 SHEET 1 OF 1 SCALE 3:4 DRAWING NUMBER B 9230-60-1181 REVISION 02

NOTES: UNLESS OTHERWISE SPECIFIED, DO NOT SCALE DRAWING. ALL DIMENSIONS ARE IN MILLIMETERS.

3-ANGLE PROJECTION

TITLE: SR-61 Collision Sensor Assembly
 DRAWN BY: D. Wagner 7/23/14
 CHECKED BY: DSS 8/21/14

10. Terms and Conditions of Sale

The following Terms and Conditions are a supplement to and include a portion of ATI's Standard Terms and Conditions, which are on file at ATI and available upon request.

ATI warrants to Purchaser that Collision Sensor products purchased hereunder will be free from defects in material and workmanship under normal use for a period of one (1) year from the date of shipment. The warranty period for repairs made under a RMA shall be for the duration of the original warranty, or ninety (90) days from the date of repaired product shipment, whichever is longer. ATI will have no liability under this warranty unless: (a) ATI is given written notice of the claimed defect and a Description thereof within thirty (30) days after Purchaser discovers the defect and in any event not later than the last day of the warranty period; and (b) the defective item is received by ATI not later (10) days after the last day of the warranty period. ATI's entire liability and Purchaser's sole remedy under this warranty is limited to repair or replacement, at ATI's election, of the defective part or item or, at ATI's election, refund of the price paid for the item. The foregoing warranty does not apply to any defect or failure resulting from improper installation, operation, maintenance or repair by anyone other than ATI.

ATI will in no event be liable for incidental, consequential or special damages of any kind, even if ATI has been advised of the possibility of such damages. ATI's aggregate liability will in no event exceed the amount paid by purchaser for the item which is the subject of claim or dispute. ATI will have no liability of any kind for failure of any equipment or other items not supplied by ATI.

No action against ATI, regardless of form, arising out of or in any way connected with products or services supplied hereunder may be brought more than one (1) year after the cause of action occurred.

No representation or agreement varying or extending the warranty and limitation of remedy provisions contained herein is authorized by ATI, and may not be relied upon as having been authorized by ATI, unless in writing and signed by an executive officer of ATI.

Unless otherwise agreed in writing by ATI, all designs, drawings, data, inventions, software and other technology made or developed by ATI in the course of providing products and services hereunder, and all rights therein under any patent, copyright or other law protecting intellectual property, shall be and remain ATI's property. The sale of products or services hereunder does not convey any express or implied license under any patent, copyright or other intellectual property right owned or controlled by ATI, whether relating to the products sold or any other matter, except for the license expressly granted below.

In the course of supplying products and services hereunder, ATI may provide or disclose to Purchaser confidential and proprietary information of ATI relating to the design, operation or other aspects of ATI's products. As between ATI and Purchaser, ownership of such information, including without limitation any computer software provided to Purchaser by ATI, shall remain in ATI and such information is licensed to Purchaser only for Purchaser's use in operating the products supplied by ATI hereunder in Purchaser's internal business operations.

Without ATI's prior written permission, Purchaser will not use such information for any other purpose or provide or otherwise make such information available to any third party. Purchaser agrees to take all reasonable precautions to prevent any unauthorized use or disclosure of such information.

Purchaser will not be liable hereunder with respect to disclosure or use of information which: (a) is in the public domain when received from ATI; (b) is thereafter published or otherwise enters the public domain through no fault of Purchaser; (c) is in Purchaser's possession prior to receipt from ATI; (d) is lawfully obtained by Purchaser from a third party entitled to disclose it; or (f) is required to be disclosed by judicial order or other governmental authority, provided that, with respect to such required disclosures, Purchaser gives ATI prior notice thereof and uses all legally available means to maintain the confidentiality of such information.