



**ATI Single Axis
Radially Compliant
Robotic RCT-151
(Model 9150-RCT-151)**

Product Manual

US Patent # 6,974,286 B2; #7,396,197 B2

UK Patent # GB2,418,631 B

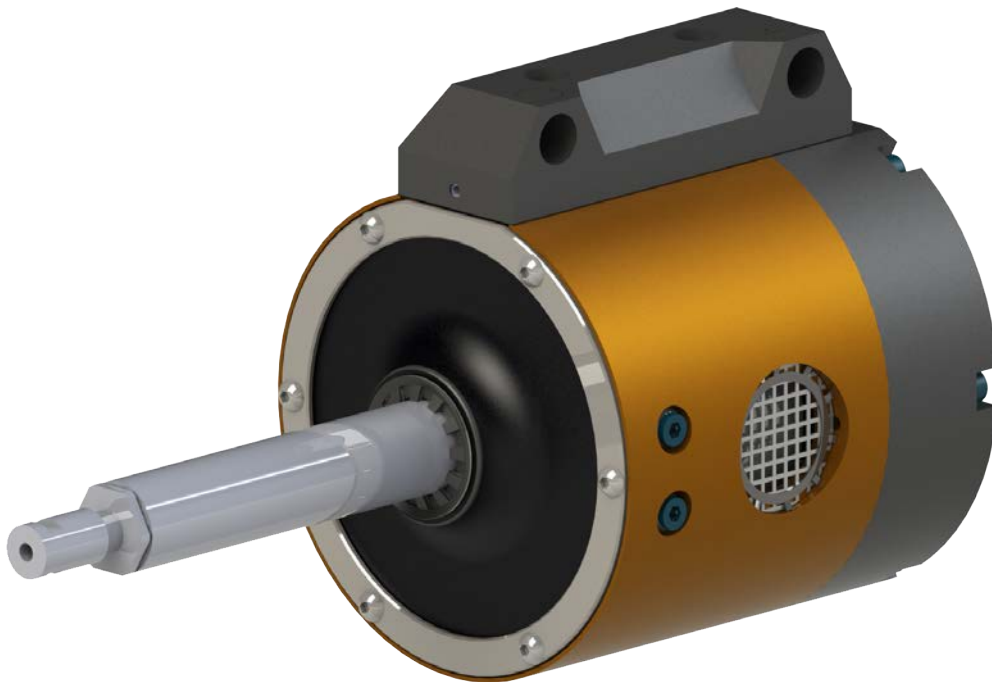

Document #: 9610-50-1041

Foreword



CAUTION: This manual describes the function, application, and safety considerations of this product. This manual must be read and understood before any attempt is made to install or operate the product, otherwise damage to the product or unsafe conditions may occur.

Information contained in this document is the property of ATI Industrial Automation, Inc (ATI) and shall not be reproduced in whole or in part without prior written approval of ATI. The information herein is subject to change without notice. This manual is periodically revised to reflect and incorporate changes made to the product.

The information contained herein is confidential and reserved exclusively for the customers and authorized agents of ATI Industrial Automation and may not be divulged to any third party without prior written consent from ATI. No warranty including implied warranties is made with regard to accuracy of this document or fitness of this device for a particular application. ATI Industrial Automation shall not be liable for any errors contained in this document or for any incidental or consequential damages caused thereby. ATI Industrial Automation also reserves the right to make changes to this manual at any time without prior notice.

ATI assumes no responsibility for any errors or omissions in this document.

Copyright © (2023) by ATI Industrial Automation. All rights reserved.

How to reach us:

Sale, Service and Information about ATI products:

ATI Industrial Automation

1031 Goodworth Drive
Apex, NC 27539 USA
www.ati-ia.com
Tel: +1 919-772-0115
Fax: +1 919-772-8259

Application Engineering

Tel: +1 919-772-0115
Fax: +1 919-772-8259
E-mail: ATI-MRapplications@novanta.com
24/7 Support: +1 855 ATI-IA 00 (+1 855-284-4200)

Table of Contents

Foreword	2
Glossary	5
1. Safety.....	6
1.1 Explanation of Notifications.....	6
1.2 General Safety Guidelines.....	6
1.3 Safety Precautions	7
2. Product Overview	8
2.1 Tool Collet Systems	8
2.2 Technical Description	9
2.2.1 Environmental Limitations	9
2.2.1.1 Operation	9
2.2.1.2 Storage	9
2.2.2 Compliance Unit Performance	10
3. Installation	11
3.1 Transportation and Protection during Transportation.....	11
3.2 Inspection of Condition When Delivered	11
3.3 Unpacking and Handling	11
3.4 Storage and Preventive Maintenance during Storage.....	11
3.5 Side Mounting Installation.....	12
3.6 Axial Mounting Installation.....	13
3.7 Pneumatics	14
4. Operation	16
4.1 Safety Precautions.....	16
4.2 Normal Operation	17
4.2.1 Air Quality.....	17
4.2.2 No Lubrication	17
4.2.3 Bur Selection, Design, and Maintenance	17
4.2.4 RCT-151 Approach Path Should be Slow and at an Angle	17
4.2.5 No Axial Loading	17
4.2.6 Perpendicular Loading while Locked to Single Axis	17
4.3 RCT-151 Working Environment.....	18
4.4 Tool Center Point (TCP) Position and Programming	18
4.5 Cutter Operation and Bur Selection	19
4.5.1 Bur Selection.....	20
4.6 Locking the Tool to Single Axis Compliance.....	21

5. Maintenance	22
5.1 Pneumatics	22
5.2 Lubrication	22
5.3 Bur Inspection	22
5.4 Spindle Motion Inspection	22
6. Troubleshooting and Service Procedures	23
6.1 Troubleshooting	23
6.2 Service Procedures	25
6.2.1 Bur and Collet Replacement	25
6.2.2 Turbine Motor Replacement.....	27
6.2.3 Gimbal Bearing Replacement	33
6.2.4 Ring Cylinder Assembly Replacement.....	34
7. Serviceable Parts	36
7.1 Accessories, Tools, and Optional Replacement Parts	36
8. Specifications	37
9. Terms and Conditions of Sale	38
9.1 Motor Life and Service Interval Statement	39
9.1.1 Turbine Motor Products (RCT models).....	39

Glossary

Term	Definition
Adapter Plate	Device for attaching the RCT-151 to robots or work surfaces.
Aerosols	A suspension of fine solid or liquid particles in gas.
Air Filter	Device for removing contamination from air supply lines.
Burr	Any unwanted, raised protrusion on the work piece.
Bur	Cutting tool used to remove burrs from the work piece. Alternatively referred to as a rotary file, cutter, or bit.
Climb Milling	Cutting method where the direction of cutter rotation and tool motion are the same.
Coalescing Filter	Device designed to remove liquid aerosols from the supply air lines.
Collet	Gripping device used to hold cutting tools in the spindle.
Compliance	The ability of the spindle to passively move in response to protrusions on or deviations of the work piece.
Conventional Milling	Method of cutting where the direction of tool motion is opposite that of tool rotation.
Deburr	To remove the burrs from a machined piece of machined work.
Regulator	Device used to set and control the supplied air pressure to lower acceptable levels.
Solenoid Valve	Electrically controlled device for switching air supplies on and off.
Spindle	The rotating portion of the RCT-151 assembly.
Turbine Motor	Component of RCT-151 that drives the spindle.
-E	Euro models.

1. Safety

The safety section describes general safety guidelines to be followed with this product, explanations of the notifications found in this manual, and safety precautions that apply to the product. Product specific notifications are imbedded within the sections of this manual (where they apply).

1.1 Explanation of Notifications

These notifications are used in all of ATI manuals and are not specific to this product. The user should heed all notifications from the robot manufacturer and/or the manufacturers of other components used in the installation.



DANGER: Notification of information or instructions that if not followed will result in death or serious injury. The notification provides information about the nature of the hazardous situation, the consequences of not avoiding the hazard, and the method for avoiding the situation.



WARNING: Notification of information or instructions that if not followed could result in death or serious injury. The notification provides information about the nature of the hazardous situation, the consequences of not avoiding the hazard, and the method for avoiding the situation.



CAUTION: Notification of information or instructions that if not followed could result in moderate injury or will cause damage to equipment. The notification provides information about the nature of the hazardous situation, the consequences of not avoiding the hazard, and the method for avoiding the situation.

NOTICE: Notification of specific information or instructions about maintaining, operating, installing, or setting up the product that if not followed could result in damage to equipment. The notification can emphasize, but is not limited to: specific grease types, best operating practices, and maintenance tips.

1.2 General Safety Guidelines

Prior to purchase, installation, and operation of the RCT-151, the customer should first read and understand the operating procedures and information described in this manual. Never use the RCT-151 for any purposes, or in any ways, not explicitly described in this manual. Follow installation instructions and pneumatic connections as described in this manual.

All pneumatic fittings and tubing must be capable of withstanding the repetitive motions of the application without encountering failure. The routing of pneumatic lines must minimize the possibility of stress/strain, kinking, rupture, etc. Failure of critical pneumatic lines to function properly may result in equipment damage.

1.3 Safety Precautions



DANGER: Never use the RCT-151 for purposes other than robotic deburring. If used in any other way, serious injury or damage to equipment may occur.



WARNING: All personnel, who are involved in operation of the RCT-151, should have a thorough understanding of the operating procedures. Failure to follow these procedures or neglecting safety precautions can create hazardous situations that may injure personnel or damage the deburring installation and the RCT-151.



WARNING: Never operate the RCT-151 without wearing hearing protection. High sound levels can occur during cutting. Failure to wear hearing protection can cause hearing impairment. Always use hearing protection while working in proximity of the RCT-151.



WARNING: Never operate the RCT-151 without wearing eye protection. Flying debris can cause injury. Always use eye protection while working in the proximity of the RCT-151.



CAUTION: Do not use burs rated for less than the speed of the RCT-151 being used. Using lower rated burs may cause injury or damage equipment. Always use burs rated for at least the speed of the RCT-151 being used.



CAUTION: Do not use spare parts other than original ATI spare parts. Use of spare parts not supplied by ATI can damage equipment and void the warranty. Always use original ATI spare parts.



CAUTION: Never be present near the RCT-151 while it is started or in operation. Flying debris and rotating parts can cause injury. If it is necessary to approach the RCT-151 while in motion, stand behind appropriate Plexiglas windows. Provide a barrier to prohibit people from approaching the RCT-151 while in operation.



CAUTION: Never use or start the RCT-151 without first reading and understanding the operating procedures described in this manual. Never use the RCT-151 for any purposes, or in any ways, not explicitly described in this document. Using the RCT-151 without fully understanding the installation and operating procedures may cause injury to personnel or damage to equipment. Mount the RCT-151 and connect the pneumatic control equipment as described in this manual. Operate the RCT-151 as described in the manual.



CAUTION: Do not perform maintenance or repair on the RCT-151 unless the tool is safely supported or docked in the tool stand and air has been turned off. Injury or equipment damage can occur with tool not docked and air on. Dock the tool safely in the tool stand and turn off the air before performing maintenance or repair on the RCT-151.

NOTICE: Turbine motors are not serviceable at this time. Refer to [Section 9—Terms and Conditions of Sale](#). To maximize the life of turbine motor products the customer should closely follow the normal operation procedures outlined in the product manual. Refer to [Section 4.2—Normal Operation](#). The air must be totally lube-free and filtered to remove particulates and moisture. Exposing the turbine motors to oil in the air supply results in premature failure.

2. Product Overview

The radially compliant deburring tool (RCT-151) is a robust, high-speed and lightweight turbine-motor driven deburring unit for deburring aluminum, plastic, steel, etc. with a robot. The RCT-151 is especially suited for the removal of parting lines and flash from parts. However, its flexible design allows it to be used in a wide variety of applications.

The RCT-151's pneumatically controlled, articulated design allows the cutting bit to follow the part profile and compensate for surface irregularities while maintaining a constant, settable force. This allows high feed rates with uniform quality in any orientation. The tool also requires no oil, allowing clean exhaust air to be vented directly into the work environment.

Compliance is supported by air pressure applied to the shaft of the unit and is used to perform consistent deburring on irregular part patterns. The motor's internal governor maintains high spindle speeds for optimum surface finish. The RCT-151 also utilizes standard industrial tungsten-carbide bits which allow for adaptation to changing assembly lines and part requirements.

The RCT-151 provides for two mounting types—side and axial mounting. The side mounting utilizes two locating dowel pins and four threaded holes. The axial mounting utilizes a tapered flange that requires an adapter plate. Custom adapter plates for both side and axial mounting are available from ATI.

The RCT-151 is equipped with (2) 1/8 NPT ports to supply the motor and compliance air (-E models are equipped with (2) 1/8 BSPP ports).

A tool collet system secures the cutting bur. Various collet sizes and tools are available to accommodate a variety of applications. The RCT-151 is equipped with a 1/8" collet standard, (-E models are equipped with a 3 mm collet).

For drawing and more information, please refer to https://www.ati-ia.com/app_content/Documents/9630-50-RCT-151.auto.pdf.

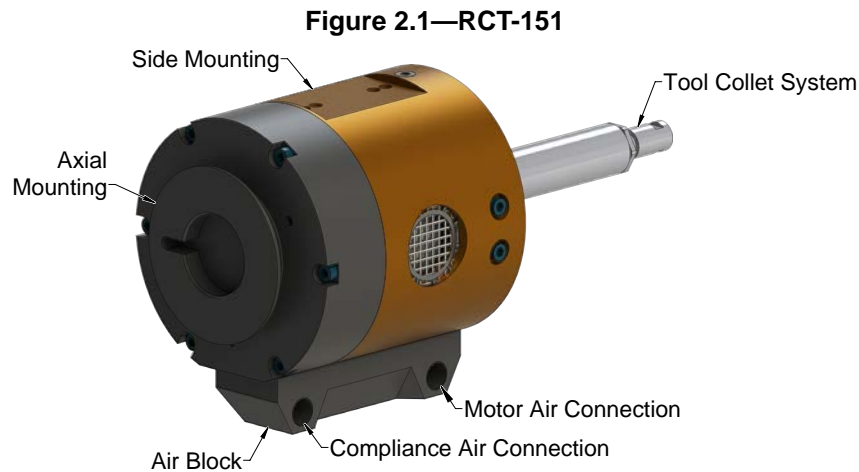

2.1 Tool Collet Systems

A collet system secures the bur to the tool. Various collet sizes are available to accommodate different applications. The RCT-151 uses a 1/8" collet (3 mm for E-models), which utilizes removable collets to grip customer-supplied cutting tools. Different collet diameters may be substituted to retain numerous cutter shank diameters.

The collet retaining nut is loosened to open the collet, allowing cutting tools to be removed and inserted. Once the tool is set to the desired depth, spanner wrenches are used to tighten the collet nut causing the collet to collapse and secure the cutting tool. The turbine motor design does not allow the installation of quick-change or drawbar collet systems.

The standard tool holding system for RCT-151 is an economical, proprietary, single-angle collet design utilizing multiple gripping fingers. This is suitable for most applications where industry standard shank diameter cutting tools are used and runout tolerances of up to 0.001" (0.025 mm) are acceptable.

2.2 Technical Description

A general description of the RCT-151 is provided in [Section 2—Product Overview](#). The following is a technical overview of the product.

2.2.1 Environmental Limitations

2.2.1.1 Operation

Table 2.1—Operation	
Installation position	Mounted to robot by means of the side mounting pattern or rear adapter flange. Refer to Section 3.5—Side Mounting Installation and Section 3.6—Axial Mounting Installation . The optional flange is specific to each type of robot and normally supplied by ATI in a blank form suitable for customer modification.
	Mounted to machining center by various means, customer-supplied tool holders/adapters.
Temperature range	5° C–35° C 41° F–95° F
Utilities	The tool requires the following: <ul style="list-style-type: none"> • Clean, dry, filtered, non-lubricated air. • A coalescing filter and filter elements rated 5 micron or better. • Air supplied to the spindle at 6.2 bar (90 psi). • The radial compliance (centering) air must be supplied from a regulated source between 1.0-4.1 bar (15-60 psi).

2.2.1.2 Storage

Table 2.2—Storage	
Temperature range	0° C–45° C 32° F–113° F
Conditions	The tool should be stored in its crate and in a dry place. When not in use, keep the unit in its crate if possible. Consult Section 3.4—Storage and Preventive Maintenance during Storage of this manual.

2.2.2 Compliance Unit Performance

The chart in [Figure 2.2](#) illustrates the variation of compliance force with applied air pressure. Measurements may vary from one product to another and are nominal.

The actual force characteristics are dependent on mounting orientation and the condition of the unit. In applications where the RCT-151 is mounted horizontally, additional compliance air pressure is required to overcome the weight of the motor. Compliance pressure is also dependent upon the material of the work piece, the type of bur tool, and the amount of material removed.

The turbine motor will attempt to maintain the full rate of speed, even under loaded conditions. However, when extremely heavy cuts are taken, the motor may eventually stall. Therefore, multiple, light passes of the RCT-151 are recommended over slow, heavy cuts.

Figure 2.2—RCT-151 Compliance Force Curve (Measured at the Spindle Tip)

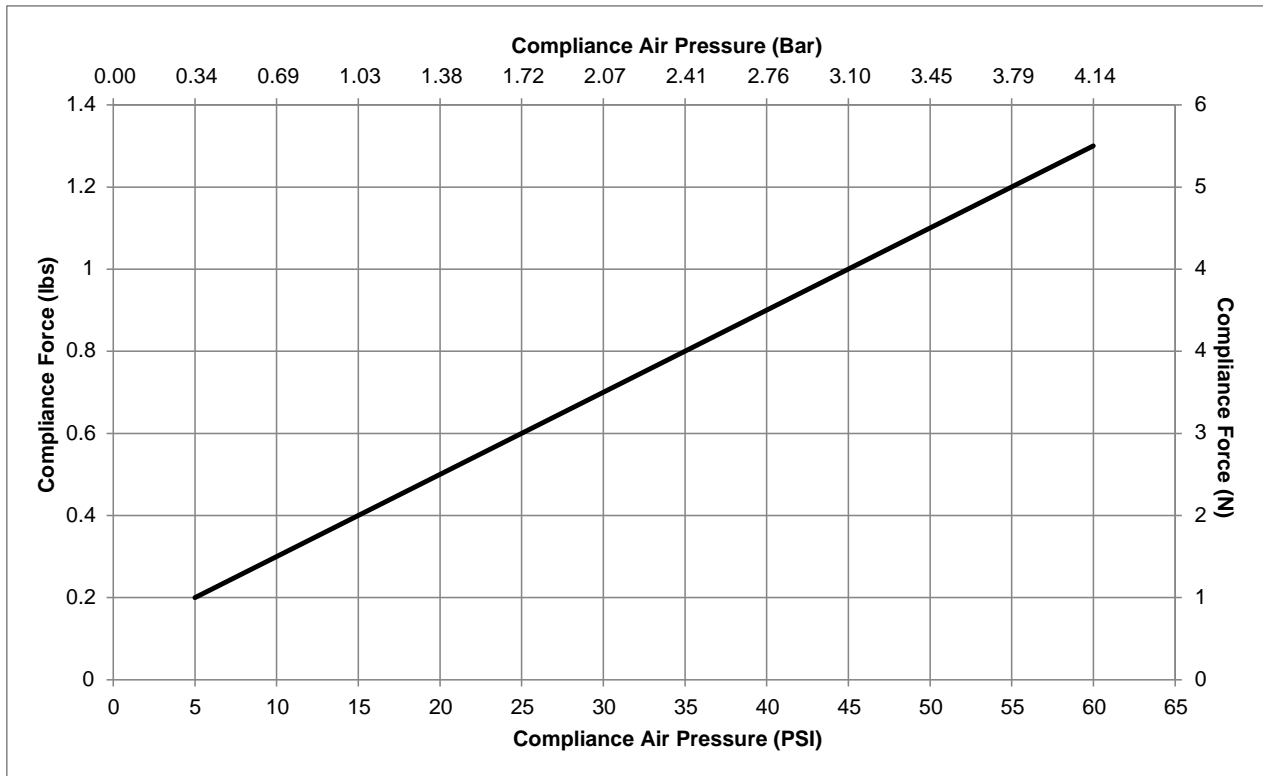

3. Installation

The RCT-151 is delivered fully assembled. Optional equipment such as mounting adapter plates, burr tools, or additional collets, will be separate.

3.1 Transportation and Protection during Transportation

The RCT-151 is packaged in a crate designed to secure and protect it during transportation. Always use the crate when transporting the RCT-151 to minimize the risk of damage.

3.2 Inspection of Condition When Delivered

Upon receipt, the following should be checked:

- Delivery in accordance with freight documents
- Damage to packaging.

If there is damage to any of the packaging, or if any of the goods have been exposed to abnormal handling, unpack the parts that may have been damaged for closer inspection. If necessary, notify ATI for assistance in evaluation of the product condition.

3.3 Unpacking and Handling

The RCT-151 should always be placed inside the accompanying crate during transportation, storage and handling.

Pneumatic lines are attached, bundled, and must be strain-relieved in a manner that allows for freedom of movement during operation.

3.4 Storage and Preventive Maintenance during Storage

The RCT-151 should be stored in its crate when it is not in use. The RCT-151 should also be stored in a dry place. For long-term storage, the RCT-151 should be thoroughly cleaned of any burrs or debris. It should not be disassembled. Place the RCT-151 inside a sealed plastic bag within the crate.

3.5 Side Mounting Installation



CAUTION: The length of the fasteners should not interfere with the compliant motion of the turbine motor spindle. Do not use fasteners that exceed the maximum length; otherwise, damage will occur.



CAUTION: Lock washers are recommended on all mounting features. Liquid thread lockers should not be used for the mounting hardware as this may damage or remove thread inserts during disassembly.

The side mounting pattern of the RCT-151 consists of (2) dowel pin holes and (2) threaded holes. The RCT-151's side mounting feature requires a bench mount adapter plate, available from ATI (Part Number: 9005-50-1054).

Figure 3.1—Bench (Side) Installation

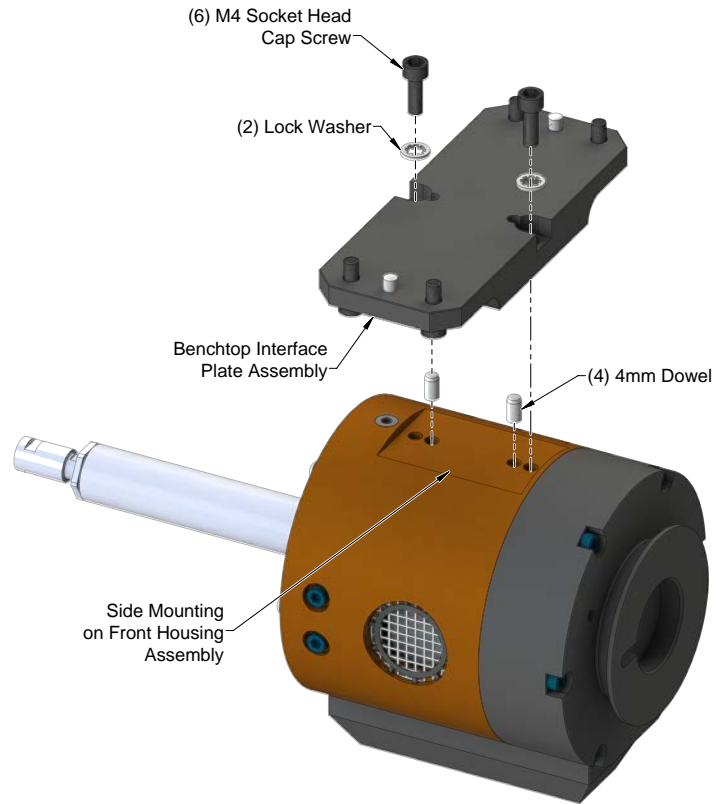

3.6 Axial Mounting Installation

A blank robot adapter plate is available to allow axial mounting off the rear of the RCT-151 housing. This plate may be modified by the system integrator or by the owner/user of the RCT-151. ATI can provide custom interface plates and adapters upon request. The axial mounting requires a clamping collar kit which includes the blank rear adapter plate. The kit is available from ATI (Part Number: 9005-50-1005).

Figure 3.2—Axial Installation (Model shown for reference)

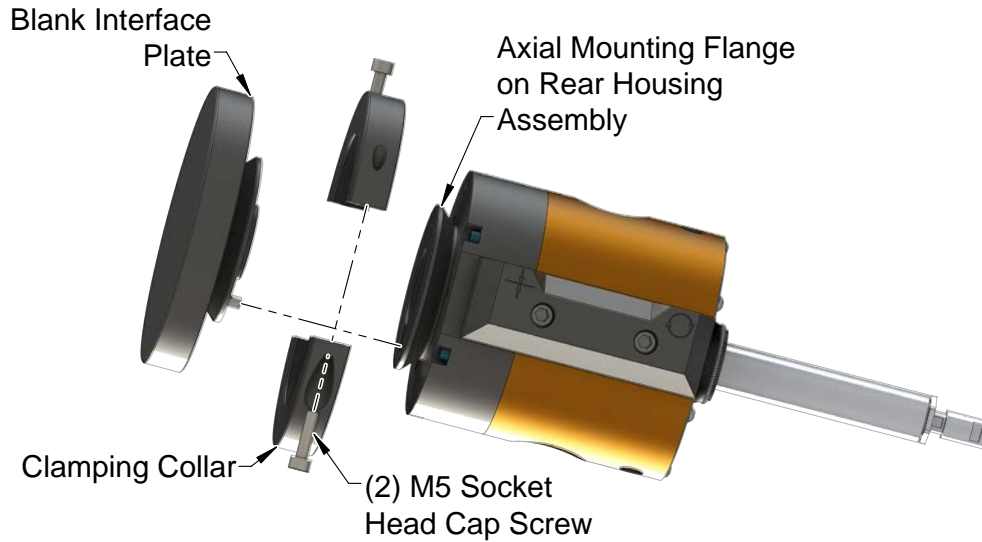

3.7 Pneumatics

Connect the RCT-151 as shown:

Figure 3.3—Pneumatic Connections

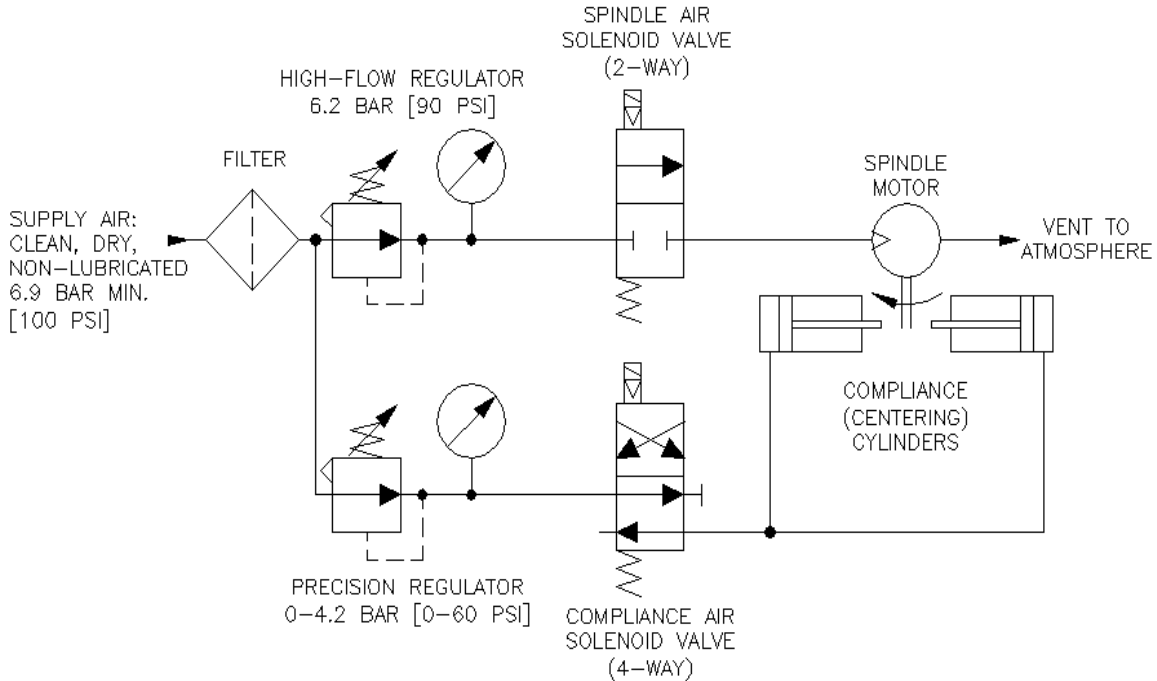

 **WARNING:** All pneumatic fittings and tubing must be capable of withstanding the repetitive motions of the application without failing. The routing of pneumatic lines must minimize the possibilities of pullout and over-stressing or kinking the lines. Failure to properly attend to pneumatic line routing may cause the critical pneumatic lines to malfunction, resulting in damage to equipment.

The air supply should be dry, filtered, and free of oil. A coalescing filter with elements rated for 5 micron or better is required.

A high-flow air pressure control regulator is required to supply the spindle motor at 90 psi (6.2 bar). A second, precision, self-relieving regulator will supply air for the compliance or centering force. The compliance force air supply pressure regulator should have a 1.0-4.1 bar (15-60 psi) range. When testing for the proper contact force, start with about 15 psi (1 bar) of pressure and increase the pressure slowly until the desired cut is achieved.





CAUTION: Pneumatic components used for the motor drive circuit must be capable of meeting the air consumption requirements (see [Section 8—Specifications](#)). Poor performance will result if incorrect components are used.

Conventional, customer-supplied, pneumatic components are used to control the air supply to the RCT-151. ATI recommends that the user install a high-flow pneumatic pressure regulator and a high-flow valve to properly supply a stable air supply of 90 psi (6.2 bar) to the spindle motor. The RCT-151 will not operate properly if the supplied air is below 90 psi (6.2 bar).

A second, precision, self-relieving regulator and valve are used to supply the compliance (centering) mechanism. This pressure corresponds to the side force on the rotary bur. Very little airflow is required for the compliance mechanism. This allows for a significantly smaller valve to be used. The regulator is available from ATI upon request. Consult the valve and regulator supplier’s literature when selecting these components.

If the complete work piece can be deburred with equal force, a conventional, manual, pressure regulator can be used for compliance. If the burrs to be removed vary by location on the work piece, and this variation is repeatable for all work pieces of the same type, it may be necessary to adjust the force using an analog pressure regulator controlled from the robot. An analog output port in the robot or logic controller will be needed.

Solenoid valves are actuated from the robot or program logic controller by means of a digital output signal.

Table 3.1—Pneumatic Connections		
Function	Connection Type	Pressure
Motor Inlet 	1/8 NPT Port for customer connection (1/8 BSPP motor air for -E models)	90 psi [6.2 bar]
Compliance (Radial) Force Inlet 	1/8 NPT Port for customer connection (1/8 BSPP compliance air for -E models)	15-60psi [1.0–4.1 bar]
Exhaust	Vented to Atmosphere through the Housing	Not Applicable

Flexible plastic tubing should be used for the motor air supply and the compliance force air supply.

The turbine motor is extremely quiet and vents dry air to the environment through the screen-covered ports on the side of the housing. Mufflers are not required. Information on the sound intensity is provided in [Section 8—Specifications](#). To reduce the sound from the cutting operation, a customer-supplied barrier surrounding the deburring tool setup may be installed (Plexiglas® or Lexan™ is preferred, see [Section 8—Specifications](#)).

4. Operation

These operating instructions are intended to help system integrators program, start up, and complete a robotic deburring cell containing a RCT-151. The system integrator should be familiar with automation-incorporating robots and the task of deburring.

4.1 Safety Precautions



WARNING: Never operate the RCT-151 without wearing hearing protection. High sound levels can occur during cutting. Failure to wear hearing protection can cause hearing impairment. Always use hearing protection while working in the neighborhood of the RCT-151.



WARNING: Never operate the RCT-151 without wearing eye protection. Flying debris can cause injury. Always use eye protection while working in the neighborhood of the RCT-151.



CAUTION: Do not use burs rated for less than the speed of the RCT-151 being used as it may cause injury or damage equipment. Always use burs rated for at least the speed of the RCT-151 being used.



CAUTION: Do not use spare parts other than original ATI spare parts. Use of spare parts not supplied by ATI can damage equipment and void the warranty. Always use original ATI spare parts.



CAUTION: Never be present near the RCT-151 while it is started or in operation. Flying debris and rotating parts can cause injury. If it is necessary to approach the RCT-151 while in motion, stand behind appropriate Plexiglas windows. Provide a barrier to prohibit people from approaching the RCT-151 while in operation.



CAUTION: Never use or start the RCT-151 without first reading and understanding the operating procedures described in this manual. Never use the RCT-151 for any purposes, or in any ways, not explicitly described in this document. Using the RCT-151 without fully understanding the installation and operating procedures may cause injury to personnel or damage to equipment. Mount the RCT-151 and connect the pneumatic control equipment as described in this manual. Operate the RCT-151 as described in the manual.

4.2 Normal Operation

The following sections describes the normal operating conditions for the RCT-151.

4.2.1 Air Quality

The air supply should be dry, filtered, and free of oil. A coalescing filter with elements rated for 5 micron or better is required. The air must be supplied at 6.2 bar (90 psi).

Air quality affects tool performance more than almost any other factor. Particulate can block airflow. If RCT-151 do not receive proper air pressure, the tool stalls. Any water in the system damages the housing and blades.

4.2.2 No Lubrication

Lubrication of any kind is strictly prohibited.

Turbine motors cannot have any oil in the motor air supply. Oil damages the speed regulator and causes the motor speed to fluctuate out of tolerance.

4.2.3 Bur Selection, Design, and Maintenance

Use a carbide media.

Do not use media that is rated below the RCT-151 idle speed.

Check media quality regularly to ensure it is not dull or worn. Using worn media causes a poor surface finish and increased wear on the bearings that results in premature tool failure.

Do not use shank extensions because the large moment loads combined with the high speed can be dangerous.

Brushes are not recommended because the maximum rated speed of the brush is less than the operating speed of the RCT-151. Operating the brush above its maximum rated speed can be unsafe due to unbalanced loading. Additionally, even balanced brushes can result in an excessive load on the motor and reduced motor life.

Do not use media that requires axial loading on the RCT-151.

4.2.4 RCT-151 Approach Path Should be Slow and at an Angle

The RCT-151 should approach the workpiece slowly and at an angle.

When beginning a deburring pass, try to minimize the initial impact on the work piece by slowly approaching the tool at an angle while maintaining a slightly parallel path with the surface.

If the tool quickly approaches perpendicularly to the workpiece, the result is gouging and premature wear of the tool bearings and bur. Additionally, collisions could result and create a hazardous situation for both personnel and equipment.

4.2.5 No Axial Loading

Do not apply axial loads that are parallel to the axis of the tool's rotation.

Do not deburr shallow edges where the cutter contacts the parent material below the edge; otherwise, axial loading is applied on the tool and bearings and results in premature failing of the unit.

When deburring holes, interpolate the perimeter. Do not use a countersink tool; otherwise, axial loading occurs and causes premature wear on the bearings.

4.2.6 Perpendicular Loading while Locked to Single Axis

Do not apply radial loads that are perpendicular to the axis of pivot. Always keep the tool pivoting perpendicular to the deburring surface. Loading the tool along the pivot axis will damage the pivot pins and cause premature failure.

4.3 RCT-151 Working Environment

As described in previous sections, the RCT-151 should only be used in conjunction with a robot in a secured work cell/chamber.

The work cell must be secured by means of barriers to prohibit personnel from entering the cell. A lockable door should be included as a part of the barrier in order to facilitate access to the cell for authorized personnel only. The barrier could consist partly or fully of Plexiglas to facilitate observation of the deburring operations.

During system or RCT-151 maintenance, make sure the RCT-151 and robot are stopped before entering the robot cell. When installing and testing, never be present in the cell when the RCT-151 is running.

Be aware of rotating parts. Use eye-protection while working around the RCT-151.

Be aware of high sound levels. While the RCT-151 air motor is not loud, the cutting action associated with deburring frequently is loud. Always use hearing protection while working in the neighborhood of the deburring cell.

The RCT-151 should not be used to deburr materials that are prone to fracture. A fracturing work piece may result in pieces of material damaging surrounding working environment and personnel. Material removed correctly should be in the form of chips.

4.4 Tool Center Point (TCP) Position and Programming

Figure 4.1 shows the RCT-151 dimensions. The RCT-151 provides radial compliance and performs best when the cuts taken are not excessively deep. The RCT-151's spindle must never be running while programming the robot. During teaching, the compliance air must be on and supplied above a minimum of 1.0 bar (15 psi).

Suggested programming methods include the following: for the first method, in place of a cutting tool, a dowel pin of suitable diameter is installed to the RCT-151 to simulate the cutter shank diameter when teaching the robot path. For example, for 1/8" collets, a 1/8" diameter dowel pin of adequate length will be inserted in the tool's collet. After teaching, the diameter of the cutter installed should not exceed that of the dowel pin by more than the compliance of the RCT-151. The dowel pin should extend a sufficient distance from the collet to reach the surface on the burr where cutting is desired (see *Figure 4.1*).

The second programming method is to teach the path using the center line of the burr as a guide. Follow the edge of the part, then manually or automatically add offsets to the robot path points to achieve the final correct burr path (see *Figure 4.2*).

The programming method used will depend on the robot's capabilities and programmer preferences.

Figure 4.1—RCT-151 Dowel Teaching Tool

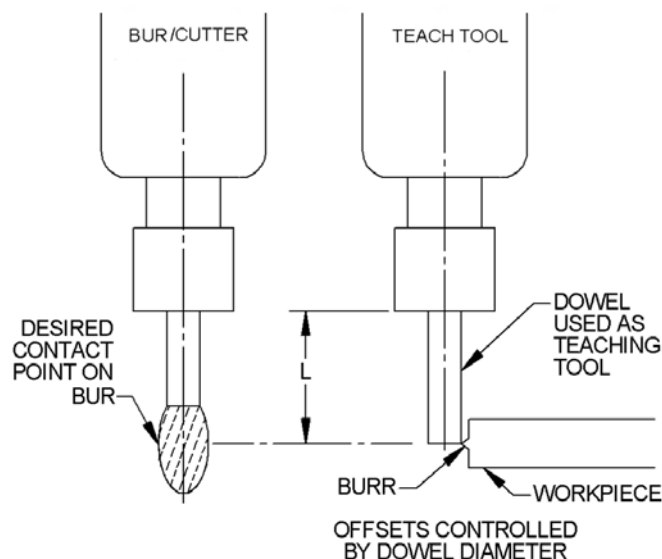
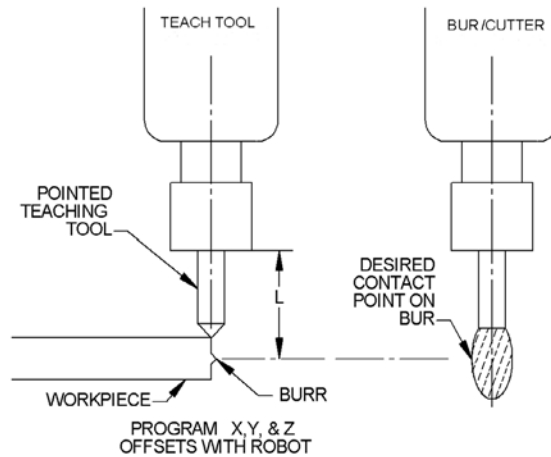

Figure 4.2—RCT-151 Pointed Teaching Tool



Inside corners present a complex situation for compliant RCT-151. The cutter must not be allowed to simultaneously contact both perpendicular surfaces of an inside corner. Should this occur, the resulting force imbalance in two planes will cause severe tool chatter. The customer is advised to create a tool path that will prevent the cutter from simultaneously contacting two perpendicular surfaces. For example, a tapered cutter may reach further into an inside corner if the tool is oriented at an incline and the corner is contacted by the extreme tip of the tool (Note: When working near the tip of a tapered cutter, the surface cutting speed is reduced).

When deburring inside radii, a similar situation may arise. No attempt should be made to deburr an inside radius less than 1.5 times the diameter of the cutter in use ($R_{\min} = 1.5 \times \text{Cutter diameter}$). Failing to follow these guidelines may cause excessive cutter contact, resulting in excessive tool chatter.

The speed at which the RCT-151 is utilized should always correspond with the speed at which the robot was programmed. Note that when the robot path speed is increased, the robot may deviate from the programmed path. When running the robot program the first time, turn the radial compliance air supply down to approximately 1.4 bar (20 psi). Observe the tool's path when the robot program is run to verify that the bur is deflected and also contacts the work surface at operational robot path speed. Once this is confirmed, the compliance force of the bur can be adjusted (as described in [Section 3.7—Pneumatics](#)) in order to achieve a correct depth of cut.

4.5 Cutter Operation and Bur Selection

The RCT-151 will perform best in 'climb milling,' when the cutter's traverse and rotational direction are the same. In the case of the RCT-151, the cutter rotation is clockwise when viewed from above. Climb milling would therefore involve clockwise motion around the part being deburred. In climb milling, the heaviest cut is made as the tool enters the work piece and the chip becomes narrower as the cut is completed.

In 'conventional milling,' the cutter travels in a direction opposite to the cutter's rotation. While this may aid in cutter stability for some operations, the cutting edge of the tool is subjected to higher friction and cutting forces. Thus in this mode, tool wear is accelerated and surface finish quality may be reduced. Additionally, extra care must be taken around corners as this poses a potential hazard where the cutting force can deflect the bur, causing the bur to break as the robot continues along its path.

The selection of a cutting tool is highly dependent upon the depth of cut, as well as the part's material and geometry. Not all selection possibilities are presented in this document. See [Section 4.5.1—Bur Selection](#) for a short list of burs and suitable applications. Note that a specific family of burs is available for working with die cast alloys, aluminum, and plastics. These cutters have fewer teeth and increased relief to minimize chip loading.





Plastics present a challenge due to the phenomenon of chip re-welding. In this process, if the cutter is dull or the feeds and speeds are not correct for the material removed, the chip will melt and weld to the cutter or work piece. This can quickly load a cutter and produce unwanted results. Generally, to minimize chip re-welding, the traverse or feed rate of the RCT-151 will be higher for plastics. This results in larger cuts, which more effectively remove heat from the cutter-tool interface.

4.5.1 Bur Selection

Standard length commercial burs are used with RCT-151. The length of these tools is typically around 2” for 1/4” shank diameter burs (50 mm for 6 mm diameter). Avoid the longer shank burs available from industrial suppliers that appear in catalogs described as, “long” or “extended” shank. Using extended or long shank burs in the RCT-151 will place higher loads and vibrations on the motor bearings resulting in reduced motor life. Bearing failure caused by the use of extended shank burs is not covered under the warranty.

	CAUTION: Do not use long or extended shank burs with the RCT-151. Long shank tools can lead to premature failure of the turbine motor. Failure due to the use of long shank tools is not covered under warranty.
---	---

ATI can provide guidance in bur selection; however, only experimentation will yield the desired results. The following table is presented to assist in burr selection. The table is not comprehensive but includes common burr types and recommended applications.

Table 4.1—Bur Selection		
	Materials/Application	Features/Benefits:
	9150-RC-B-17203 - Double Cut, 1/8” Burr Diameter, 9/16” Burr Length, 1/8” Shank <ul style="list-style-type: none"> • For hardened and tough materials, super alloys, stainless steel, alloyed cast steel and fiber reinforced plastics. • Edge and surface working. • Built up Welds of high-tensile strength in mold and die making. 	<ul style="list-style-type: none"> • Higher cutting capacity than standard cuts. • Smoother finish for surface treatments.
	9150-RC-B-17903 - Double Cut, Flame, 1/8” Burr Diameter, 1/4” Burr Length, 1/8” Shank <ul style="list-style-type: none"> • Universal Use. • For ferrous and Non-ferrous metal, plastics. • Rough finishing of castings • Surface working. • Weld removal. • Brazed welds. 	<ul style="list-style-type: none"> • Smoother operation. • Improved tool control. • High cutting action. • Non-clogging. • Smaller chips, reduced slivers. • Even, smooth surfaces.
	9150-RC-B-18053 - Double Cut, 1/8” Burr Diameter, 9/16” Burr Length, 1/8” Shank <ul style="list-style-type: none"> • For hardened and tough materials, super alloys, and stainless steel, alloyed cast steel and fiber reinforced plastics. • Edge and surface working. 	<ul style="list-style-type: none"> • Higher cutting capacity than standard cuts • Smoother finish for surface treatments.
	9150-RC-B-73003 - Cut, 1/8” Burr Diameter, 1/2” Burr Length, 1/8” Shank <ul style="list-style-type: none"> • For trimming and contour milling of all glass and carbon fiber reinforced plastics 	<ul style="list-style-type: none"> • Special cut geometry allows high feed rates due to low cutting forces.

4.6 Locking the Tool to Single Axis Compliance

The deburring tool can be locked to be compliant in single axis. Included are (4) M3 socket button head screws to lock the tool.



CAUTION: Do not use improper length screws for locking the tool axis. Improper length screws can cause damage to equipment and/or personnel. Use only M4 x 20 mm socket button head cap screws to lock axis.

Tools required: 2.5 mm hex key, torque wrench

Supplies required: Loctite 222 Threadlocker

1. Remove and/or lock-out the spindle motor air supply for safety.
2. Using a 2.5 mm hex key, remove the (4) M4 socket button head cap screws from around the center of the tool body.

Figure 4.3—Remove M4 Socket Button Head Cap Screws

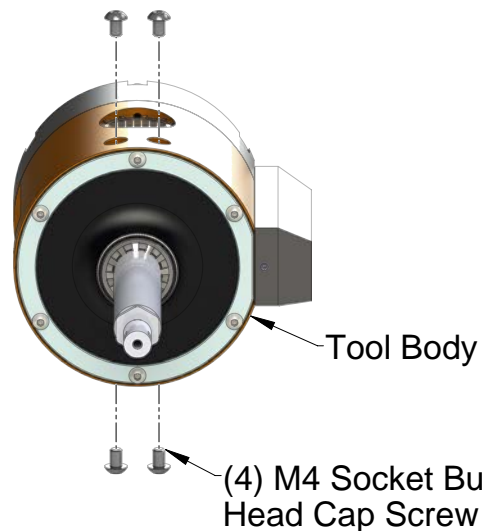

3. Apply Loctite 222 Threadlocker to the (4) M3 socket head cap screws.
4. Using a 2.5 mm hex key, install the (4) M3 socket head cap screws into the screw holes that the (4) M4 socket button head cap screws were removed from. Tighten to 15 in-lbs (1.695 Nm).

Figure 4.4—Install M3 Socket Head Cap Screws

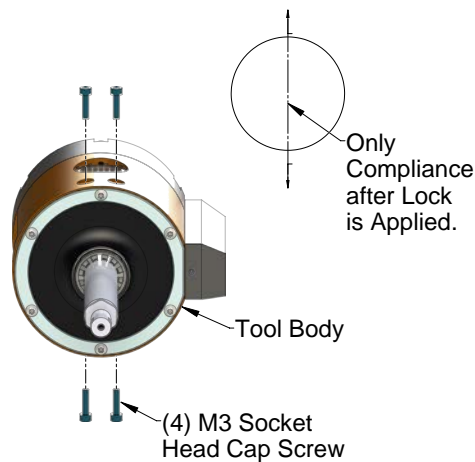

5. Restore the air supply.

5. Maintenance

The RCT-151 is designed to provide reliable service for long periods of operation. The assembly includes some user serviceable parts. The user is encouraged to return the unit to ATI for service. [Section 6—Troubleshooting and Service Procedures](#) is provided to assist the user when they choose to service the unit in the field.

For all service, the air supply (before the solenoid valves) should be disconnected. Drain any trapped air pressure in the lines. The air supply should be ‘locked out’ to prevent accidental operation of the spindle. During maintenance operations, refer to [Section 6—Troubleshooting and Service Procedures](#) for maintenance instructions. Service and repair parts are identified in [Section 6—Troubleshooting and Service Procedures](#) and [Section 7—Serviceable Parts](#).

5.1 Pneumatics

The condition of the air lines to the RCT-151 should be routinely checked and replaced as required. The air to the RCT-151 must be filtered, dry, and non-lubricated. The air filters should be checked and replaced as required to maintain optimum performance. The life of the filter elements is dependent on the quality of compressed air at the customer’s facility and therefore cannot be estimated.

5.2 Lubrication

Lubrication systems are not to be used. The RCT-151 turbine motor must be supplied with clean, dry, filtered air. Oil in the air stream will cause the turbine motor to fail. Failure of the motor due to oil in the air stream is not covered under the warranty. See [Section 3.7—Pneumatics](#) for details on air supply and quality.



CAUTION: Do not use lubricated air with the RCT-151. Oil in the air stream will result in the failure of the turbine motor. Failure due to using lubricated air is not covered under warranty. It is recommended that the customer use a coalescing filter and filter elements rated 5 micron or better.

5.3 Bur Inspection

The bur will wear depending on cut depth, feed rate, and material being deburred. Inspect the bur regularly for wear and refer to [Section 6—Troubleshooting and Service Procedures](#) for symptoms of a worn bur.

5.4 Spindle Motion Inspection

The pivot bearing allows articulation of the motor assembly. The pivot pins in the housing and pivot bearings in the gimbal ring are subject to wear; both components should be replaced when excessive spindle motion is observed. Refer to [Section 6.2.4—Ring Cylinder Assembly Replacement](#)

6. Troubleshooting and Service Procedures

The RCT-151 is designed to provide reliable service for long periods of operation. The assembly includes some user serviceable parts. The user is encouraged to return the unit to ATI for service. The following table is provided to assist the user when they choose to service the unit in the field.

For all service, the air supply (before the solenoid valves) should be disconnected. Drain any trapped air pressure in the lines. The air supply should be ‘locked out’ to prevent accidental operation of the turbine motor spindle. During maintenance operations, refer to [Section 6.2—Service Procedures](#) for maintenance instructions. Service and repair parts are identified in this section and [Section 7—Serviceable Parts](#).

6.1 Troubleshooting

Deburring process development is an iterative, learning task. The following table is presented to assist in solving deburring problems.

Table 6.1—Troubleshooting		
Symptom	Cause	Resolution
Bur wear	Hard work material	Use better grade burr material add coating (TiAIN).
	Too heavy a cut	Decrease width of cut/make multiple passes.
	Feed rate is too slow	Increase feed rate.
Bur breakage	Too heavy a cut	Decrease width of cut/make multiple passes.
	Deflection at corner	Climb mill; do not begin path at sharp corner.
	Impacting part	Decrease feed rate at contact; enter part at an angle.
Unequal compliance	Worn ring cylinder	Replace ring cylinder; refer to Section 6.2.4—Ring Cylinder Assembly Replacement .
	Pivot bearings and/or pivot pins are worn	Replace gimbal ring pivot bearings/pins. Refer to Section 6.2.3—Gimbal Bearing Replacement .
	Defective Regulator	Replace regulator.
Poor finish on work piece	Feed rate is too fast	Reduce feed rate.
	Bur is worn	Inspect bur if worn, replace. Refer to Section 6.2.1—Bur and Collet Replacement .
	Turbine motor bearings are worn	Inspect spindle shaft, if shaft feels loose or has play, replace the turbine motor. Refer to Section 7—Serviceable Parts .
Bur chattering during cut	Feed rate is too fast	Reduce feed rate.
	Lack of rigidity	Increase radial compliance pressure.
	Too heavy a cut	Decrease width of cut; make multiple passes.
	Improper bur selection	Choose bur designed for work material. Refer to Section 4.5.1—Bur Selection .
	Bur is worn	Inspect bur if worn, replace. Refer to Section 6.2.1—Bur and Collet Replacement .
	Turbine motor bearings are worn	Inspect spindle shaft. If spindle shaft feels loose or has play, replace the turbine motor. Refer to Section 7—Serviceable Parts .

Table 6.1—Troubleshooting

Symptom	Cause	Resolution
Secondary burrs created on work piece after cut	Incorrect feed rate	Reduce feed rate.
	Too heavy a cut	Decrease width of cut; make multiple passes.
	Improper bur selection	Choose bur designed for work material. Refer to Section 4.5.1—Bur Selection .
	Bur is worn	Inspect bur. If worn, replace. Refer to Section 6.2.1—Bur and Collet Replacement .
	Motor bearings are worn	Inspect turbine motor spindle shaft. If spindle feels loose or has play, replace the turbine motor. Refer to Section 7—Serviceable Parts .
Chip packing of burr	Too heavy a cut	Decrease width of cut; make multiple passes.
	Not enough chip clearance	Use a bur with fewer flutes.
Bur stalls	Not enough or no drive air	Check drive air regulator has 6.2 bar (90 psi) of air, and inspect for leaks.
	Bur is not secure in collet	Properly tighten burr in collet; refer to Section 6.2.1—Bur and Collet Replacement .
	Too much side load	Decrease width of cut/make multiple passes
	Turbine motor needs replacement	Replace turbine motor; refer to Section 7—Serviceable Parts .
Sticking turbine motor spindle	Turbine motor bearings are worn	Replace turbine motor; refer to Section 7—Serviceable Parts .

6.2 Service Procedures

Component replacement and adjustment procedures are provided in the following section:

6.2.1 Bur and Collet Replacement

In normal operation the bur will become worn. If improper feeds and speeds are used, the cutter may become “loaded” with material. In both instances, the cutter will need to be replaced. During initial production, the bur and the work piece should be examined regularly in order to determine at what interval the bur should be replaced. Replacing the collet will not be required when the bur is replaced but may be required when a different sized tool is required. Collet replacement is included in the following procedure:

The following procedure detail replacing the cutter and or collet. Refer to *Figure 6.1—Bur and Collet Replacement*:

Parts required: Refer to *Section 7—Serviceable Parts*.

Tools required: 1/4” (6.4 mm) and 9/32” (7 mm) open-end wrench

1. Remove and/or lock out the turbine motor air supply for safety (De-energize all energized circuits such as air and power).
2. If applicable, disconnect the air hose from the compliance and turbine motor supply air fitting.
3. Remove the RCT-151 from the robot or work piece.
4. Using compressed air and a clean, lint-free rag, remove debris and grease from the outer surfaces of the RCT-151.
5. If the cutter is to be replaced with one of an identical type, measure and record the tool length extending beyond the collet lock nut. Alternatively, the optional ATI 9150-RC-T-4230 bur setting tool accessory can be used to duplicate tool exposure length. Refer to the Supplemental Documentation for Deburring Tools - Bur Setting Fixture Instructions, Document # 9640-50-1005.
6. Use the 1/4” (6.4 mm) open-end wrench to hold the spindle just behind the collet nut.
7. Use the 9/32” (7 mm) collet wrench to turn the collet locknut counter-clockwise (when viewed from the cutter tip) to loosen the collet.

Figure 6.1—Bur and Collet Replacement

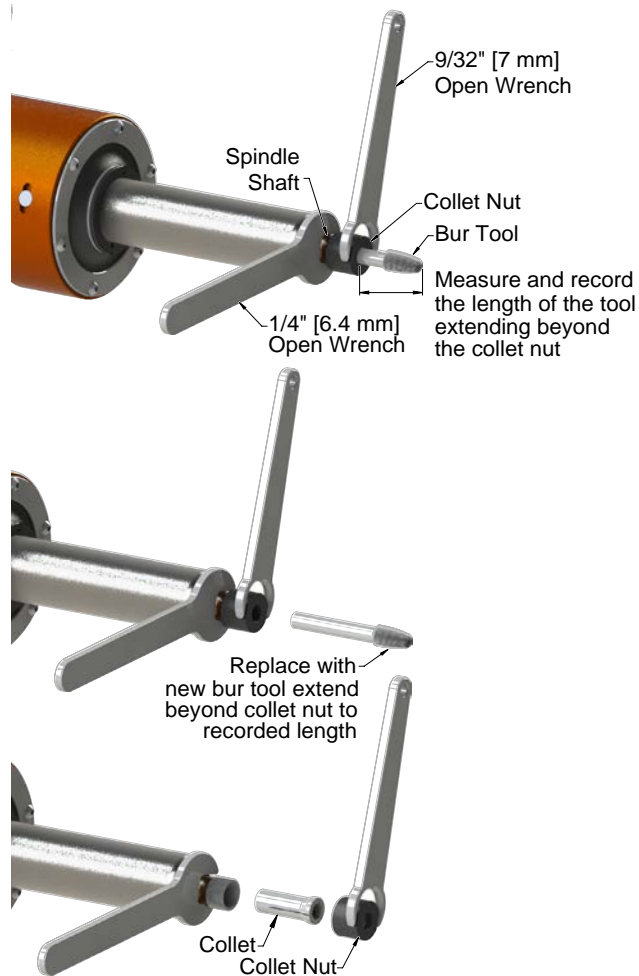

CAUTION: During operation of the RCT-151, the bur reaches high temperatures. Failure to wear proper personal protection equipment or not allowing the bur to cool, could result in serious injury to the user. Be aware that during operation, the bur becomes very hot, and when removing the bur, take necessary safety precautions to avoid injury.

8. To remove a worn cutter, pull the cutter out of the loosened collet.
9. If the collet is being replaced, completely remove the nut and extract the old collet. Insert the new collet and install the nut, leaving it loose.
10. If an identical new cutter is replacing a worn one, measure and adjust the length of its exposed portion according to the measurement taken in step 5.
11. Use the 1/4" (6.4 mm) open-end wrench to hold the spindle just behind the collet nut.
12. Use the 9/32" (7 mm) collet wrench to turn the collet locknut clockwise (when viewed from the cutter tip) to tighten the collet.
13. If applicable, install the RCT-151 to the robot or work location.
14. If applicable, replace hose connections to the compliance and spindle supply air fitting.
15. When the above procedure is complete, all circuits (i.e. air, power) may be placed into normal operation.

6.2.2 Turbine Motor Replacement

If the turbine motor is operated using oil-laden or contaminated air, it will fail and require replacement. Failure of the motor due to contamination in the spindle air is not covered under warranty. The motor may also require replacement after an extended operating life or following a severe collision. The turbine motor does not include any user serviceable parts. RCT-151 units with defective motors should be returned to ATI during the warranty period. Motors are sold as complete, modular assemblies to simplify and expedite user installation. Should the customer wish to replace the motor after the warranty period, perform the following procedure:

Parts required: Refer to [Section 7—Serviceable Parts](#).

Tools required: Small screwdriver, 1.5 mm, 2 mm, 3 mm, and 6 mm hex keys, torque wrench, needle-nose pliers.

Supplies required: Clean, lint-free rag, Industrial grease, Magnalube, Loctite 7649 Primer, and Loctite 222.

1. Remove and/or lock out the turbine motor air supply for safety (De-energize all energized circuits such as air and power).
2. Disconnect the air hoses from the turbine motor and compliance air fittings.
3. Remove the RCT-151 from the robot or work location.
4. Remove the cutting bur. Refer to [Section 6.2.1—Bur and Collet Replacement](#), steps 5 through 9.
5. Using compressed air and a clean rag, remove debris and grease from the outer surfaces of the RCT-151.
6. Ease the garter spring off the front boot.
7. Remove the (6) M3 button head cap screws from the boot ring using a 2 mm hex key. Remove the boot ring securing the front boot to the unit.
8. Remove the front boot.
9. On the air supply block, remove the small M3 set screw visible below/near the spindle air supply port using a 1.5 mm hex key.
10. Using a 3 mm hex key, remove the (2) M4 socket head cap screws securing the air supply block to the side of the unit.
11. Remove the air supply block from the housing flat.
12. Remove the pivot fitting exposed when the air supply block is removed by turning it counterclockwise. Be sure to retain the O-ring located around the pivot fitting and the adjacent O-ring placed between the flat and air supply block.
13. Inspect all seals and fasteners for reuse; replace any worn components.
14. Using a 2.5 mm hex key, remove the (4) M3 socket head cap screws or (4) M4 button head cap screws from the right and left sides of the housing assembly.

Figure 6.2—Air Supply Block and Front Boot Removal

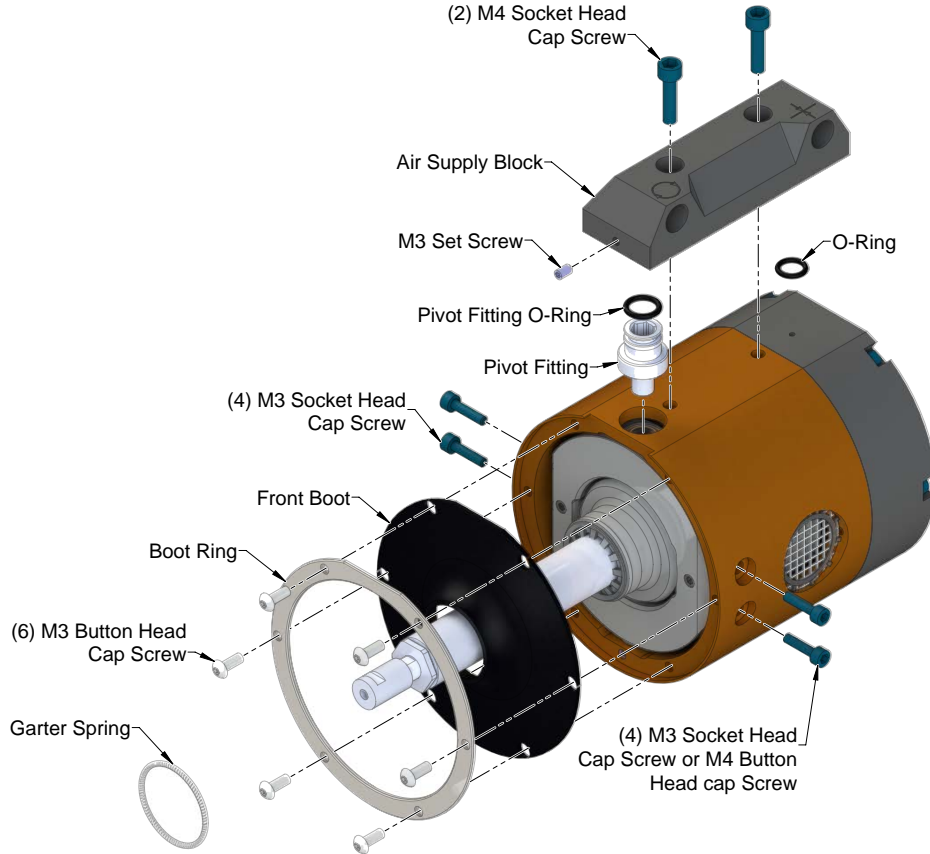

15. Remove the small M3 set screw at the bottom of the front face of the housing using a 1.5 mm hex key.
16. Thread a M3 screw into the pivot pin to aid in extracting the pin. The pivot pin secures the gimbal ring in the housing.
17. With the gimbal ring and air supply ring attached to the motor, remove the turbine motor from the housing.

Figure 6.3—Turbine Motor Assembly Removal

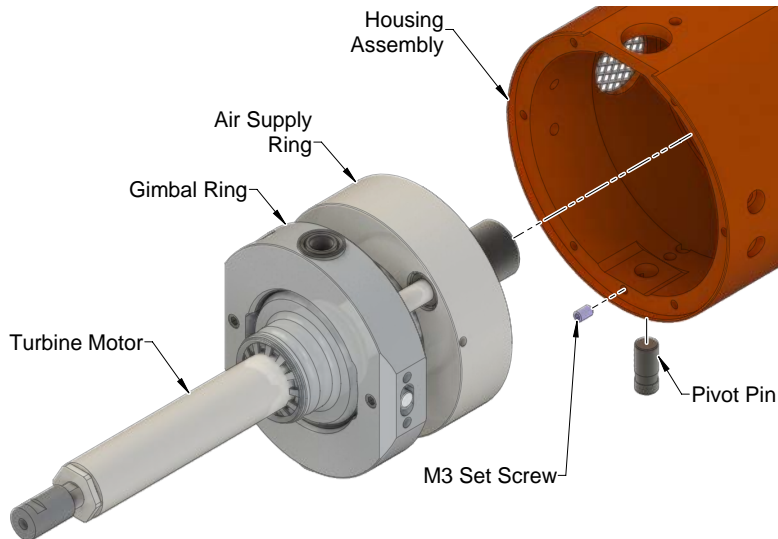

18. Loosen the (3) M3 set screws from the air supply ring using a 1.5 mm hex key.
19. Pull the air supply ring off the turbine motor.
20. Remove the (2) air tubes from the air supply ring.
21. Locate the (2) M4 set screws in the gimbal ring and remove them using a 2 mm hex key.
22. Use needle-nose pliers to remove the gimbal ring pivot pins that were secured by the set screws removed in the previous step.
23. Remove the gimbal ring from the turbine motor; ensure the wave spring on the left pivot pin of the turbine motor comes off with the gimbal ring.

Figure 6.4—Disassemble Turbine Motor Assembly

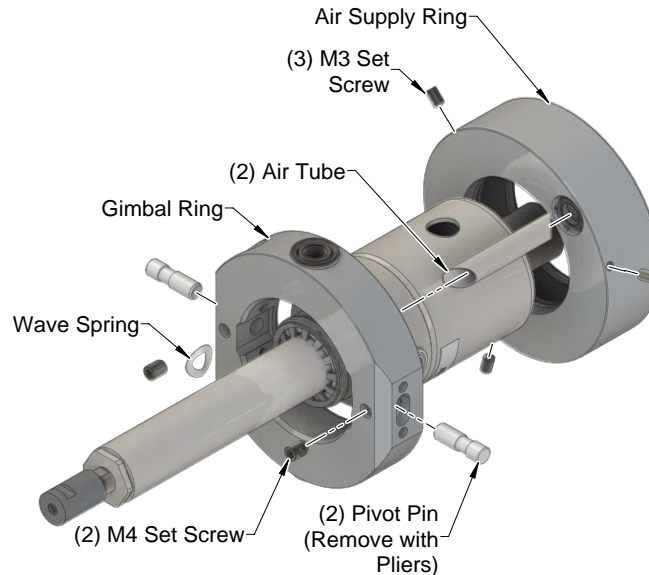

24. Reassembly: Coat the wave spring with light grease and place it on the shoulder inside the gimbal ring prior to sliding the motor assembly in place. The grease will hold the spring in position during this step.

Figure 6.5—Wave Spring Reassembly

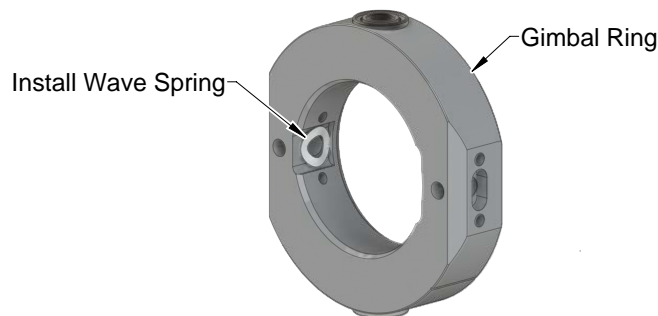

25. Slide the new turbine motor assembly into the gimbal ring, ensuring the wave spring remains in place, then press the two pivot pins through the gimbal ring openings and the bearings on the motor. Note: The undercut band on the pins must be oriented to the outside. The pins should be pressed in flush with the flat surfaces on the gimbal ring.
26. Insert the (2) M4 set screws that secure the pivot pins into the gimbal ring and tighten to 96 in-oz (0.68 Nm) using a 2 mm hex key.

27. Lubricate the outer diameter of the (2) air tubes that go between the outer gimbal ring and the air supply ring prior to their installation, then fit them to the gimbal ring.
28. Lubricate the O-rings on the inside bore of the air supply ring.

Figure 6.6—Install Gimbal Ring and Air Supply Ring on Turbine Motor

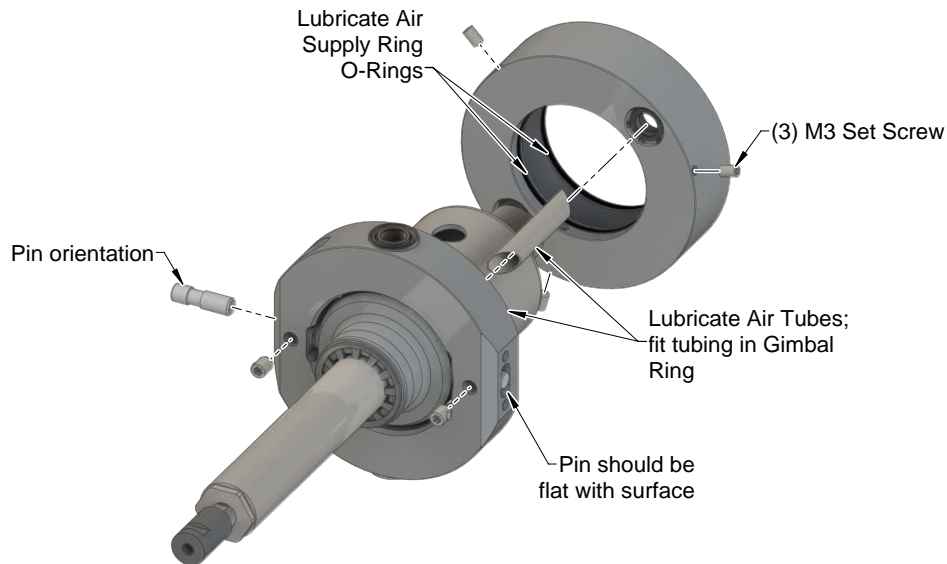

29. Locate and align the axial scribe marks on the gimbal ring and air supply ring.
30. Slide the air supply ring down the motor body. The air tubes from step 20 will enter the seals on the inner face of the air supply ring.
31. Move the air supply ring down the turbine motor body until there is a gap of 0.449" (11.4 mm) between the surfaces of the air supply ring and the gimbal ring.

Figure 6.7—Air Supply Ring, Gimbal Ring Alignment

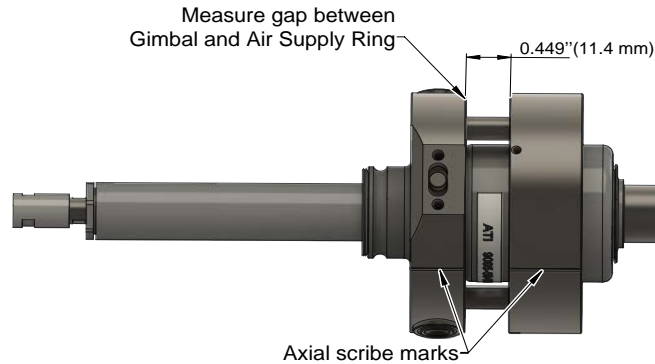

32. Using a 1.5 mm hex key, tighten the (3) M3 set screws securing the air supply ring to the motor body (refer to [Figure 6.6](#) for set screw locations). Torque set screws to 96 in-oz (0.68 Nm).
33. Slide the turbine motor with the gimbal and air supply ring attached into the housing. Move the turbine motor assembly toward the housing flat that holds the air supply block. Continue to slide the motor assembly into the housing until the bearing in the gimbal ring aligns with the threaded hole on the housing flat surface (see [Figure 6.8](#)).
34. Press the pivot pin through the housing and into the gimbal ring bearing (with the extended inner race). Note: The undercut band on the pin must be oriented to the outside (refer to [Figure 6.8](#)). The pin should be pressed in flush with the outside diameter of the housing.
35. Using 1.5 mm hex key, install the small M3 set screw in the front face of the housing to secure the pivot pin. Torque the M3 set screw to 96 in-oz (0.68 Nm).
36. Lubricate the O-ring seal and fit the seal on the pivot fitting. Thread the pivot fitting into the flat of the housing such that it enters the bearing in the gimbal ring without the extended inner race.
37. Tighten the pivot fitting to 40 in-oz (0.28 Nm) then loosen the fitting by 1/6 turn (1 flat of the hex key).
38. Lubricate the counterbore of the air supply block and insert the O-ring seal within the counterbore.
39. Install the air supply block to the flat of the housing.
40. Apply Loctite 7649 Primer and Loctite 222 to the threads of the (2) M4 socket head cap screws that secure the air supply block to the housing.
41. Secure the air supply block to the housing with the (2) M4 socket head cap screws. Use a 3 mm hex key and torque the screws to 25 in-lbs (2.8 Nm).
42. Apply Loctite 222 to the thread on the small set screw for the air supply block.
43. Using a 1.5 mm hex key, install the M3 set screw in the hole visible below the motor-air supply port on the air supply block and torque to 96 in-oz (0.68 Nm).
44. Apply Loctite 222 to the (4) M3 socket head cap screws or (4) M4 button head cap screws and install the screws in the housing assembly.
45. Tighten all (4) M3 socket head cap screws or (4) M4 button head cap screws to contact, then torque each screw to 6 in-lbs using a 2.5 mm hex key.

Figure 6.8—Turbine Motor Installation

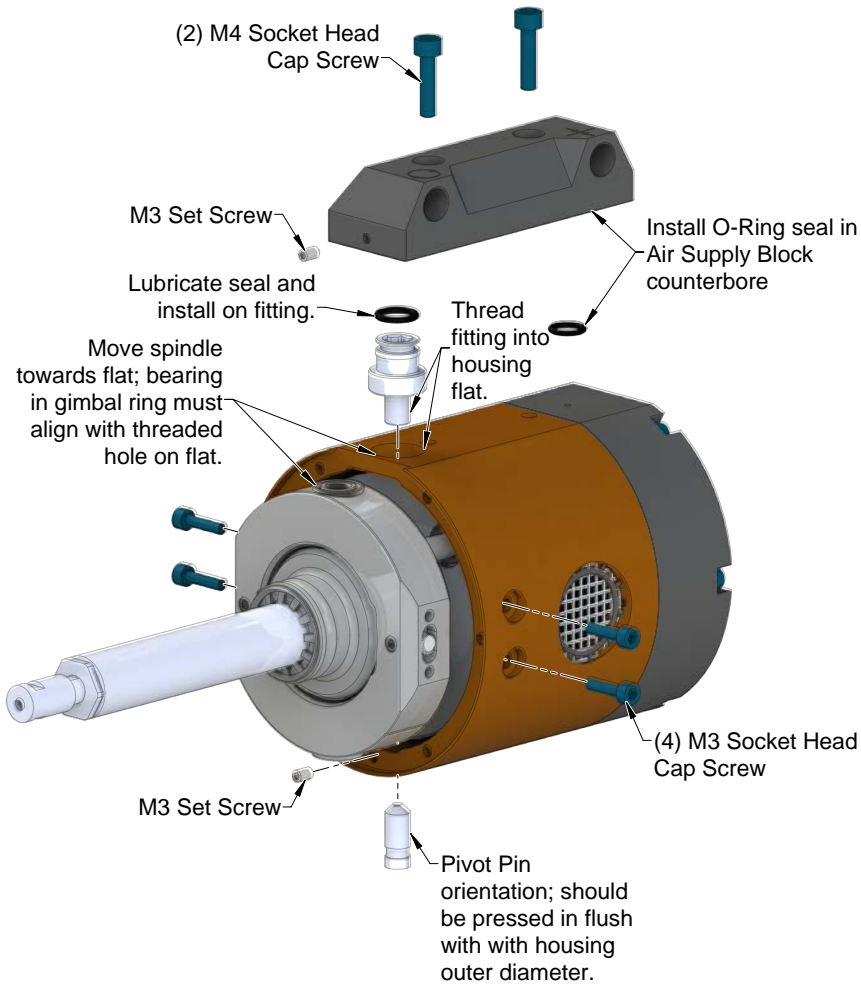

46. Install the front boot to the front of the housing, aligning the holes in the boot and housing.
47. Apply Loctite 7649 Primer and Loctite 222 to the threads of the (6) M3 button head screws of the boot ring.
48. Install the boot ring to the front of the housing and secure with the (6) M3 button head screws. Tighten to 48 in-oz (0.34 Nm).
49. Stretch the center of the boot slightly to fit the collar on the motor, then install the garter spring on the front boot.
50. Safely resume normal operation.

Figure 6.9—Front Boot Install

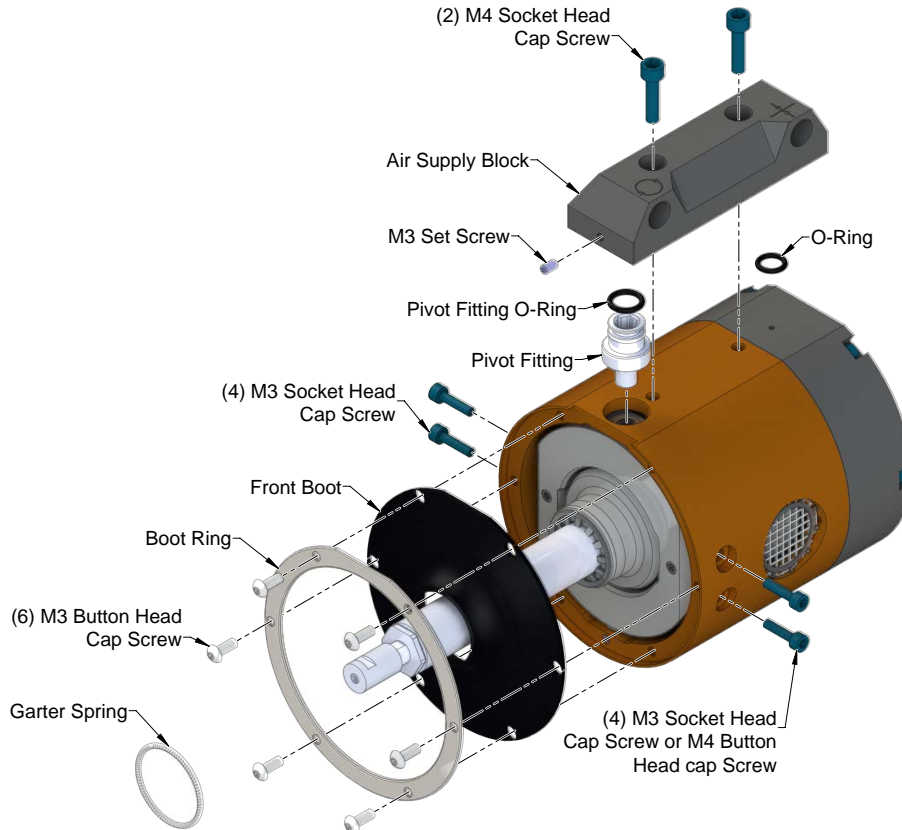

6.2.3 Gimbal Bearing Replacement

Parts required: Refer to [Section 7—Serviceable Parts](#).

Tools required: 1.5 mm, 2 mm, 3 mm, and 6 mm hex key; torque wrench, pliers.

Supplies required: Magnalube, Permatex #2, Loctite 7649 primer, Loctite 222, clean lint-free rag.

1. Remove and/or lock out the turbine motor air supply for safety (De-energize all energized circuits such as air and power).
2. Disconnect the air hoses from the turbine motor and compliance air fittings.
3. Remove the RCT-151 from the robot or work location.
4. Remove the cutting bur, refer to [Section 6.2.1—Bur and Collet Replacement](#) steps 5 through 9.
5. Using compressed air and a clean rag, remove debris and grease from the outer surfaces of the RCT-151.
6. Remove the turbine motor assembly from the housing as described in [Section 6.2.2—Turbine Motor Replacement](#) steps 6 to 23.
7. The pivot bearings of the ring are now accessible; to remove the bearings, use a suitable pair of pliers to grab the outer race and pull the bearing out of the ring (the bearings are only lightly retained). Alternatively, a hooked piece of wire can be inserted in the bearing bore to pull the bearings out.
8. Apply a tiny amount of non-hardening gasket sealant, Permatex #2 or an equivalent, to the outer race of the new bearings to secure them during the reassembly process. Only a small amount is required.
9. Insert the pivot bearing without an extended inner race into the bore with the cup seal at the top of the gimbal ring. Insert the pivot bearing with the extended inner race into the other bore.

Figure 6.10—Gimbal Pivot Bearing Replacement

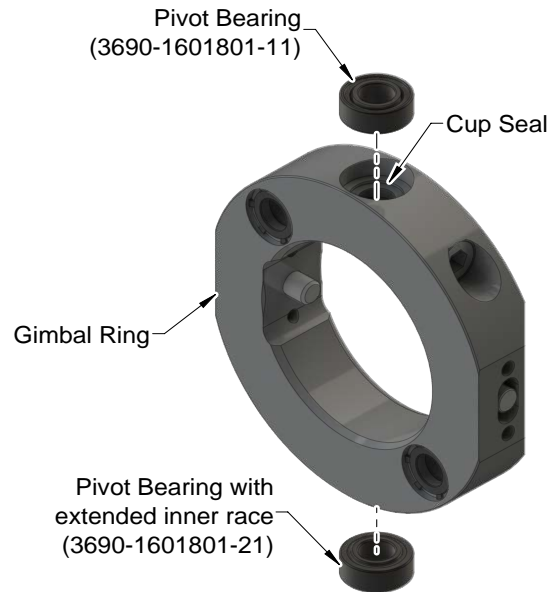

10. Reassemble the RCT-151 assembly as described in steps 24 through 50 in [Section 6.2.2—Turbine Motor Replacement](#).
11. When the above procedure is complete, all circuits (i.e. air, power, etc.) may be placed into normal operation.

6.2.4 Ring Cylinder Assembly Replacement

The compliant motion of the turbine motor spindle is accomplished using a circular array of pistons (ring cylinder) at the back of the housing. After extended operation, this component may need to be replaced to insure free motion of the pistons. The unit may be replaced as an assembly, but its subcomponents are not user serviceable. To replace the ring cylinder assembly, perform the following procedure: The ring cylinder is available as a complete assembly with new O-ring seals.

Parts required: Refer to [Section 7—Serviceable Parts](#).

Tools required: Small screwdriver, 1.5 mm, 2.5 mm, and 3 mm hex keys, torque wrench, needle-nose pliers.

Supplies required: Clean, lint-free rag, Industrial grease, Magnalube, Loctite 7649 Primer, and Loctite 222.

1. Remove and/or lock out the turbine motor air supply for safety (De-energize all energized circuits such as air and power).
2. Disconnect the air hoses from the turbine motor and compliance air fittings.
3. Remove the RCT-151 from the robot or work location.
4. Using compressed air and a clean rag, remove debris and grease from the outer surfaces of the RCT-151.
5. On the air supply block, remove the small M3 set screw visible below/near the spindle air supply port using a 1.5 mm hex key.
6. Using a 3 mm hex key, remove the (2) M4 socket head cap screws securing the air supply block to the side of the unit.
7. Remove the air supply block from the housing flat.
8. Inspect all seals and fasteners for reuse; replace any worn components.
9. Remove the (6) M3 socket head cap screws that secure the rear housing to the front housing.
10. Remove the rear housing.

Figure 6.11—Rear Housing and Ring Cylinder Assembly

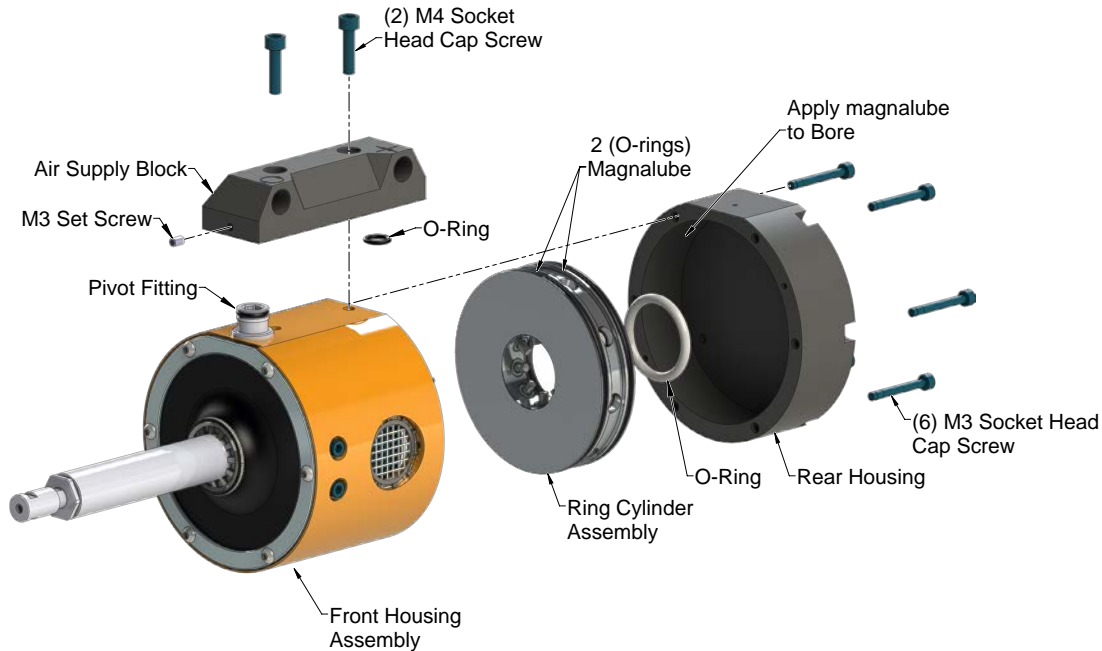

11. There are (3) threaded holes that you can access from the opposite face of the rear housing. Use the (3) M3 screws to push the old ring cylinder out. They will need to tighten them evenly to keep the ring cylinder from binding.
12. Reassembly: prior to the ring cylinder's installation, apply a thin film of grease to the bore in the rear housing assembly where the cylinder will be seated.
13. Use hand pressure and a flat plate to press the ring cylinder into the bore of the rear housing assembly until it reaches the bottom of the housing. The end with the o-ring should be the end that is pressed into the rear housing.
14. Assemble the rear housing to the front housing.
15. If the (6) M3 socket head cap screws do not have pre-applied adhesive, apply Loctite 222.
16. Using a 2.5 hex key, secure the rear housing using the (6) M3 socket head cap screws. Tighten to 12 in-lbs (1.4 Nm).
17. Lubricate the counterbore of the air supply block and insert the O-ring seal within the counterbore.
18. Install the air supply block to the flat of the housing.
19. Apply Loctite 7649 Primer and Loctite 222 to the threads of the (2) M4 socket head cap screws that secure the air supply block to the housing.
20. Secure the air supply block to the housing with the (2) M4 socket head cap screws. Use a 3 mm hex key and torque the screws to 25 in-lbs (2.8 Nm).
21. Apply Loctite 222 to the thread on the small set screw for the air supply block.
22. Using a 1.5 mm hex key, install the M3 set screw in the hole visible below the motor-air supply port on the air supply block and torque to 96 in-oz (0.68 Nm).
23. When the above procedure is complete, all circuits (i.e. air, power, etc.) may be placed into normal operation.

7. Serviceable Parts

For repair and spare parts please contact ATI. Available accessories, tools, and optional replacement parts are listed below. All other repairs must be performed by ATI.

7.1 Accessories, Tools, and Optional Replacement Parts

Table 7.1—Available Accessories, Tools, and Optional Replacement Parts		
Item No.	Part Number	Description
1	9150-RC-B-XXXXX	Refer to Table 4.1 for bur part numbers and descriptions
2	9150-RC-C-12142	Ø 3 mm Collet
	9150-RC-C-12141	Ø 1/8" Collet
	9150-RC-C-12446	Ø 1/4" Collet (Standard on Inch Models)
3	9150-RC-T-12173	Combo Collet Wrench, 1/4" x 9/32" (7 mm x 6.4 mm)
4	9150-RC-C-12149	Collet Nut
5	9005-50-6166	Coalescing Filter Regulator Air Prep Kit w/ Compliance (Dry Air)
6	9150-RC-T-4230	Bur Setting Fixture, RC/RS Tools

8. Specifications

Table 8.1—RCT-151 Specifications	
Parameter	Rating
Motor Type	Turbine
Motor part number	3490-0001026-01
Motor Series	201JSL
Idle Speed (RPM)	65,000 (71,500 Max.)
Power	151 W (0.20 hp) @ 65,000 RPM
Weight (without Adapter)	2.3lbs, 1.05kg
Compensation (Radial)	+/-0.25 in. max., +/-0.12 in. recommended (+/-6.4 mm max., +/-3.2 mm recommended)
Compliance Force (Measured at Collet)	.2lbf to 1.3lbf (.9N to 5.8N) @ 15-60psi (1.0 bar to 4.1 bar)
Bur Surface Speed	Dependent on Cutter Geometry and Motor Speed
Turbine Motor Air Pressure	90 psi (6.2 Bar) (All Models)
Air Consumption (Idle)	3 CFM (1.4 l/s)
Air Consumption (Stall)	8 CFM (3.8 l/s)
Air Connection (Spindle)	1/8 NPT Port for customer connection (1/8 BSPP motor air for -E models)
Air Connection (Compliance)	1/8 NPT Port for customer connection (1/8 BSPP compliance air for -E models)
Sound Pressure Level ¹	78 dBa
Collet Size, Standard ²	1/8" standard (All Modules), 3 mm on -E Models
Rotary Burs ³	Commercial Units Rated 65,000 RPM or Higher
Special Tools	Open End Wrenches (1 Pair Supplied) 1/4" (6.4 mm) 9/32" (7 mm)

Notes:

1. All noise emission measurements were taken under no load idle conditions without a cutting tool. Because the working environment is unknown, it is impossible to predict the noise that will occur during a deburring operation.
2. Optional Sizes Available, See [Section 7—Serviceable Parts](#).
3. ATI can Supply Burs, See [Section 4.5.1—Bur Selection](#).

9. Terms and Conditions of Sale

The following Terms and Conditions are a supplement to and include a portion of ATI's Standard Terms and Conditions, which are on file at ATI and available upon request.

ATI warrants the compliant tool product will be free from defects in design, materials, and workmanship for a period of one (1) year from the date of shipment and only when used in compliance with the manufacturer's specified normal operating conditions. This warranty does not extend to tool components subject to wear and tear under normal usage; including but not limited to those components that require replacement at standard service intervals. The warranty period for repairs made under a RMA shall be for the duration of the original warranty, or ninety (90) days from the date of repaired product shipment, whichever is longer. This warranty is void if the unit is not used in accordance with guidelines that are presented in this document. ATI will have no liability under this warranty unless: (a) ATI is given written notice of the claimed defect and a description thereof within thirty (30) days after Purchaser discovers the defect and in any event not later than the last day of the warranty period; and (b) the defective item is received by ATI not later ten (10) days after the last day of the warranty period. ATI's entire liability and Purchaser's sole remedy under this warranty is limited to repair or replacement, at ATI's election, of the defective part or item or, at ATI's election, refund of the price paid for the item. The foregoing warranty does not apply to any defect or failure resulting from improper installation, operation, maintenance or repair by anyone other than ATI.

ATI will in no event be liable for incidental, consequential or special damages of any kind, even if ATI has been advised of the possibility of such damages. ATI's aggregate liability will in no event exceed the amount paid by purchaser for the item which is the subject of claim or dispute. ATI will have no liability of any kind for failure of any equipment or other items not supplied by ATI.

No action against ATI, regardless of form, arising out of or in any way connected with products or services supplied hereunder may be brought more than one (1) year after the cause of action occurred.

No representation or agreement varying or extending the warranty and limitation of remedy provisions contained herein is authorized by ATI, and may not be relied upon as having been authorized by ATI, unless in writing and signed by an executive officer of ATI.

Unless otherwise agreed in writing by ATI, all designs, drawings, data, inventions, software and other technology made or developed by ATI in the course of providing products and services hereunder, and all rights therein under any patent, copyright or other law protecting intellectual property, shall be and remain ATI's property. The sale of products or services hereunder does not convey any express or implied license under any patent, copyright or other intellectual property right owned or controlled by ATI, whether relating to the products sold or any other matter, except for the license expressly granted below.

In the course of supplying products and services hereunder, ATI may provide or disclose to Purchaser confidential and proprietary information of ATI relating to the design, operation or other aspects of ATI's products. As between ATI and Purchaser, ownership of such information, including without limitation any computer software provided to Purchaser by ATI, shall remain in ATI and such information is licensed to Purchaser only for Purchaser's use in operating the products supplied by ATI hereunder in Purchaser's internal business operations.

Without ATI's prior written permission, Purchaser will not use such information for any other purpose or provide or otherwise make such information available to any third party. Purchaser agrees to take all reasonable precautions to prevent any unauthorized use or disclosure of such information.

Purchaser will not be liable hereunder with respect to disclosure or use of information which: (a) is in the public domain when received from ATI; (b) is thereafter published or otherwise enters the public domain through no fault of Purchaser; (c) is in Purchaser's possession prior to receipt from ATI; (d) is lawfully obtained by Purchaser from a third party entitled to disclose it; or (f) is required to be disclosed by judicial order or other governmental authority, provided that, with respect to such required disclosures, Purchaser gives ATI prior notice thereof and uses all legally available means to maintain the confidentiality of such information

9.1 Motor Life and Service Interval Statement

The air motors that are used in ATI deburring/finishing tools are subject to wear and have a finite life. Motors that fail, during the warranty period, will be repaired or replaced by ATI as long as there is no evidence of abuse or neglect and that the normal operating practices outlined in this manual have been observed.

Components such as motor vanes, bearings, any gear reduction components, and collet nuts/chucks are considered consumable and are not covered by warranty. The customer should expect to service or replace these items at designated service intervals. For any part that is not detailed in this manual, contact ATI for part numbers and pricing.

Premature bearing failure can occur from exposing the RCT-151 to coolants and water or impacts from collisions. Other failure modes that are outlined in the manual and relate to improper machining practices and deburring media selection.

9.1.1 Turbine Motor Products (RCT models)

Turbine motors are not serviceable at this time. The expected life of a turbine motor in normal operation is entirely application dependent based on a multitude of factors. To maximize the life of turbine motor products, the customer should follow closely the normal operation guide in the product manual. The supplied air must be totally lube free and filtered to remove particulates and moisture. Exposing the turbine motors to oil in the air supply results in premature failure. Premature bearing failure can occur from exposing the RCT-151 to coolants and water or impacts from collisions. Other failure modes are outlined in the manual and relate to improper machining practices and deburring media selection.