

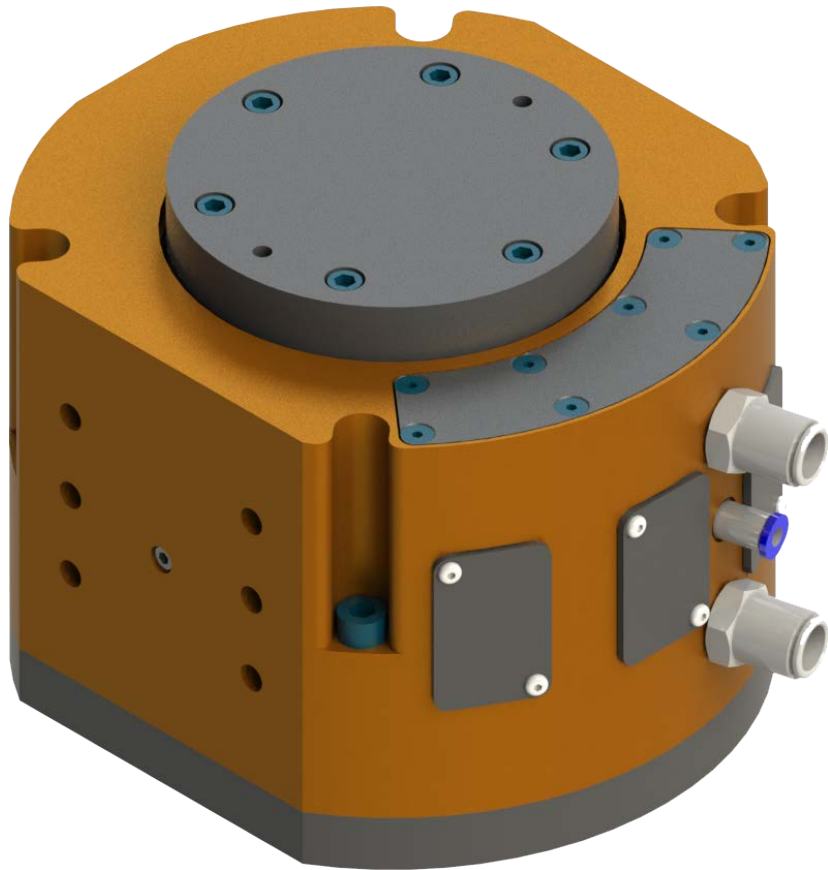

ATI Passive Compliant Force Control

(Models 9150-PCFC-12)

Product Manual



Document #: 9610-50-1036

Engineered Products for Robotic Productivity

Pinnacle Park • 1031 Goodworth Drive • Apex, NC 27539 USA • Tel: +1 919-772-0115 • Fax: +1 919-772-8259 • www.ati-ia.com

Foreword



CAUTION: This manual describes the function, application, and safety considerations of this product. This manual must be read and understood before any attempt is made to install or operate the product, otherwise damage to the product or unsafe conditions may occur.

Information contained in this document is the property of ATI Industrial Automation, Inc (ATI) and shall not be reproduced in whole or in part without prior written approval of ATI. The information herein is subject to change without notice. This manual is periodically revised to reflect and incorporate changes made to the product.

The information contained herein is confidential and reserved exclusively for the customers and authorized agents of ATI Industrial Automation and may not be divulged to any third party without prior written consent from ATI. No warranty including implied warranties is made with regard to accuracy of this document or fitness of this device for a particular application. ATI Industrial Automation shall not be liable for any errors contained in this document or for any incidental or consequential damages caused thereby. ATI Industrial Automation also reserves the right to make changes to this manual at any time without prior notice.

ATI assumes no responsibility for any errors or omissions in this document.

Copyright © (2023) by ATI Industrial Automation. All rights reserved.

How to reach us:

Sale, Service and Information about ATI products:

ATI Industrial Automation

1031 Goodworth Drive
Apex, NC 27539 USA
www.ati-ia.com
Tel: +1 919-772-0115
Fax: +1 919-772-8259

Application Engineering

Tel: +1 919-772-0115
Fax: +1 919-772-8259
E-mail: ATI-MRapplications@novanta.com

24/7 Support: +1 855 ATI-IA 00 (+1 855-284-4200)

Table of Contents

Glossary	5
1. Safety	6
1.1 Explanation of Notifications	6
1.2 General Safety Guidelines	6
1.3 Safety Precautions	6
1.4 PCFC Safe Working Environment	6
2. Product Overview	7
2.1 Features and Benefits of the PCFC	7
2.2 Technical Description	8
2.2.1 Environmental Limitations	8
2.2.1.1 Operation	8
2.2.1.2 Storage	8
2.3 Compliance Unit Performance	9
2.4 Part Numbering Guide	10
3. Installation	11
3.1 Protection During Transportation	11
3.2 Inspection of Condition When Delivered	11
3.3 Unpacking and Handling	11
3.4 Storage and Preventive Maintenance During Storage	11
3.5 Axial Mount Installation	12
3.6 Side Mount Installation	13
3.7 Customer Tooling Installation	14
3.8 Pneumatic Connections	14
3.9 Electrical Connections	16
3.10 Mating Cable	16
4. Operation	17
4.1 Safety Precautions	17
4.2 Minimum Requirements for Operation	18
4.2.1 Air Quality	18
4.2.2 No Lubrication	18
4.2.3 Program the Device to Incorporate 50% Compliance Travel	18
4.3 Normal Operation LED Behavior	19
4.3.1 Gravity Compensation	20
4.3.1.1 Gravity Compensation Procedure	21
4.4 RS485 Serial Console	22
4.5 Set/Cal Commands	24

- 4.6 Filter Parameters 25
- 5. Maintenance..... 26
 - 5.1 Routine Operational Maintenance 26
 - 5.2 Utilities 26
- 6. Troubleshooting 27
- 7. Parts and Accessories 27
 - 7.1 Accessories and Tools 27
- 8. Specifications 27
- 9. Drawings 28
- 10. Terms and Conditions of Sale..... 28

Glossary

Term	Definition
Air Filter	Device for removing contamination from air supply lines. Typically refers to removal of particulates.
Coalescing Filter	Device that removes liquid aerosols from the supply air lines.
Compliance	The ability of the device to passively move in response to protrusions on or deviations of the work piece.
Interface Plate	Adapter plate for attaching the tool to robots or work surfaces.
PCFC	Passive Compliant Force Control - A stand-alone, passive compliance device to be used with an end-effector.
Qty	Quantity
Regulator	Device used to set and control the supplied air pressure to lower acceptable levels.
Solenoid Valve	Electrically controlled device for switching air supplies on and off.

1. Safety

The safety section describes general safety guidelines to be followed with this product, explanations of the notifications found in this manual, and safety precautions that apply to the product. Product specific notifications are imbedded within the sections of this manual (where they apply).

1.1 Explanation of Notifications

These notifications are used in all of ATI manuals and are not specific to this product. The user should heed all notifications from the robot manufacturer and/or the manufacturers of other components used in the installation.



DANGER: Notification of information or instructions that if not followed will result in death or serious injury. The notification provides information about the nature of the hazardous situation, the consequences of not avoiding the hazard, and the method for avoiding the situation.



WARNING: Notification of information or instructions that if not followed could result in death or serious injury. The notification provides information about the nature of the hazardous situation, the consequences of not avoiding the hazard, and the method for avoiding the situation.



CAUTION: Notification of information or instructions that if not followed could result in moderate injury or will cause damage to equipment. The notification provides information about the nature of the hazardous situation, the consequences of not avoiding the hazard, and the method for avoiding the situation.

NOTICE: Notification of specific information or instructions about maintaining, operating, installing, or setting up the product that if not followed could result in damage to equipment. The notification can emphasize, but is not limited to: specific grease types, best operating practices, and maintenance tips.

1.2 General Safety Guidelines

The customer should first read and understand the operating procedures and information described in this manual. Never use the PCFC for any purpose not explicitly described in this manual. Follow installation instructions, electrical connections, and pneumatic connections as described in this manual.

All pneumatic fittings and tubing must be capable of withstanding the repetitive motions of the application without failing. The routing of pneumatic lines must minimize the possibility of stress/strain, kinking, rupture, etc. Failure of critical pneumatic lines to function properly may result in equipment damage.

1.3 Safety Precautions



CAUTION: Only use ATI's original serviceable parts. Use of serviceable parts not supplied by ATI can damage equipment and void the warranty. Always use original ATI serviceable parts.

1.4 PCFC Safe Working Environment

As described in previous sections, the PCFC should only be used in an automated cell/chamber.

The work cell must be secured with barriers to prevent people from entering the cell during operation. The barrier should have a lockable door for only authorized personnel to access the area. Part or all of the barrier should be made of polycarbonate so that people can watch the manufacturing process.

Before entering a cell during system or tool maintenance, ensure the PCFC and equipment are fully stopped. Never be in the cell as the device is running, during installation or while testing.

Be aware of moving parts. Use eye-protection while working around the device.

2. Product Overview

ATI's PCFC device is a robust, stand-alone, passive compliant device to be used with an end-effector.

Figure 2.1—Product Overview

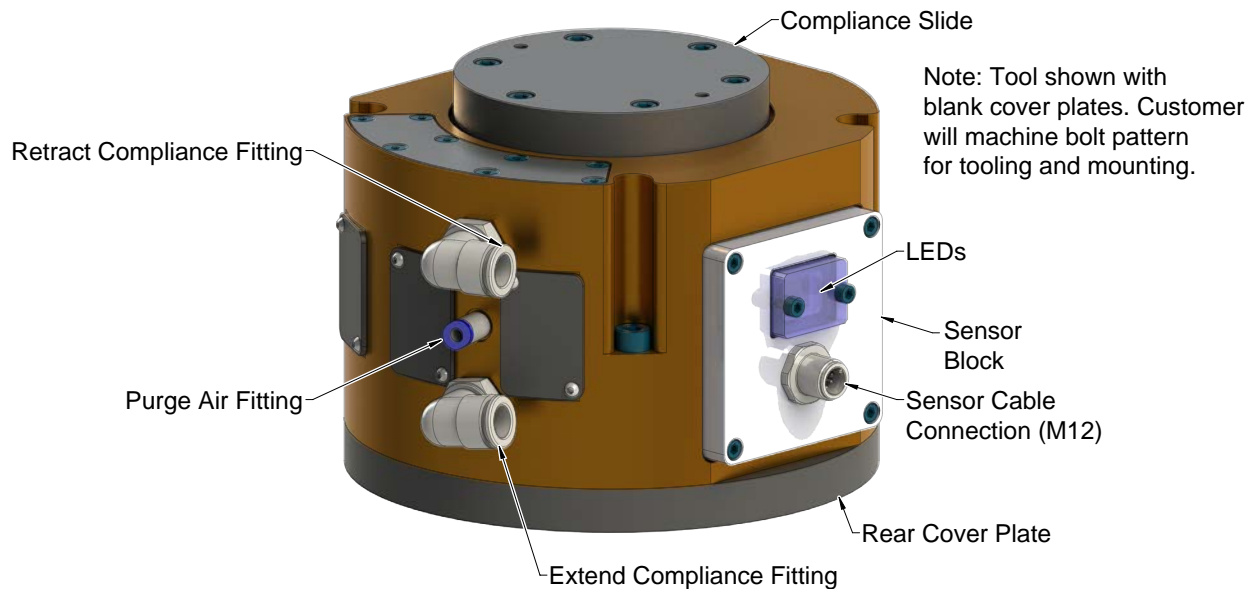

2.1 Features and Benefits of the PCFC

- Floating axial compliance
Remotely-adjusted air pressure controls and maintains the constant axial force on the device. The axially-compliant motion of the device allows the customer's tool to compensate for deviations in the part profile along the robot path and keep a constant contact force with the workpiece.
- Mounting options
The PCFC has a rear cover plate that can be machined for axially mounting the housing and a flat on the side of the housing for side mounting.
- Easy programming of the robot
The axial motion of the PCFC allows fast and simple programming of the robot. This movement also compensates for changes in part tolerances, part misalignment, and robot path variation.
- Gravity Compensation
This feature allows the tool to automatically adjust the compliance force as the tool's orientation changes with gravity.

2.2 Technical Description

A technical overview of the product is provided in the following tables and graphs. For additional technical specifications, refer to [Section 8—Specifications](#).

2.2.1 Environmental Limitations

2.2.1.1 Operation

Table 2.1—Operation	
Installation position	Mounted to machining center by means various, customer-supplied end-effector.
Temperature range	5° C – 35° C 41° F – 95° F
Utilities	The device requires: <ul style="list-style-type: none"> • Clean, dry, filtered, and non-lubricated air (refer to Section 4.2.2—No Lubrication). • A coalescing filter and filter elements that are rated 5 micron or better. • The axial force/compliance air must be supplied up to 4.1 bar (60 PSI) maximum from a regulated source

2.2.1.2 Storage

Table 2.2—Storage	
Temperature range	0° C – 45° C 32° F – 113° F
Conditions	When not in use, the device should be stored in its crate that is kept in a dry area. Consult Section 3.4—Storage and Preventive Maintenance During Storage of this manual.

2.3 Compliance Unit Performance

The force created by the compliance mechanism varies linearly with air pressure as shown in [Figure 2.2](#). The force characteristics shown are for horizontal, rigidly-mounted installations. This does not account for friction or the weight of the carriage and attached tooling. Measurements may vary from one product to another and should only be treated as nominal. The effect of friction will vary based on the application, and a minimum compliance force is required to overcome the friction and allow the compliance mechanism to move properly. This minimum force is typically 2-4 lbf, but it may be higher or lower based on a variety of factors.

Figure 2.2—Compliance Force

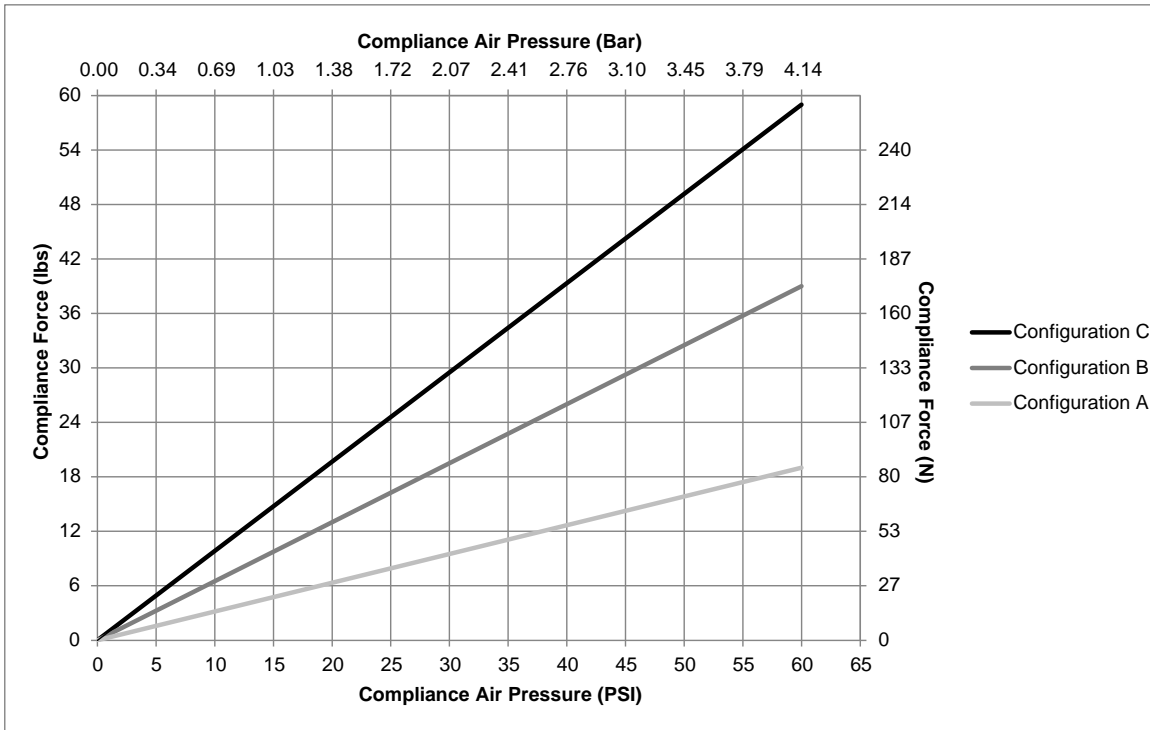

If using the Gravity Compensation functionality of the PCFC, refer to [Section 4.3.1—Gravity Compensation](#) for instructions on how to select the correct pressure for your desired compliance force. If not using Gravity Compensation, refer to [Figure 2.2](#) and factor in the weight of the attached tooling plus an additional 2.2 pounds for the carriage inside the PCFC. If the PCFC is pointed upward, this weight will reduce the net compliance force, requiring a higher operating pressure to achieve the desired compliance force. If the PCFC is pointed downward, it will increase the net compliance force, requiring a lower operating pressure (or a higher pressure applied to the retract compliance fitting) to achieve the desired compliance force.

2.4 Part Numbering Guide

Figure 2.3—Part Numbering Guide

PCFC-12 Part Number Guide

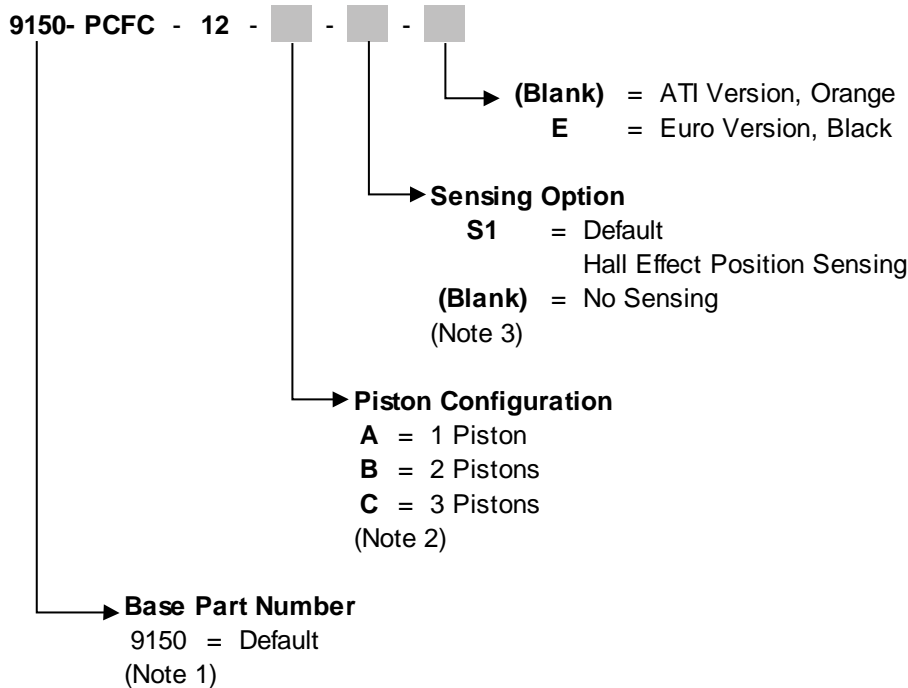

Notes:

1. Although this is a 9150 (Material Removal) base part number, the PCFC acts like a compensator. It is a double acting, single axis compensator product that is also featured under the ATI Compensator product line.
2. Compliance force range is dictated by the piston selection.
 - A = 19 lbf (84.5 N)
 - B = 38.6 lbf (171.7 N)
 - C = 59.1 lbf (242.9 N)
3. Position Sensing Option (-S1) is the default product configuration. Sensing outputs relative position along the 12mm stroke path via (3) LED's.

Filename: 9645-50-1001, Rev 03

3. Installation

The compliance housing incorporates a rear mounting pattern to which an interface plate can be installed (Refer to [Section 3.5—Axial Mount Installation.](#)) An interface plate for side mounting to fixed surface is available (Refer to [Section 3.6—Side Mount Installation.](#))

The device must be rigidly mounted prior to use. Under no circumstances should the device be used for manual/hand operations. Once securely mounted, the device shall be supplied with clean, non-lubricated air filtered (5) micron or better. The use of a coalescing filter is recommended to remove trace moisture from the air supply. Air line fittings supplying the PCFC should be installed with care using a minimum of tape or liquid sealant. To prevent contaminant damage to the device, all air lines should be blown down to remove debris prior to connection of the PCFC.



CAUTION: Thread locker applied to fasteners must not be used more than once. Fasteners might become loose and cause equipment damage. Always apply new thread locker when reusing fasteners.

3.1 Protection During Transportation

The PCFC arrives in packaging that secures and protects the device during transportation. Always use this packaging when transporting the PCFC in order to minimize the risk of damage.

3.2 Inspection of Condition When Delivered

Upon receipt, the following should be verified:

- Delivery in accordance with freight documents
- Packaging is in good condition

If there is damage to any of the packaging, or if any of the goods have been exposed to abnormal handling, unpack those parts for a closer inspection. Contact ATI for assistance.

3.3 Unpacking and Handling

Always place the PCFC inside the accompanying packaging, while transportation, storing, and handling.

3.4 Storage and Preventive Maintenance During Storage

For short-term storage, the device should be stored in its accompanying packaging and in a dry place.

For long-term storage, the PCFC should be thoroughly cleaned of any dust or debris. Never disassemble the units. Place the device inside a sealed, plastic bag and place the bagged device inside the crate.

3.5 Axial Mount Installation

A blank rear cover plate is provided for axial mounting of the PCFC housing. This plate must be modified by the system integrator or by the owner/user of the PCFC. When machining a bolt pattern into the plate, allow for the heads of the fasteners to be countersunk-flush or below-flush with the surface of rear cover plate which mounts to PCFC body.

Figure 3.1—Axial Mount Installation

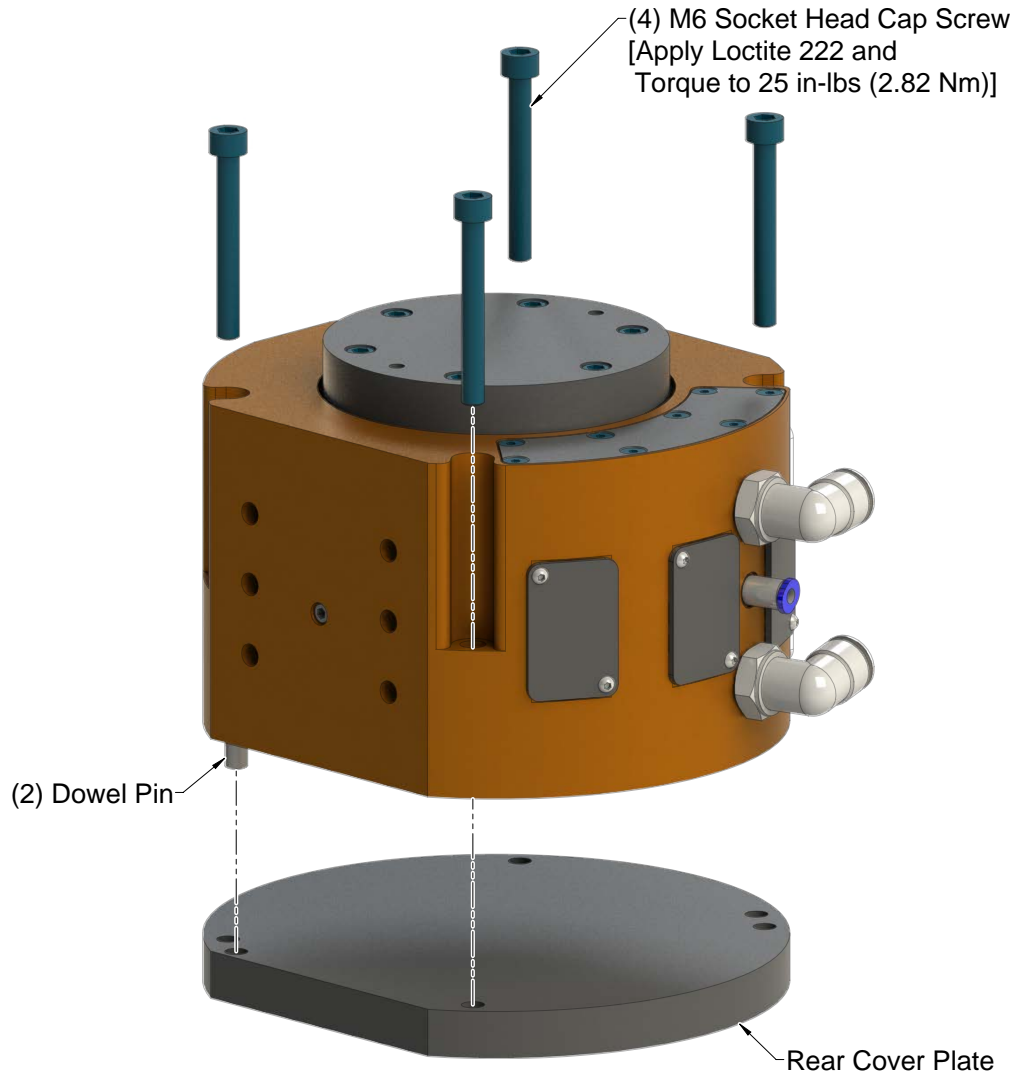

NOTICE: Do not modify existing mounting holes between the rear cover plate and PCFC body.

3.6 Side Mount Installation

The side mount pattern of the PCFC consists of (2) dowel pin holes and (4) threaded holes as shown in [Figure 3.2](#). With this configuration, the PCFC can be installed on a still surface, and the robot carries a part to the end-effector attached to the PCFC.

Figure 3.2—Side Mount Installation

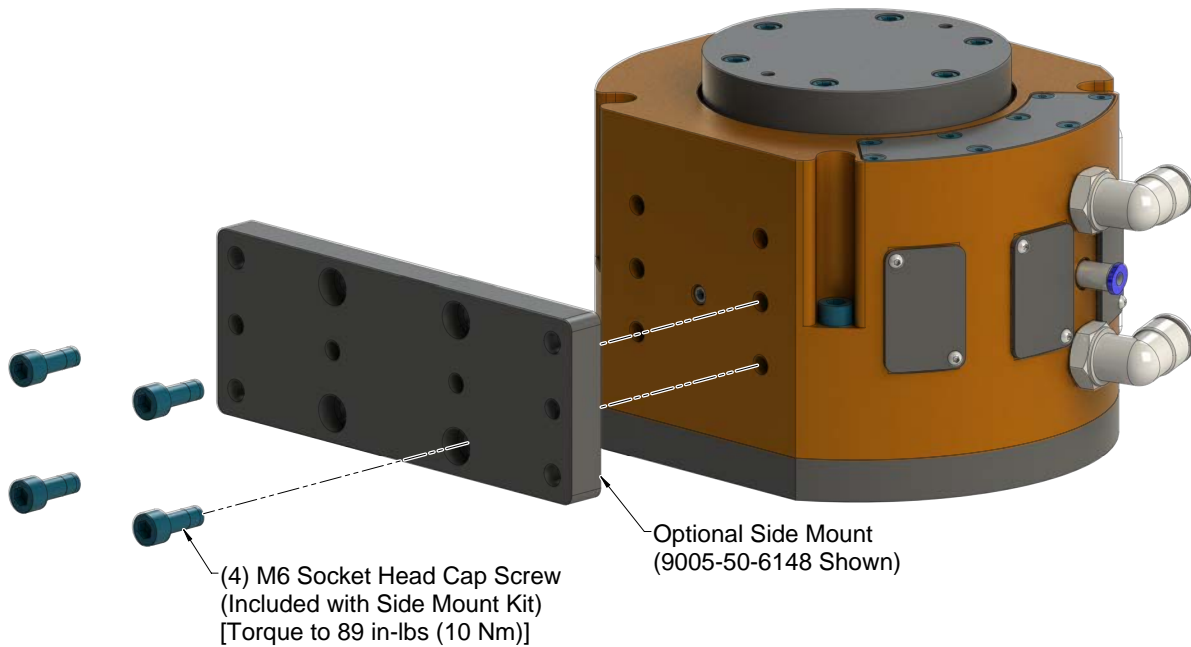

3.7 Customer Tooling Installation

The system integrator or the owner/user must machine the inner slide cover plate to interface with customer tooling.

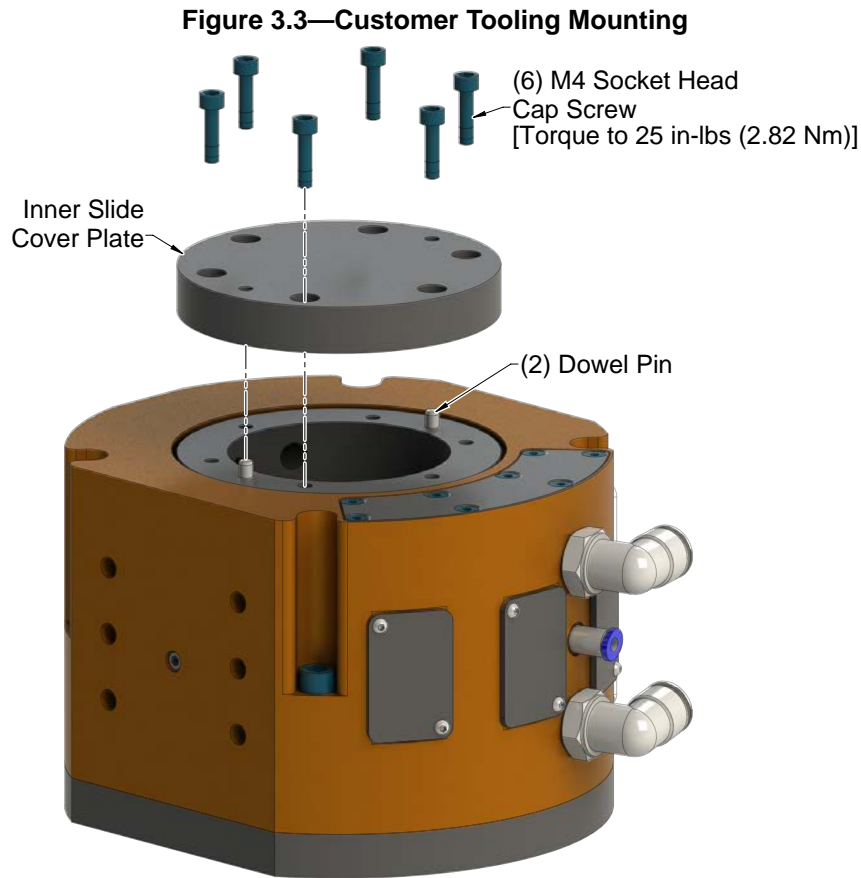

NOTICE: Do not modify existing mounting holes between the cover plate and slide.

3.8 Pneumatic Connections

Connect the PCFC as shown on the pneumatic diagram (9630-50-PCFC-PNEUMATIC) which is available on the ATI website.



WARNING: All pneumatic fittings and tubing must be capable of withstanding the repetitive motions of the application without failing. The routing of pneumatic lines must minimize the possibility of over stressing, pullout, or kinking the lines. Failure to do so can cause some critical pneumatic lines not to function properly and may result in damage to the equipment.

NOTICE: It is recommended that the customer use a coalescing filter and filter elements rated 5 micron or better to remove trace moisture. Water damage of the air device or damage associated with debris in the air lines is not covered under warranty.

Depending on whether the PCFC is changing orientation during operation or held still, the required pneumatic components vary.

- a. Regardless of orientation, one regulator is needed for the Purge Air Fitting. Set this regulator to 30 PSI (2.1 bar) to prevent ingress of dust or other particulates.
- b. If mounting the PCFC on a robot or other moving machinery which will change the orientation of the PCFC, then two electronically controlled regulators are required.

ATI recommends the use of our regulator kit (ATI Part # 9005-50-6164) which was designed for this purpose. If the customer is supplying their own regulators, they must meet the following criteria:

1. The regulators must be controlled by an analog signal (either 0...5VDC, 0...10VDC, or 4...20 mA). By default, the PCFC is set to the 0...5VDC output setting. If using a regulator which requires a 0...10VDC or 4...20mA control signal, refer to [Section 4.4—RS485 Serial Console](#) to change this setting.
2. The regulators must supply a pressure range of approximately 1-60 PSI (0.1-4.1 bar). A reduced pressure range will limit and may negatively impact the performance of the PCFC's Gravity Compensation functionality.



WARNING: The regulator range must not exceed 70 PSI (4.8 bar). Over pressurization may risk damaging the PCFC.

3. The regulators must be self-relieving.

One of the electronic regulators will be controlled by the PCFC, via the VO/IO_REG+ signal (See [Table 3.2](#)). That regulator must connect to the Retract Compliance Fitting. The second electronic regulator should be controlled by the robot or PLC, and it will connect to the Forward Compliance Fitting. See [Section 4.3.1—Gravity Compensation](#) for instructions on how to determine the correct pressure setting.

- c. If mounting the PCFC in a rigid manner or if the PCFC will be kept in a single orientation during the full process, only a single self-relieving regulator is required for the compliance mechanism. It may be manually or electronically controlled, depending on the customer's preference and the needs of the specific application. If the PCFC is mounted upright or horizontally, connect the regulator to the forward compliance fitting to supply a positive process force. If the PCFC is holding the tool in a hanging position, connect the regulator to either the forward compliance fitting or the retract compliance fitting in order to either increase or decrease the process force which will include the weight of the tool. This regulator may be set between 0-60 PSI (0-4.1 bar). Connect some flexible tube to the other compliance fitting and route it away from debris will be generated to prevent ingress that could damage the compliance mechanism. Do not use a plug or restrict air from flowing to that connection.

Table 3.1—Pneumatic Connections		
Function	Connection Type	Pressure
Compliance (Axial) Force Inlet	(2) 3/8 (10 mm) Tube	Up to 60 psi (4.1 bar) maximum
Purge Air	5/32 (4 mm) Tube	30 psi (2 bar)

The device must be plumbed using flexible tubing.

When testing for the proper contact force, start with a very low force and increase slowly until the desired process result is achieved. Typical applications will need a minimum of 2-4 pounds of compliance force to overcome the internal friction of the compliance mechanism. This may vary higher or lower based on a variety of factors.

3.9 Electrical Connections

Refer to the following for electrical connection pinouts. Cable shielding is required. A cable is available for purchase separately from the PCFC part number. Refer to [Section 3.10—Mating Cable](#).

Figure 3.4—M12 8-Pin Connector Wiring (Face View Shown)

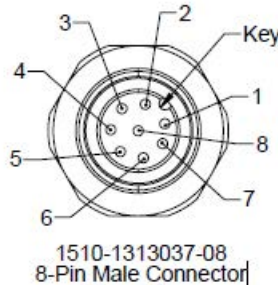

Table 3.2—M12 8-Pin Connector Wiring

Pin	Signal name	Description	Voltage/Current
1	V+	Power (Positive)	24VDC+/-20%
2	V-	Power (GND)	0V
3	VO-/IO-	Analog Output Reference	0V
4	Cal+	Initiate Calibration Input	Pulse (24VDC+/-20%)
5	VO/IO_REG+	Analog output (Regulator)	0-5V, 0-10V, 4-20mA ¹
6	VO/IO_POS+	Analog output (Position)	0-5V, 0-10V, 4-20mA ¹
7	RS485+	Serial Data	NA
8	RS485-	Serial Data	NA

Note:
 1. Default value for a new unit is 0-5V.

3.10 Mating Cable

ATI offers a shielded mating cable to interface to the M12 Connector found on the unit. Refer to the following part number when ordering: 9150-C-0521108-U-00-10.

4. Operation

These operating instructions are intended to help system integrators program, start up, and complete a robotic cell containing the device. The system integrator should be familiar with the task in general and should have extensive knowledge relating to robots and automation incorporating robots.

4.1 Safety Precautions



DANGER: Never use the PCFC for purposes other than automated processes. Never use the PCFC as a hand-held machine.



WARNING: All personnel, who are involved in the operation of the PCFC product, should have a thorough understanding of the operating procedures. Failure to follow these procedures or neglecting safety precautions can create hazardous situations that may injure personnel or damage the deburring installation and the PCFC product.



WARNING: Never operate the ATI product without wearing eye protection. Flying debris can cause injury. Always use eye protection while working in the proximity of the device.



CAUTION: Do not use replacement parts other than original ATI replacement parts. Use of replacement parts not supplied by ATI can damage equipment and void the warranty. Always use original ATI replacement parts.

4.2 Minimum Requirements for Operation

The following sections describes the minimum requirements for operating the PCFC.

4.2.1 Air Quality

The air supply should be clean, dry, filtered, and non-lubricated. A coalescing filter that has elements rated for 5 micron or better is required.

Air quality can affect tool performance substantially. Particulates can block airflow or impede motion.

4.2.2 No Lubrication

The compliance device cannot have any oil in the air supply. Oil can clog compliance device and limit compliance range.

4.2.3 Program the Device to Incorporate 50% Compliance Travel

Program the device to have compliance at 50% travel when on the nominal path.

As the part's edge deviates from the perfect path, the device can use compliance to follow along high and low spots without losing contact or hitting the positive stop and gouging.

Do not bottom out the compliance and hit the positive stop.

Repeated impacts on the positive stop can damage the compliance mechanism.

Figure 4.1—50% Travel

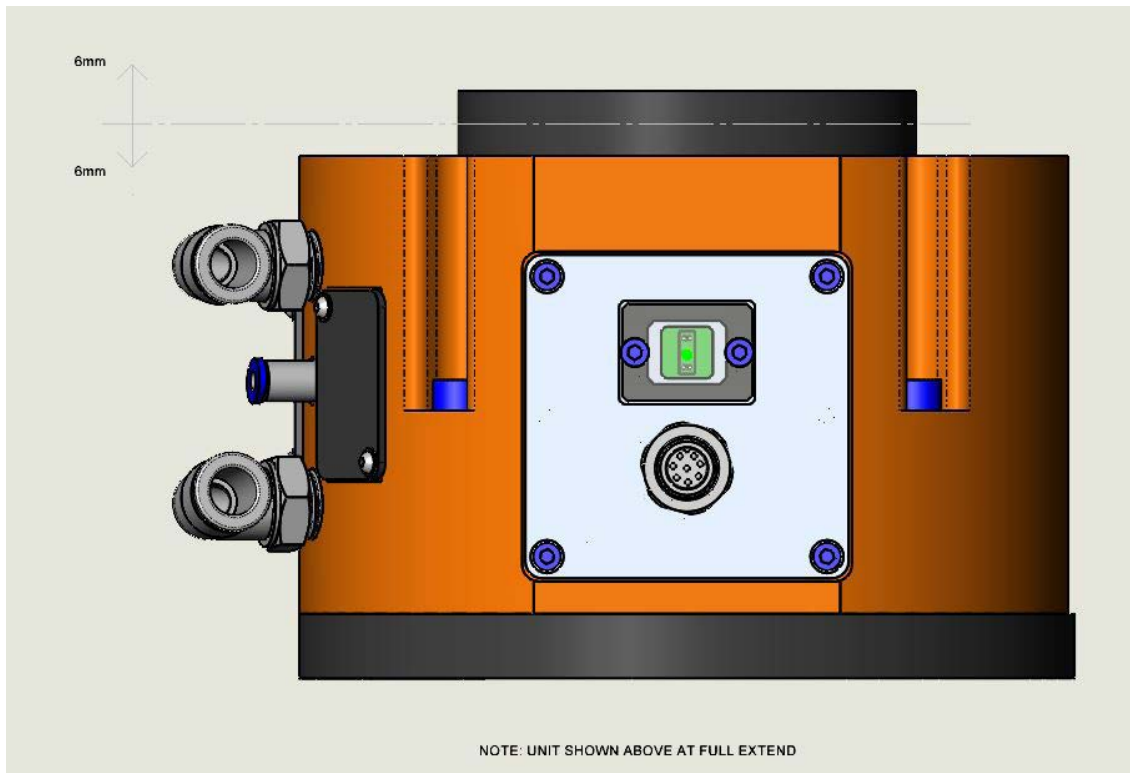

4.3 Normal Operation LED Behavior

Figure 4.2—LEDs

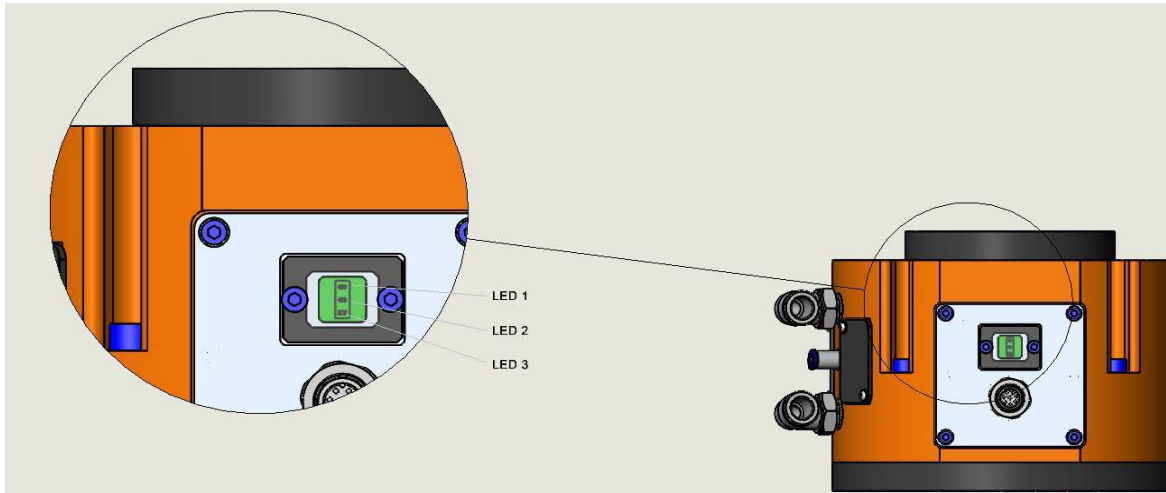

	Full Extend (> 95% Extension)	Start of Travel (Extension > 70% and <= 95%)	Safe Travel Zone (Extension >= 30% and <= 70%)	End of Travel (Extension >= 5% and < 30%)	Robot Crash (< 5% Extension)
LED 1					
LED 2					
LED 3					

4.3.1 Gravity Compensation

The PCFC sensor kit supports gravity compensation. This feature allows the tool to automatically adjust the compliance force as the tool's orientation changes with respect to gravity. A sensor built into the tool tracks the tool's movements and notes when the tool rotates about X or Y. As this change occurs, a signal is sent to a programmable regulator to adjust the air pressure being sent to the retract air-port. This increase or decrease in air pressure allows the tool to compensate for the changing forces applied to the workpiece by the weight of the tool. It is important to note that if a user is planning to use gravity compensation, the weight of the tooling cannot exceed 50% of the PCFC's maximum compliance force. This is because when the PCFC is pointed straight down, the force of the retract pressure must equal two times the weight of the tooling in order to properly bias out the weight over the entire range of motion.

Without gravity compensation, it is possible to maintain consistent force between a workpiece and tool through the various tool orientations necessary in complex motions, but it can be very difficult and time consuming. In standard operation, the force applied would be subject to the orientation of the tool. When the workpiece is "above" the tool, the pistons push the tool "up" toward the workpiece while gravity counteracts the pistons and pulls the tool "away" from the workpiece. However, when the tool rotates and the workpiece is now "below" the tool, the pistons still push with the same amount of force toward the workpiece, but now that force combines with the effect of gravity which pulls the tool "toward" the workpiece, creating a large increase on force applied to the workpiece. This range in force (compliance force +/- weight of tool) can be severe and as varied as the tools that are fixed to the PCFC. Varying force can lead to inconsistent results and poor process performance.

4.3.1.1 Gravity Compensation Procedure

1. Position the PCFC oriented tool side straight down with all tooling attached and connections made. Do not move the PCFC until the entire procedure is finished.

NOTICE: The regulator that the PCFC is controlling should be connected to the retract pressure.

2. Set the regulator connected to forward pressure (which is not controlled by the PCFC) to zero.
3. Send the calibration command electronically. This can be done through either the serial command "StartCal" or the digital input line on Pin 4 (see [Table 3.2](#)).
4. Wait for the PCFC to finish the calibration routine. The PCFC will fully retract and fully extend the compliance mechanism once, and the LEDs will change their state during this routine. When the routine is finished, the default LED behavior is resumed.
5. Read the pressure value on the regulator controlled by the PCFC. Call this P1. P1 should be less than 60 psi. If not, ensure the weight of the tooling is less than 50% of the PCFC's maximum compliance force. If using serial commands, check that the "CalWeight" value is less than 50 in the serial console. If CalWeight reads as 50 or higher, the tooling is too heavy to accomplish gravity compensation with the current configuration and ATI's MR Applications should be contacted for assistance (refer to page 2).
6. The following equation can be used as a starting point to determine what value the forward pressure to be set to: $P2 = \frac{1}{2} \cdot P1 + \frac{1}{s} \cdot F$, where F is the desired force that the PCFC will apply to the workpiece and S is the surface area of the pistons, which can be found for each configuration in the following table:

Piston Configuration	S Value (in ²)
A – 1 Piston	0.32
B – 2 Pistons	0.64
C – 3 Pistons	0.96

7. Gravity compensation is complete.

4.4 RS485 Serial Console

Table 4.2—PCFC Default Values	
Parameter Name	Default Value
paramWrites	0
filTcAccl	8
filTc	3
minPos	0
maxPos	3300
Location	Insert your location here
serNum	Serial number
hwProdCode	HW Product Code
hwRev	0
Baud	115200
Msg	0
productName	ATI Compliance Regulator
posOutputRange	5
regOutputRange	5
CalWeight	0
DelayRamp	10
DelayMaxMin	3000

The following serial console commands are available to use with a program like PuTTY (available online) with a default baud rate of 115200.

Table 4.3—Serial Console Commands		
Command	Operand(s)	Description
?		Print help text
H		
Help		
Man		
SysVer		Print firmware version
Set / Cal		Read all parameters
	[parameter name]	Read all parameters that match input parameter name
	[parameter name] [value]	Write a new value to the parameter matching input parameter name
SaveAll		Save all changes to parameters
StartCal		Start gravity compensation calibration process
	stop	Cancels any ongoing gravity compensation calibration process
Stream		Stream data over console interface. A single operand can be used or multiple operands, for example: HDBXYZIJKLMNTP%OR
	X	Raw accelerometer X axis
	Y	Raw accelerometer Y axis
	Z	Raw accelerometer Z axis
	I	Filtered accelerometer X axis
	J	Filtered accelerometer Y axis
	K	Filtered accelerometer Z axis
	L	Normalized accelerometer X axis
	M	Normalized accelerometer Y axis
	N	Normalized accelerometer Z axis
	R	DAC position
	O	DAC regulator
	%	Position
	P	Raw hall effect sensor
	F	Filtered hall effect sensor
	T	Temperature
	#	Line counter
	S	Checksum
	H	Hexadecimal
	D	Decimal
B	Binary	
>	Compressed	
<	Formatted	
Flow		Display current data during each step of main signal flow
Status		Display status report
LEDTest		Run startup LED test
Reset		Reset MCU (Microcontroller Unit)

4.5 Set/Cal Commands

The following fields can be called after entering Set or Cal to read the current value of a field or write a new value to writable fields.

Table 4.4—Set/Cal Commands					
Field	Long Name	Example Contents	Type	Description	Read/Write
paramWrites	Parameter Writes	0	Uint16	Number of times parameters were saved to NVM	Read only
filTcAccl	Accelerometer filter time constant	6	Uint16	Accelerometer IIR filter shift constant	Read/Write
filTc	Hall effect sensor filter time constant	3 (Refer to Table 4.5)	Uint16	Hall effect sensor IIR filter shift constant	Read/Write
minPos	Minimum position	0	Uint16	Value of the hall effect sensor at minimum position	Read only
maxPos	Maximum position	3300 mV	Uint16	Value of hall effect sensor at maximum position	Read only
Location	Location	customer location	String (40)	Intended to add comment about physical location	Read/Write
serNum	Serial Number	Serial Number	String (100)	Product serial number	Read only
hwProdCode	Hardware product code	HW Product Code	String (20)	Hardware product code	Read only
hwRev	Hardware revision	0	Uint16	Hardware revision	Read only
baud	Serial baud rate	115200	Uint32	Serial console baud rate	Read/Write
Msg	Message	0	Uint8	1=Print all messages 0=Print only prompted messages	Read/Write
productName	Product name	ATI Compliance Regulator	String (32)	Product name	Read only
posOutputRange	Position Output Range	5	Uint16	Analog output ranges for position 5=0-5V (default) 10=0-10V 20=4-20mA	Read/Write
regOutputRange	Regulator Output Range	5	Uint16	Analog output ranges for regulator 5=0-5V (default) 10=0-10V 20=4-20mA	Read/Write

Table 4.4—Set/Cal Commands					
Field	Long Name	Example Contents	Type	Description	Read/Write
CalWeight	Calibration weight	25		Gravity compensation gain calculated from calibration process (%)	Read/Write
DelayRamp	Calibration ramp delay	10	Uint16	Time to delay between 1000 steps in calibration process (ms)	Read/Write
DelayMaxMin	Calibration max/min settling time delay	3000	Uint16	Settling time delay to wait before measuring minimum and maximum positions during calibration process (ms)	Read/Write

4.6 Filter Parameters

Table 4.5—filTc Parameters	
Parameter value	Low-pass frequency cutoff
0	No filter
1	119.7 Hz
2	46.6 Hz
3	21.7 Hz
4	10.4 Hz
5	5.1 Hz
6	2.6 Hz
7	1.2 Hz
8	0.7 Hz-

5. Maintenance

Periodically visually inspect the purge air opening for damage, and use a clean cloth to clean the opening.

5.1 Routine Operational Maintenance

When subjected to normal use, this robust unit will provide hours of operation before service or repair is necessary. When subjected to high shock loading or periods of continuous service without interruption, the unit will require service or repair earlier. While simple in design, there are few user-serviceable parts in the assembly. The user is encouraged to return the unit to ATI for service.



CAUTION: For all service, it is recommended that the air supply be disconnected.

Drain any trapped air pressure in the lines. It is suggested that the air supply be “locked out” to prevent accidental operation of the device. During maintenance operations, refer to [Section 9—Drawings](#).

5.2 Utilities

The air tubing and fittings to the unit should routinely be checked for general condition and replaced as required. The lines must be flexible to allow free motion when the unit is mounted to a moving surface or robot. The air to the device must be filtered, dry, and non-lubricated. The life of the filter elements is dependent on the quality of compressed air at the customer’s facility.

6. Troubleshooting

The following section provides troubleshooting information to help diagnose conditions with the product and service procedures to help resolve these conditions.

Symptom	Cause	Resolution
Unequal compliance	Defective regulator	Replace defective regulator
Compliance slide sticking	Compliance slide contaminated	Clean the compliance slide with compressed air and alcohol.
	No purge air	Check that purge air is supplied
	Low or no air pressure	Check that air is supplied at proper pressure
	Regulator not connected	Check regulator connection
	Load too heavy	Check load is within specification

7. Parts and Accessories

Refer to [Section 9—Drawings](#) for exploded drawings that show the user replaceable components of the PCFC.

7.1 Accessories and Tools

Item No.	Qty	Part Number	Description
1	1	9005-50-6164	Regulator Kit, PCFC-12
2	1	9005-50-6148	Side Mount Kit, PCFC
3	1	9005-50-6084	Port Reduction Plug Kit, PCFC-12
4	1	9005-50-6088	Piston Kit, PCFC-12
5	1	9005-50-6160	Coalescing filter, regulator air prep kit
6	1	9150-C-0521108-U-00-10	M12 Shielded Cable

8. Specifications

Parameter	Rating
Weight total (w/o adapter)	7.8 lbs (3.5 kg)
Compensation (axial)	0.47 in. max. axial (12 mm max. axial)
Pneumatic Connections	Compliance - (2) 3/8 (10 mm) Tube Purge - 5/32 (4 mm) Tube
Baud Rate	115200
I/O	RS485, 0-10V, 4-20mA (+/- 4% accuracy)
	8 pin, M12 Connector
Electrical Rating	24V+/-20%, 125mA, 3W

9. Drawings

To access the PCFC Drawings, use the following links:

- https://www.ati-ia.com/app_content/Documents/9630-50-PCFC-12.auto.pdf
- https://www.ati-ia.com/app_content/Documents/9630-50-PCFC-PNEUMATIC.auto.pdf

10. Terms and Conditions of Sale

ATI warrants the compliant tool product will be free from defects in design, materials and workmanship for a period of one (1) year from the date of shipment and only when used in compliance with manufacturer's specified normal operating conditions. This warranty does not extend to tool components subject to wear and tear under normal usage; including but not limited to those components requiring replacement at standard service intervals.

The warranty period for repairs made under a RMA shall be for the duration of the original warranty, or ninety (90) days from the date of repaired product shipment, whichever is longer. This warranty is void if the unit is not used in accordance with guidelines presented in this document. ATI will have no liability under this warranty unless: (a) ATI is given written notice of the claimed defect and a description thereof within thirty (30) days after Purchaser discovers the defect and in any event not later than the last day of the warranty period; and (b) the defective item is received by ATI not later ten (10) days after the last day of the warranty period. ATI's entire liability and Purchaser's sole remedy under this warranty is limited to repair or replacement, at ATI's election, of the defective part or item or, at ATI's election, refund of the price paid for the item. The foregoing warranty does not apply to any defect or failure resulting from improper installation, operation, maintenance or repair by anyone other than ATI.